

THIS DRAWING IS UNCLASSIFIED
 UNLESS INDICATED OTHERWISE
 ALL RIGHTS RESERVED

REV	DATE	DESCRIPTION	BY	CHK	APP
AA	22	REVISED PER EDD-11-005033	26MHR11	RK	HMR

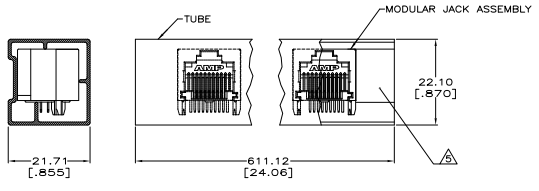

DETAIL A
 TUBE PACKAGING
 SCALE 2:1

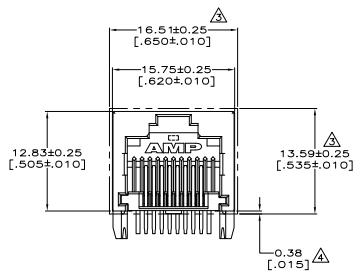
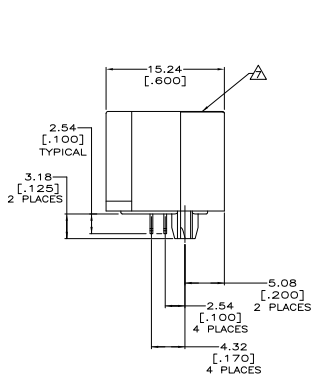
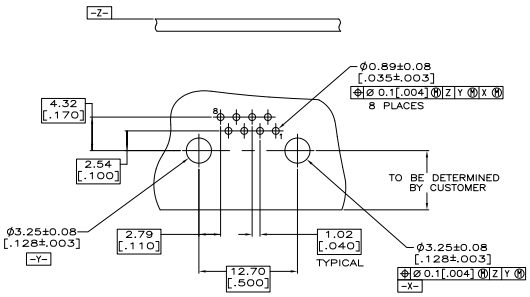

SUGGESTED PRINTED CIRCUIT BOARD LAYOUT
 (COMPONENT SIDE)

- ▲ MATERIAL:
 HOUSING - HIGH TEMPERATURE THERMOPLASTIC, BLACK, UL94V-0; IR REFLOW SOLDERING PROCESS COMPATIBLE.
 TERMINALS - .36[.014] THICK PHOS BRONZE PLATED WITH 3.81µm[.000150] MINIMUM THICK (SEE P/N TABLE) IN SOLDER AREA, 1.27µm[.000050] MINIMUM GOLD IN LOCALIZED PLATE AREA, ENTIRE TERMINAL PLATED WITH 1.27µm[.000050] MINIMUM THICK NICKEL.
- 2. JACK CAVITY CONFORMS TO FCC RULES AND REGULATIONS PART 68, SUBPART F.
- ▲ SUGGESTED PANEL OPENING DIMENSIONS.
- ▲ SUGGESTED CLEARANCE BETWEEN BOTTOM OF CONNECTOR AND BOTTOM PANEL OPENING.
- ▲ PACKAGED 35 PIECES PER TUBE, SEE DETAIL "A".
- ▲ 80 PIECES/TRAY, 10 TRAYS/BOX.
- ▲ MANUFACTURING DATE CODE: INK STAMP, LOCATED APPROX. AS SHOWN:
 FIRST 2 DIGITS = LAST 2 DIGITS OF YEAR.
 NEXT 2 DIGITS = MANUFACTURING WORK WEEK.
 LAST DIGIT = DAY OF WEEK WITH SUNDAY = 1.

FINISH	TERMINAL PLATING	PACKAGING	PART NUMBER
MATTE TIN	▲ TUBE		1-406525-3
MATTE TIN	▲ TRAY, PICK & PLACE COMPATIBLE		1-406525-2
MATTE TIN	TRAY		1-406525-1
BRIGHT TIN-LEAD	▲ TUBE		406525-3
BRIGHT TIN-LEAD	▲ TRAY, PICK & PLACE COMPATIBLE		406525-2
BRIGHT TIN-LEAD	TRAY		406525-1

THIS DRAWING IS A CONTROLLED DOCUMENT.		DR. G. CASSETT	TRFRT	TE Connectivity	
UNLESS OTHERWISE SPECIFIED:	UNLESS OTHERWISE SPECIFIED:	DR. M. CASSETT	TRFRT	TE Connectivity	
DIMENSIONS (IN INCHES)	UNLESS OTHERWISE SPECIFIED:	DR. M. CASSETT	TRFRT	TE Connectivity	
1. DIMENSIONS	1. DIMENSIONS	DR. M. CASSETT	TRFRT	TE Connectivity	
2. DIMENSIONS	2. DIMENSIONS	DR. M. CASSETT	TRFRT	TE Connectivity	
3. DIMENSIONS	3. DIMENSIONS	DR. M. CASSETT	TRFRT	TE Connectivity	
4. DIMENSIONS	4. DIMENSIONS	DR. M. CASSETT	TRFRT	TE Connectivity	
5. DIMENSIONS	5. DIMENSIONS	DR. M. CASSETT	TRFRT	TE Connectivity	
6. DIMENSIONS	6. DIMENSIONS	DR. M. CASSETT	TRFRT	TE Connectivity	
7. DIMENSIONS	7. DIMENSIONS	DR. M. CASSETT	TRFRT	TE Connectivity	
8. DIMENSIONS	8. DIMENSIONS	DR. M. CASSETT	TRFRT	TE Connectivity	
9. DIMENSIONS	9. DIMENSIONS	DR. M. CASSETT	TRFRT	TE Connectivity	
10. DIMENSIONS	10. DIMENSIONS	DR. M. CASSETT	TRFRT	TE Connectivity	
11. DIMENSIONS	11. DIMENSIONS	DR. M. CASSETT	TRFRT	TE Connectivity	
12. DIMENSIONS	12. DIMENSIONS	DR. M. CASSETT	TRFRT	TE Connectivity	
13. DIMENSIONS	13. DIMENSIONS	DR. M. CASSETT	TRFRT	TE Connectivity	
14. DIMENSIONS	14. DIMENSIONS	DR. M. CASSETT	TRFRT	TE Connectivity	
15. DIMENSIONS	15. DIMENSIONS	DR. M. CASSETT	TRFRT	TE Connectivity	
16. DIMENSIONS	16. DIMENSIONS	DR. M. CASSETT	TRFRT	TE Connectivity	
17. DIMENSIONS	17. DIMENSIONS	DR. M. CASSETT	TRFRT	TE Connectivity	
18. DIMENSIONS	18. DIMENSIONS	DR. M. CASSETT	TRFRT	TE Connectivity	
19. DIMENSIONS	19. DIMENSIONS	DR. M. CASSETT	TRFRT	TE Connectivity	
20. DIMENSIONS	20. DIMENSIONS	DR. M. CASSETT	TRFRT	TE Connectivity	
21. DIMENSIONS	21. DIMENSIONS	DR. M. CASSETT	TRFRT	TE Connectivity	
22. DIMENSIONS	22. DIMENSIONS	DR. M. CASSETT	TRFRT	TE Connectivity	
23. DIMENSIONS	23. DIMENSIONS	DR. M. CASSETT	TRFRT	TE Connectivity	
24. DIMENSIONS	24. DIMENSIONS	DR. M. CASSETT	TRFRT	TE Connectivity	
25. DIMENSIONS	25. DIMENSIONS	DR. M. CASSETT	TRFRT	TE Connectivity	
26. DIMENSIONS	26. DIMENSIONS	DR. M. CASSETT	TRFRT	TE Connectivity	
27. DIMENSIONS	27. DIMENSIONS	DR. M. CASSETT	TRFRT	TE Connectivity	
28. DIMENSIONS	28. DIMENSIONS	DR. M. CASSETT	TRFRT	TE Connectivity	
29. DIMENSIONS	29. DIMENSIONS	DR. M. CASSETT	TRFRT	TE Connectivity	
30. DIMENSIONS	30. DIMENSIONS	DR. M. CASSETT	TRFRT	TE Connectivity	
31. DIMENSIONS	31. DIMENSIONS	DR. M. CASSETT	TRFRT	TE Connectivity	
32. DIMENSIONS	32. DIMENSIONS	DR. M. CASSETT	TRFRT	TE Connectivity	
33. DIMENSIONS	33. DIMENSIONS	DR. M. CASSETT	TRFRT	TE Connectivity	
34. DIMENSIONS	34. DIMENSIONS	DR. M. CASSETT	TRFRT	TE Connectivity	
35. DIMENSIONS	35. DIMENSIONS	DR. M. CASSETT	TRFRT	TE Connectivity	
36. DIMENSIONS	36. DIMENSIONS	DR. M. CASSETT	TRFRT	TE Connectivity	
37. DIMENSIONS	37. DIMENSIONS	DR. M. CASSETT	TRFRT	TE Connectivity	
38. DIMENSIONS	38. DIMENSIONS	DR. M. CASSETT	TRFRT	TE Connectivity	
39. DIMENSIONS	39. DIMENSIONS	DR. M. CASSETT	TRFRT	TE Connectivity	
40. DIMENSIONS	40. DIMENSIONS	DR. M. CASSETT	TRFRT	TE Connectivity	
41. DIMENSIONS	41. DIMENSIONS	DR. M. CASSETT	TRFRT	TE Connectivity	
42. DIMENSIONS	42. DIMENSIONS	DR. M. CASSETT	TRFRT	TE Connectivity	
43. DIMENSIONS	43. DIMENSIONS	DR. M. CASSETT	TRFRT	TE Connectivity	
44. DIMENSIONS	44. DIMENSIONS	DR. M. CASSETT	TRFRT	TE Connectivity	
45. DIMENSIONS	45. DIMENSIONS	DR. M. CASSETT	TRFRT	TE Connectivity	
46. DIMENSIONS	46. DIMENSIONS	DR. M. CASSETT	TRFRT	TE Connectivity	
47. DIMENSIONS	47. DIMENSIONS	DR. M. CASSETT	TRFRT	TE Connectivity	
48. DIMENSIONS	48. DIMENSIONS	DR. M. CASSETT	TRFRT	TE Connectivity	
49. DIMENSIONS	49. DIMENSIONS	DR. M. CASSETT	TRFRT	TE Connectivity	
50. DIMENSIONS	50. DIMENSIONS	DR. M. CASSETT	TRFRT	TE Connectivity	
51. DIMENSIONS	51. DIMENSIONS	DR. M. CASSETT	TRFRT	TE Connectivity	
52. DIMENSIONS	52. DIMENSIONS	DR. M. CASSETT	TRFRT	TE Connectivity	
53. DIMENSIONS	53. DIMENSIONS	DR. M. CASSETT	TRFRT	TE Connectivity	
54. DIMENSIONS	54. DIMENSIONS	DR. M. CASSETT	TRFRT	TE Connectivity	
55. DIMENSIONS	55. DIMENSIONS	DR. M. CASSETT	TRFRT	TE Connectivity	
56. DIMENSIONS	56. DIMENSIONS	DR. M. CASSETT	TRFRT	TE Connectivity	
57. DIMENSIONS	57. DIMENSIONS	DR. M. CASSETT	TRFRT	TE Connectivity	
58. DIMENSIONS	58. DIMENSIONS	DR. M. CASSETT	TRFRT	TE Connectivity	
59. DIMENSIONS	59. DIMENSIONS	DR. M. CASSETT	TRFRT	TE Connectivity	
60. DIMENSIONS	60. DIMENSIONS	DR. M. CASSETT	TRFRT	TE Connectivity	
61. DIMENSIONS	61. DIMENSIONS	DR. M. CASSETT	TRFRT	TE Connectivity	
62. DIMENSIONS	62. DIMENSIONS	DR. M. CASSETT	TRFRT	TE Connectivity	
63. DIMENSIONS	63. DIMENSIONS	DR. M. CASSETT	TRFRT	TE Connectivity	
64. DIMENSIONS	64. DIMENSIONS	DR. M. CASSETT	TRFRT	TE Connectivity	
65. DIMENSIONS	65. DIMENSIONS	DR. M. CASSETT	TRFRT	TE Connectivity	
66. DIMENSIONS	66. DIMENSIONS	DR. M. CASSETT	TRFRT	TE Connectivity	
67. DIMENSIONS	67. DIMENSIONS	DR. M. CASSETT	TRFRT	TE Connectivity	
68. DIMENSIONS	68. DIMENSIONS	DR. M. CASSETT	TRFRT	TE Connectivity	
69. DIMENSIONS	69. DIMENSIONS	DR. M. CASSETT	TRFRT	TE Connectivity	
70. DIMENSIONS	70. DIMENSIONS	DR. M. CASSETT	TRFRT	TE Connectivity	
71. DIMENSIONS	71. DIMENSIONS	DR. M. CASSETT	TRFRT	TE Connectivity	
72. DIMENSIONS	72. DIMENSIONS	DR. M. CASSETT	TRFRT	TE Connectivity	
73. DIMENSIONS	73. DIMENSIONS	DR. M. CASSETT	TRFRT	TE Connectivity	
74. DIMENSIONS	74. DIMENSIONS	DR. M. CASSETT	TRFRT	TE Connectivity	
75. DIMENSIONS	75. DIMENSIONS	DR. M. CASSETT	TRFRT	TE Connectivity	
76. DIMENSIONS	76. DIMENSIONS	DR. M. CASSETT	TRFRT	TE Connectivity	
77. DIMENSIONS	77. DIMENSIONS	DR. M. CASSETT	TRFRT	TE Connectivity	
78. DIMENSIONS	78. DIMENSIONS	DR. M. CASSETT	TRFRT	TE Connectivity	
79. DIMENSIONS	79. DIMENSIONS	DR. M. CASSETT	TRFRT	TE Connectivity	
80. DIMENSIONS	80. DIMENSIONS	DR. M. CASSETT	TRFRT	TE Connectivity	
81. DIMENSIONS	81. DIMENSIONS	DR. M. CASSETT	TRFRT	TE Connectivity	
82. DIMENSIONS	82. DIMENSIONS	DR. M. CASSETT	TRFRT	TE Connectivity	
83. DIMENSIONS	83. DIMENSIONS	DR. M. CASSETT	TRFRT	TE Connectivity	
84. DIMENSIONS	84. DIMENSIONS	DR. M. CASSETT	TRFRT	TE Connectivity	
85. DIMENSIONS	85. DIMENSIONS	DR. M. CASSETT	TRFRT	TE Connectivity	
86. DIMENSIONS	86. DIMENSIONS	DR. M. CASSETT	TRFRT	TE Connectivity	
87. DIMENSIONS	87. DIMENSIONS	DR. M. CASSETT	TRFRT	TE Connectivity	
88. DIMENSIONS	88. DIMENSIONS	DR. M. CASSETT	TRFRT	TE Connectivity	
89. DIMENSIONS	89. DIMENSIONS	DR. M. CASSETT	TRFRT	TE Connectivity	
90. DIMENSIONS	90. DIMENSIONS	DR. M. CASSETT	TRFRT	TE Connectivity	
91. DIMENSIONS	91. DIMENSIONS	DR. M. CASSETT	TRFRT	TE Connectivity	
92. DIMENSIONS	92. DIMENSIONS	DR. M. CASSETT	TRFRT	TE Connectivity	
93. DIMENSIONS	93. DIMENSIONS	DR. M. CASSETT	TRFRT	TE Connectivity	
94. DIMENSIONS	94. DIMENSIONS	DR. M. CASSETT	TRFRT	TE Connectivity	
95. DIMENSIONS	95. DIMENSIONS	DR. M. CASSETT	TRFRT	TE Connectivity	
96. DIMENSIONS	96. DIMENSIONS	DR. M. CASSETT	TRFRT	TE Connectivity	
97. DIMENSIONS	97. DIMENSIONS	DR. M. CASSETT	TRFRT	TE Connectivity	
98. DIMENSIONS	98. DIMENSIONS	DR. M. CASSETT	TRFRT	TE Connectivity	
99. DIMENSIONS	99. DIMENSIONS	DR. M. CASSETT	TRFRT	TE Connectivity	
100. DIMENSIONS	100. DIMENSIONS	DR. M. CASSETT	TRFRT	TE Connectivity	