

4

3

2

1

THIS DRAWING IS UNPUBLISHED. RELEASED FOR PUBLICATION
 © COPYRIGHT BY TYCO ELECTRONICS CORPORATION. ALL INTERNATIONAL RIGHTS RESERVED.

LOC H
 DIST -

| REVISIONS | | | | | |
|-----------|-----|---------------|----------|-----|------|
| P | LTR | DESCRIPTION | DATE | OWN | APVD |
| L | | EH-1518-99 | 20-09-99 | MVE | - |
| M | | ECR-06-013127 | 31-05-06 | MO | - |
| M1 | | ECR-08-012368 | 06-07-08 | AEG | WRV |

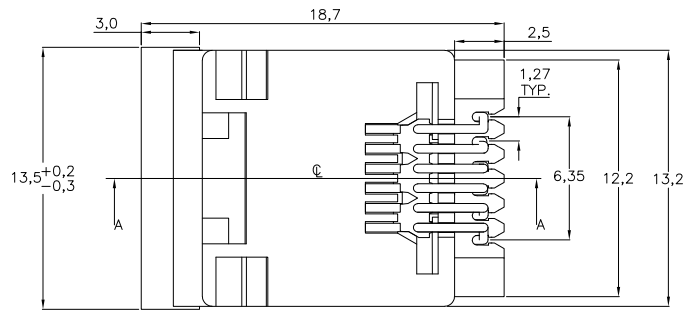

- NOTES:
1. TOLERANCES UNLESS OTHERWISE SPECIFIED: ±0.15
 2. CONTACTS:
1.25µm MIN. GOLD OVER 1.25µm MIN. NICKEL IN CONTACT AREA.
2.0µm MIN. TIN OVER 1.25µm MIN. NICKEL ON SOLDER TINES.
 3. HOUSING:
30% C.F. PA 4.6, COLOR BLACK, UL 94V-0 CONTACTS:
PHOSPHOR BRONZE
ADDITIONAL SOLDERJOINT:
TIN PLATED BRASS
 4. MODULAR JACKS ARE DELIVERED TAPE MOUNTED ON REEL. SEE SHEET 2.
 5. PRODUCT SPECIFICATION: 108-19117.
APPLICATION SPECIFICATION: 114-19041.
 6. SOLDER PASTE THICKNESS 0,15mm (=0.006") MIN.

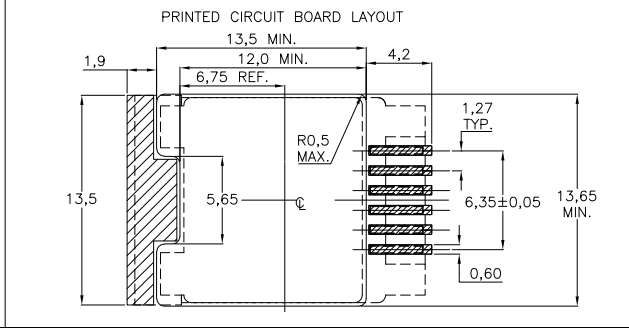
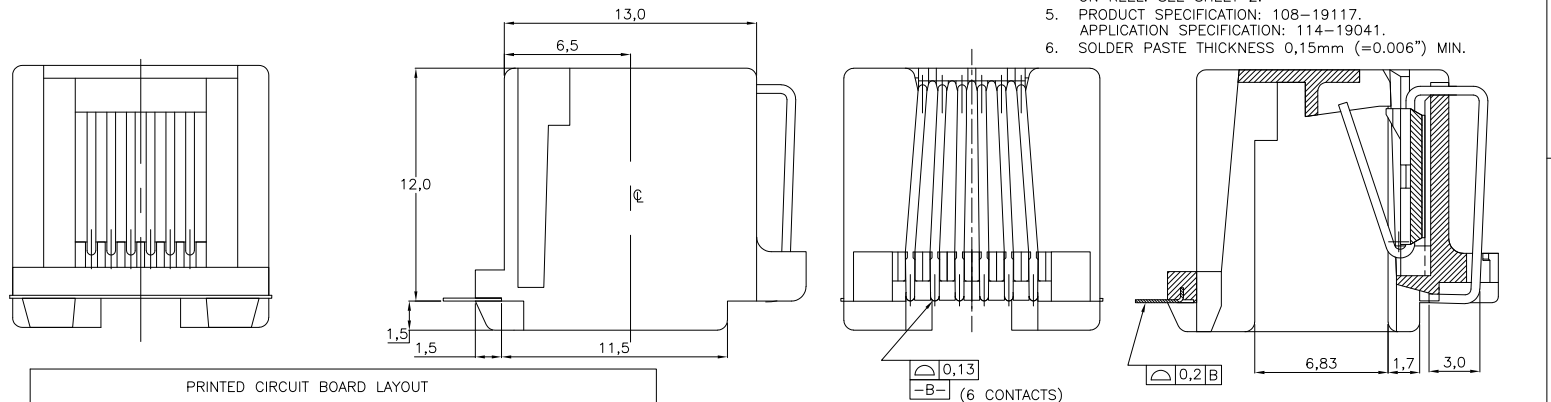

| | | | | | |
|--|--|-----------------------|----------------------|---|--------------------|
| THIS DRAWING IS A CONTROLLED DOCUMENT. | | OWN D. CAMPSCHROER | 27JAN92 | Tyco Electronics Corporation 's-Hertogenbosch, Nederland | |
| DIMENSIONS: mm | | CHK W. BRUMMANS | NAME L. VAN SOEST | MODULAR JACK, 6 POSITION BOTTOM ENTRY FOR SURFACE MOUNT APPLICATION | |
| TOLERANCES UNLESS OTHERWISE SPECIFIED: | | APPLICATION SPEC | | SIZE A3 | CAGE CODE 00779 |
| 0 PLC ± - | | WEIGHT | | DRAWING NO C=100860 | |
| 1 PLC ± - | | CUSTOMER DRAWING | | RESTRICTED TO | |
| 2 PLC ± - | | SCALE NTS | | SHEET 1 of 4 | |
| 3 PLC ± - | | MATERIAL | | REV M1 | |
| 4 PLC ± - | | FINISH | | | |
| ANGLES ± - | | | | | |
| SEE TABLE | | | | | |

4

3

2

1

THIS DRAWING IS UNPUBLISHED. RELEASED FOR PUBLICATION
 © COPYRIGHT - BY TYCO ELECTRONICS CORPORATION. ALL RIGHTS RESERVED.

| LOC | DIST | REVISIONS | | | |
|-----|------|-------------|------|-----|------|
| P | LTR | DESCRIPTION | DATE | DWN | APVD |
| H | - | SEE SHEET 1 | - | - | - |

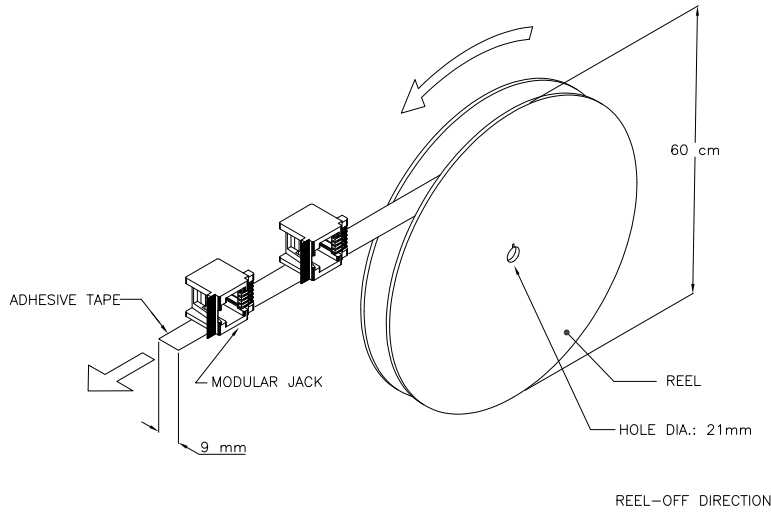

| | | |
|---------------------|--|------------|
| 6 POS. / 6 CONTACTS | TAPE MOUNTED ON 60 cm. DIA. REEL (700 pcs/reel) | 100860-1 |
| DESCRIPTION | PACKAGING | PARTNUMBER |

| | | | | | |
|--|--|----------------------|--------------|---|---------------|
| THIS DRAWING IS A CONTROLLED DOCUMENT. | | DWN J. TUIJN | 06AUG93 | Tyco Electronics Corporation 's-Hertogenbosch, Nederland | |
| DIMENSIONS: mm | | CHK W. BRUMMANS | NAME | MODULAR JACK, 6 POSITION BOTTOM ENTRY FOR SURFACE MOUNT APPLICATION | |
| TOLERANCES UNLESS OTHERWISE SPECIFIED: | | APVD L. VAN SOEST | PRODUCT SPEC | SIZE | RESTRICTED TO |
| 0 PLC ± - | | APPLICATION SPEC | --- | A3 | --- |
| 1 PLC ± - | | WEIGHT | --- | 00779 | --- |
| 2 PLC ± - | | FINISH | --- | C=100860 | --- |
| 3 PLC ± - | | MATERIAL | --- | CUSTOMER DRAWING | |
| 4 PLC ± - | | | | SCALE | SHEET |
| ANGLES ± - | | | | NTS | 2 of 4 |
| | | | | | REV M1 |

AMP 1470-19 REV 31MAR2000

4

3

2

1

THIS DRAWING IS UNPUBLISHED. RELEASED FOR PUBLICATION
 © COPYRIGHT BY TYCO ELECTRONICS CORPORATION. ALL RIGHTS RESERVED.

| LOC | DIST | REVISIONS | | | | |
|-----|------|-------------|------|-----|------|--|
| P | LTR | DESCRIPTION | DATE | OWN | APVD | |
| H | - | SEE SHEET 1 | - | - | - | |

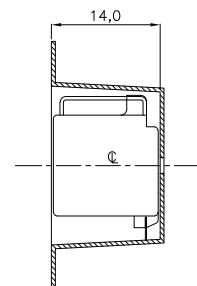
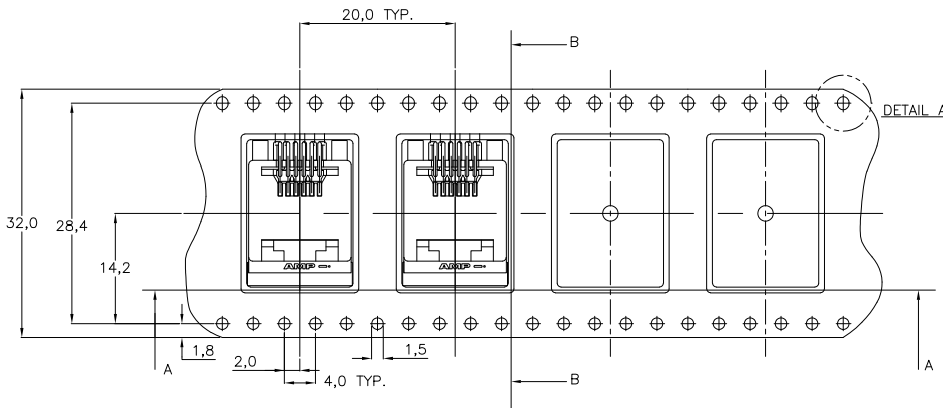

REEL OFF DIRECTION

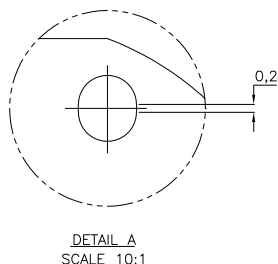
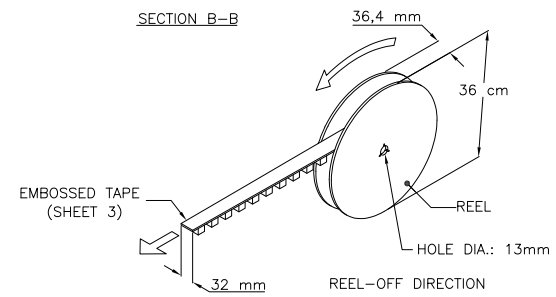
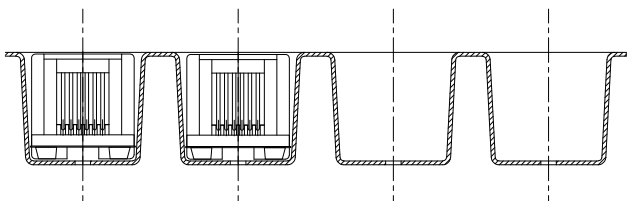

| | | |
|--|--|--|
| 6 POS. / 6 CONTACTS | EMBOSSD TAPE ACC. TD EIA 481-3 (36 cm. DIA. REEL)(300 pcs/reel) | 2-100860-1 |
| DESCRIPTION | PACKAGING | PARTNUMBER |
| THIS DRAWING IS A CONTROLLED DOCUMENT. OWN: E. V. ELJK 03DEC96 CHK: F. STELLINGA APVD: R. SMEETS Tyco Electronics Tyco Electronics Corporation 's-Hertogenbosch, Nederland | | |
| DIMENSIONS: mm TOLERANCES UNLESS OTHERWISE SPECIFIED: 0 PLC ± - 1 PLC ± - 2 PLC ± - 3 PLC ± - 4 PLC ± - ANGLES ± - MATERIAL FINISH | | MODULAR JACK 6 POS. PACKAGING SIZE: A3 CAGE CODE: 00779 DRAWING NO: C=100860 WEIGHT: - CUSTOMER DRAWING |
| SCALE: NTS | | SHEET: 3 of 4 REV: M1 |

4

3

2

1

THIS DRAWING IS UNPUBLISHED. RELEASED FOR PUBLICATION
 © COPYRIGHT - BY TYCO ELECTRONICS CORPORATION. ALL RIGHTS RESERVED.

| LOC | DIST | REVISIONS | | | |
|-----|------|-------------|------|-----|------|
| P | LTR | DESCRIPTION | DATE | OWN | APVD |
| H | - | SEE SHEET 1 | - | - | - |

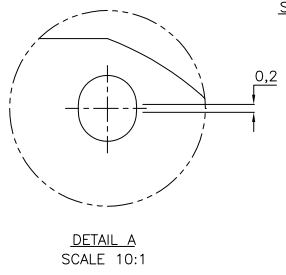
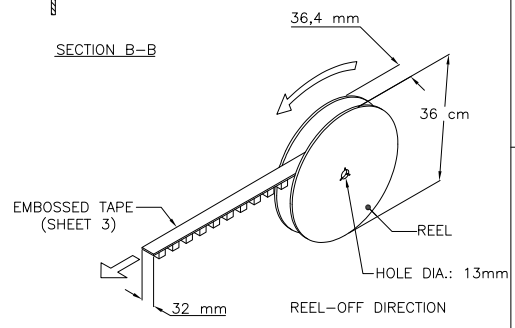
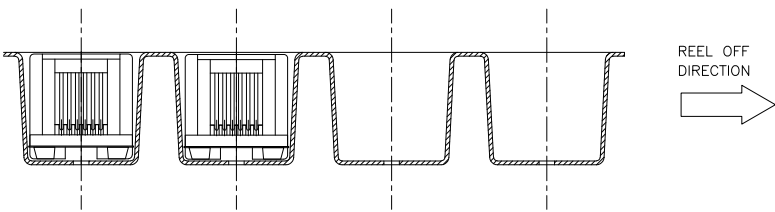
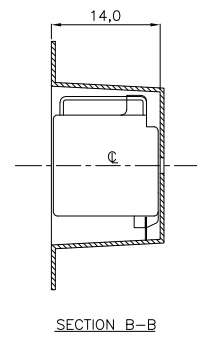
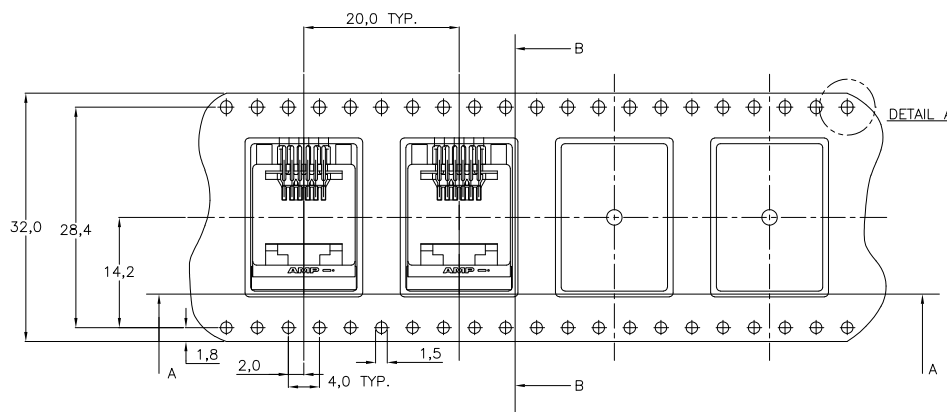

| | | | |
|--|---------------------|--|------------------------------------|
| OBSOLETE | 6 POS. / 6 CONTACTS | EMBOSSD TAPE ACC. TD EIA 481-3 (36 cm. DIA. REEL)(300 pcs/reel) | 3-100860-1 |
| DESCRIPTION | | PACKAGING | PARTNUMBER |
| THIS DRAWING IS A CONTROLLED DOCUMENT. | | | |
| DIMENSIONS: mm | | OWN: E. V. ELJK | 03DEC96 |
| TOLERANCES UNLESS OTHERWISE SPECIFIED: | | CHK: F. STELLINGA | |
| 0 PLC | ± - | APVD: R. SMEETS | NAME: Tyco Electronics Corporation |
| 1 PLC | ± - | PRODUCT SPEC | 's-Hertogenbosch, Nederland |
| 2 PLC | ± - | APPLICATION SPEC | MODULAR JACK 6 POS. PACKAGING |
| 3 PLC | ± - | WEIGHT | |
| 4 PLC | ± - | SIZE | A3 |
| ANGLES | ± - | CAGE CODE | 00779 |
| MATERIAL | FINISH | DRAWING NO | ©=100860 |
| | | RESTRICTED TO | |
| CUSTOMER DRAWING | | SCALE | NTS |
| | | SHEET | 4 of 4 |
| | | REV | M1 |

AMP 1470-19 REV 31MAR2000