

REVISIONS			
SYM ZONE	ECN, ERN NO.	DATE	APPRD.
A	PROPOSAL	09/04/07	

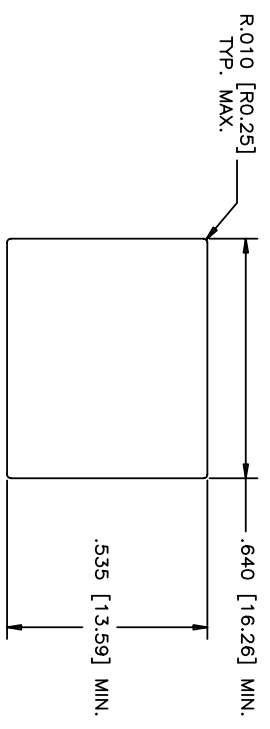
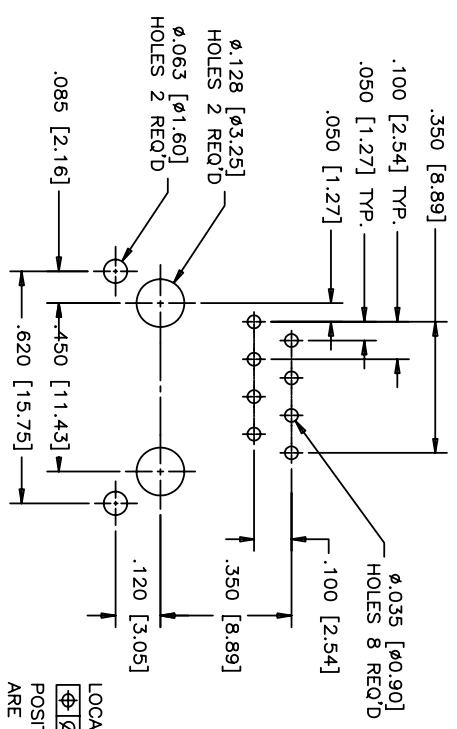
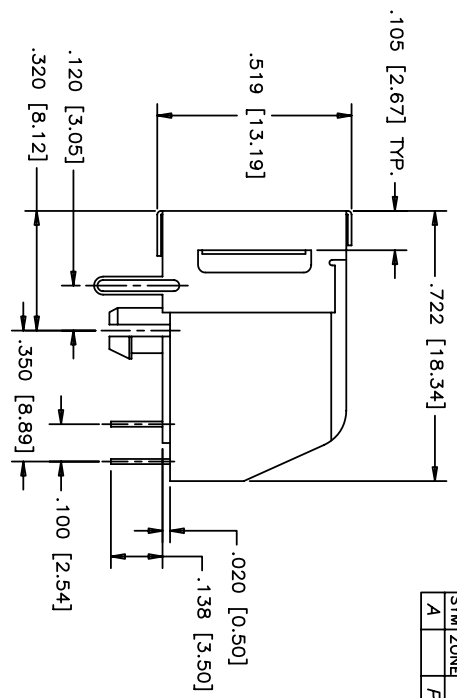
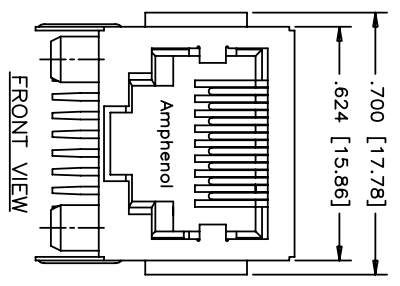

AMPHENOL PART NUMBER: RJE03-188-2X20

MATERIALS:
 PLASTIC HOUSING: ENGINEERING THERMOPLASTIC
 FLAMMABILITY RATING UL94V-0

CONTACTS:
 PHOSPHOR BRONZE
 GOLD PLATING(PER P/N TABLE),
 OVER NICKEL,
 TIN PLATING TAILS

SHIELD:
 COPPER ALLOY, NICKEL PLATED

- 1 = 06 μ" GOLD
- 2 = 15 μ" GOLD
- 3 = 30 μ" GOLD
- 4 = 50 μ" GOLD

RECOMMENDED PANEL CUTOUT

THIS DOCUMENT CONTAINS PROPRIETARY INFORMATION AND SUCH INFORMATION MAY NOT BE DISCLOSED TO OTHERS FOR ANY PURPOSE OR USED FOR MANUFACTURING PURPOSES WITHOUT WRITTEN PERMISSION FROM AMPHENOL CANADA CORP.

DESIGNED	PAUL WANG	DATE	09/04/07
CHECKED			
ENG. REL. NO.			
DWG. APPRD.			
REF. EAR#	12704	DWG. DRAWING NO.	P-RJE03-188-2X20
DIMENSIONS ARE IN INCHES (mm)	03554	SCALE	1
TITLE		Amphenol Canada Corp.	
MODULAR JACK, PARTIAL SHIELD			
8 POSITION, 8 CONTACTS, WITH			
SIDE FLANGES - ROHS COMPLIANT			
REV.	A	REV.	A

