

THIS DRAWING IS UNPUBLISHED
 ALL RIGHTS RESERVED

| REV | DATE | DESCRIPTION | BY | CHK | APP |
|-----|------|--------------------------|----|-----|-----------------|
| AA | 00 | | | | |
| CI | | REVISED PER EDD-11-00503 | | | 24MAR11 RJK HMR |

1. MATERIAL:
 HOUSING - PBT POLYESTER, COLOR: BLACK
 TERMINAL - 0.36[.014] THICK PHOS BRONZE PLATED WITH 1.27μm [.000050] THICK HARD GOLD IN LOCALIZED GOLD PLATE AREA AND 3.81μm [.000150] THICK MATTE TIN IN SOLDER AREA OVER 1.27μm [.000050] THICK NICKEL UNDERPLATE
 SHIELD - 0.25 [.010] THICK COPPER ALLOY PLATED WITH 3.0μm [.000120] MINIMUM THICK REFLOWED TIN
- △ CAVITY CONFORMS TO FCC RULES AND REGULATIONS PART 68, SUBPART F.
- △ DIMENSIONS MEASURED ALONG FRONT EDGES OF MATING FACE

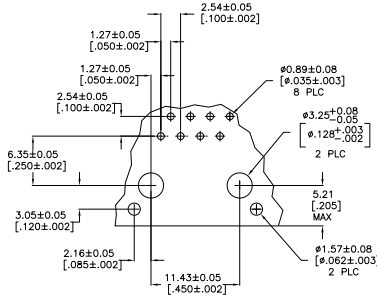
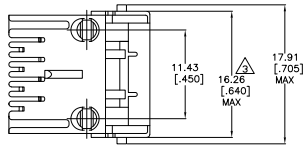
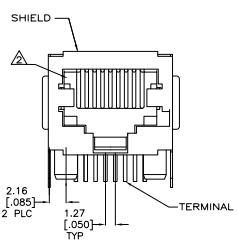
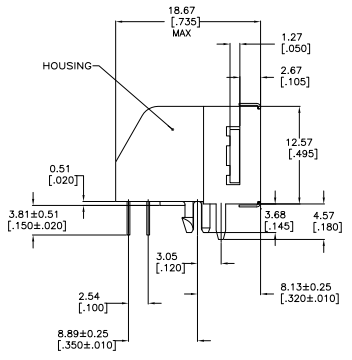

RECOMMENDED PRINTED CIRCUIT BOARD LAYOUT
 (COMPONENT SIDE)

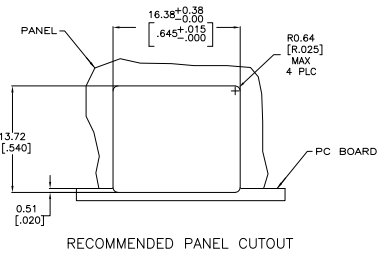

RECOMMENDED PANEL CUTOUT

5556591-1
 PART NUMBER

| | | | | | | | |
|---|--|------------------|---------------|-------------|------------------|---------------|-------------|
| THIS DRAWING IS A CONTROLLED DOCUMENT. | | DATE: 11/11/2007 | BY: J.A.MAYER | REV: 000007 | DATE: 11/11/2007 | BY: J.A.MAYER | REV: 000007 |
| UNLESS OTHERWISE SPECIFIED, DIMENSIONS ARE IN INCHES. | UNLESS OTHERWISE SPECIFIED, DIMENSIONS ARE IN MILLIMETERS. | DATE: 11/11/2007 | BY: J.A.MAYER | REV: 000007 | DATE: 11/11/2007 | BY: J.A.MAYER | REV: 000007 |
| 1. SEE NOTE 1 | 1. SEE NOTE 1 | DATE: 11/11/2007 | BY: J.A.MAYER | REV: 000007 | DATE: 11/11/2007 | BY: J.A.MAYER | REV: 000007 |
| CUSTOMER DRAWING | | DATE: 11/11/2007 | BY: J.A.MAYER | REV: 000007 | DATE: 11/11/2007 | BY: J.A.MAYER | REV: 000007 |