

# Modular Jack Connector for High-Speed Transmission

## TM24R Series

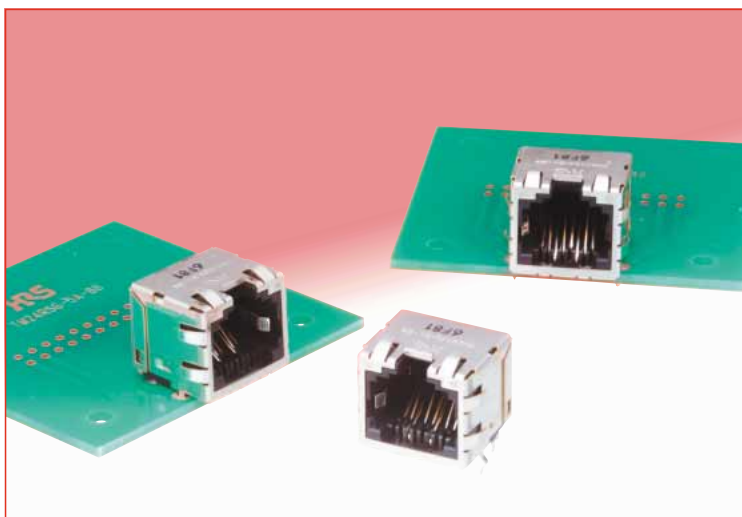

### ■ Features

#### 1. Unique contact configuration (Patented) and board-mounting pattern

The adjacent contacts have different angles of engagement thus increasing the distance between them, in effect reducing the cross talk within connector and its footprint.

Contact #3 and #6, affecting the cross talk the most; have been isolated from other contacts resulting in maximum NEXT noise suppression.

In addition, the board layout allows easy tracing of the differential signal lines.

#### 2. Full EMI shielding

The entire connector is covered with a metal shell.

Multiple panel ground contact springs (2 on each side of the mating opening) and 4 board ground connection solder contacts placed at each corner of the connector guarantee effective suppression of noise radiation.

#### 3. Sequential mating

Separate ground springs (Patent pending) make contact with the mating connector's ground before the signal contacts, allowing equalization of any ground differential.

#### 4. Conforms to FCC (Federal Communications Commission) standards

Meets requirements of FCC Title 47, Part 68, Subpart F.

### ■ Applications

LAN related equipment, measuring instruments, office equipment and other high transmission speed applications requiring use of high performance modular jacks.

### Unique Contact Configuration

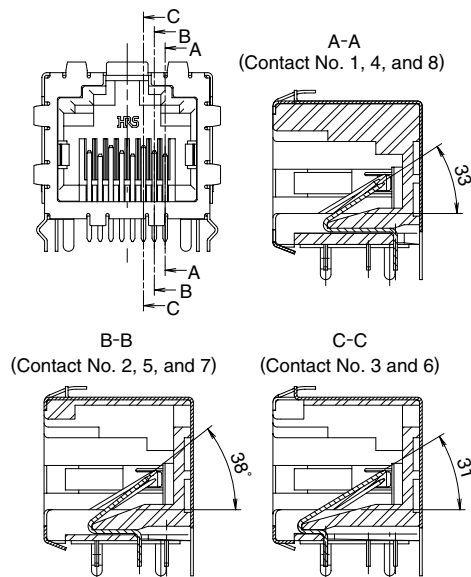

### Recommended board layout for differential routing

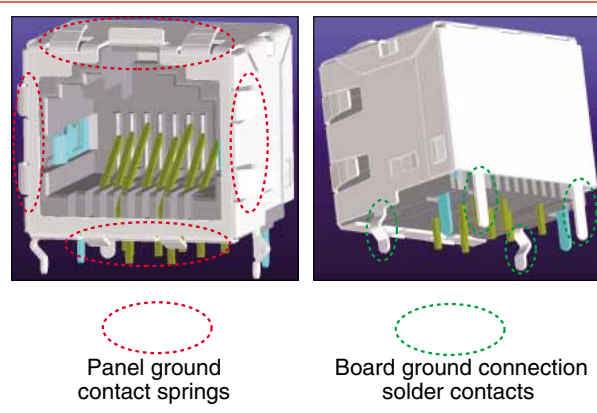
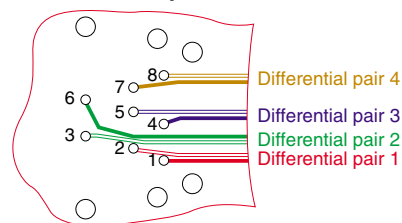

### Separate ground springs

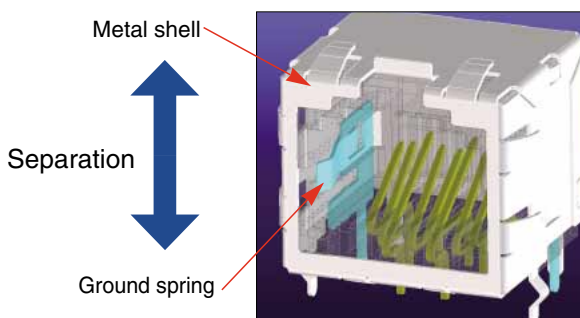

## TM24 Series Modular Jack Connector for High-Speed Transmission

### Product Specifications

Ratings	Current rating 1A Voltage rating 125V AC	Operating temperature range: -25°C to +80°C (Note)
---------	---	--

Item	Specification	Conditions
1. Insulation resistance	100M ohms min.	100V DC
2. Withstanding voltage (Basic terminal between 123-456-78)	No flashover or insulation breakdown.	500V AC / one minute
3. Withstanding voltage (Terminal to shield)	No flashover or insulation breakdown.	1500V AC / one minute
4. Contact resistance	50m ohms max.	100mA
5. Vibration	No electrical discontinuity of 5μs or more. No damage, cracks, or parts dislocation.	Frequency: 10 to 55 Hz, single amplitude of 0.75mm, 3 axis, 10 cycles
6. Shock	No electrical discontinuity of 5μs or more. Contact resistance: 60 m ohms max.	Acceleration of 490 m/s <sup>2</sup> , 11 ms duration, sine half-wave waveform, 3 cycles / each of 6 axis
7. Durability (insertion/withdrawal)	Contact resistance: 60 m ohms max.	700 cycles
8. Temperature cycle	Insulation resistance: 100 M ohms min. Contact resistance: 60 m ohms max.	(Temperature: -55°C → +15°C to +35°C → +85 → +15°C to +35°C Duration: 30 → 2 to 3 → 30 → 2 to 3 (Minutes) 5 cycles
9. Humidity	Insulation resistance: 1 M ohms min. (High humidity) Insulation resistance: 10 M ohms min. (Dry state)	500 hours at 40°C, HR 90% to 95%
10. Salt spray	Contact resistance: 60 m ohms max.	5% water solution for 48 hours

Note: Includes temperature rise caused by current flow.  
 Temperature range for mechanical operation : -25°C to +60°C

### Materials

Part	Material	Finish	Remarks
Insulator	PBT	Color: Black	UL94V-0
Contact	Phosphor bronze	Contact area: Gold plated 1.27 μm Termination area: Gold plated 0.03 μm Under plate: Nickel plated 1 μm	————
Shield	Brass	Tin reflow plated 1 μm	————
Ground spring	Phosphor bronze	Tin reflow plated 1 μm	————

### Ordering information

**TM24 R SG - 5A - 8 8**  
 ① ② ③ ④ ⑤ ⑥

① Series name	: TM24
② Connector type	: R... Jack
③ Shell type	: SG... Separate ground spring –outer shell
④ Jack type	: 5A... Right-angle dip
⑤ Jack opening code	: 8... 8 contacts
⑥ Number of inserted contact	: 8... 8 contacts

## Modular Jack Connectors

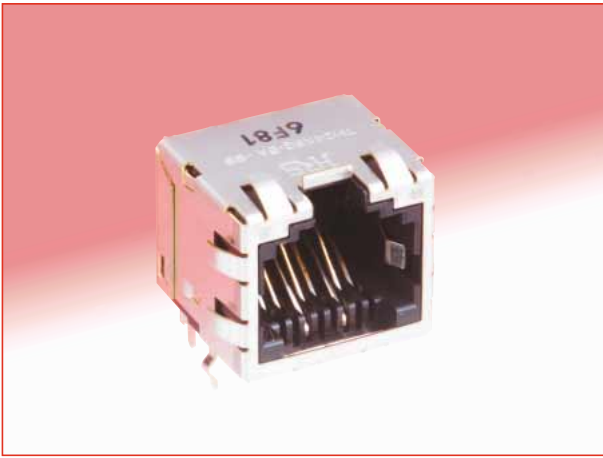

Part number	CL No.	RoHS
TM24RSG-5A-88	222-2946-7-00	YES

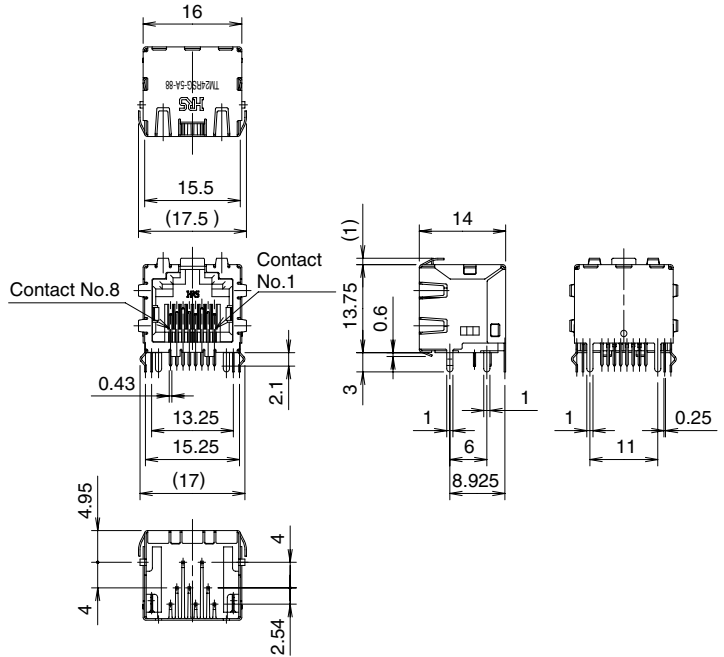

### Recommended PCB mounting pattern

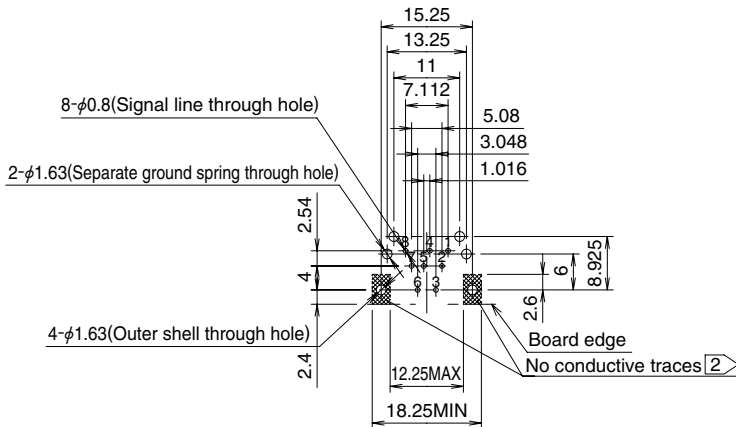

### Recommended panel cutout

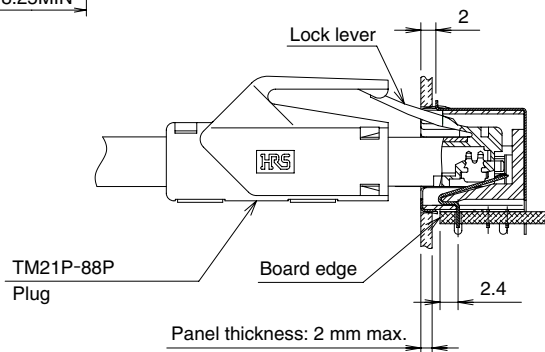
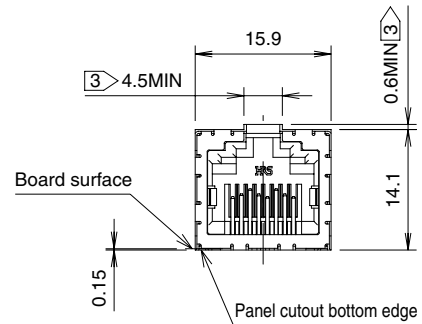

#### \* Precautions and recommendations for board and panel design

- 1 . Recommended board thickness: 1.6 mm.
- [2] . No conductive traces in the crosshatched areas.
- [3] . Make sure that the panel cutout has enough clearance to assure free operation of the lock lever of the mating plug.
- 4 . Make sure that the panel cutout bottom edge is 0.15 mm below the board-mounting surface.
- 5 . Connector can be cleaned with isopropyl alcohol (IPA) at room temperature.

## Signal Integrity Data

These are the representative values of the electrical performance demanded for modular connectors according to IEEE802.3-an (10GBASE-T).

### Measurement Outline Drawing

Measurement point : FEXT → Sdd21

Return Loss → Sdd11

Impedance Balance → Scd11

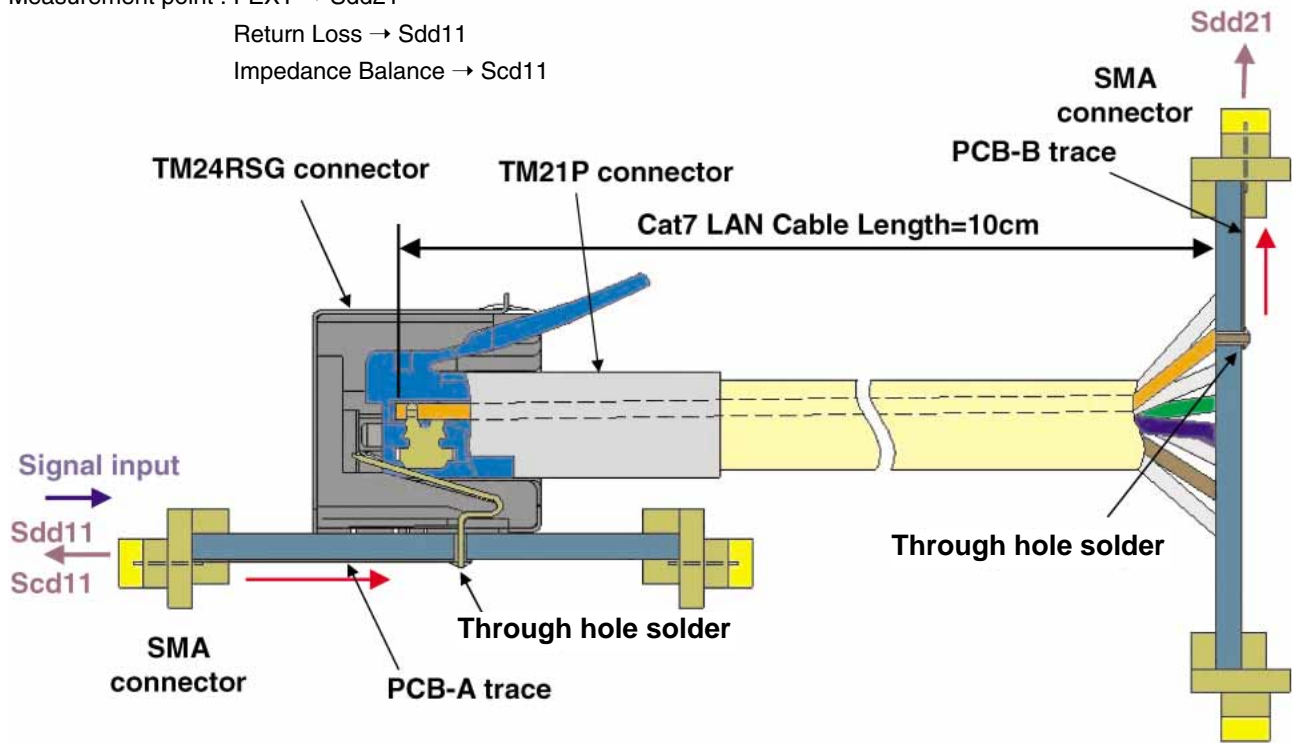

### FEXT Data

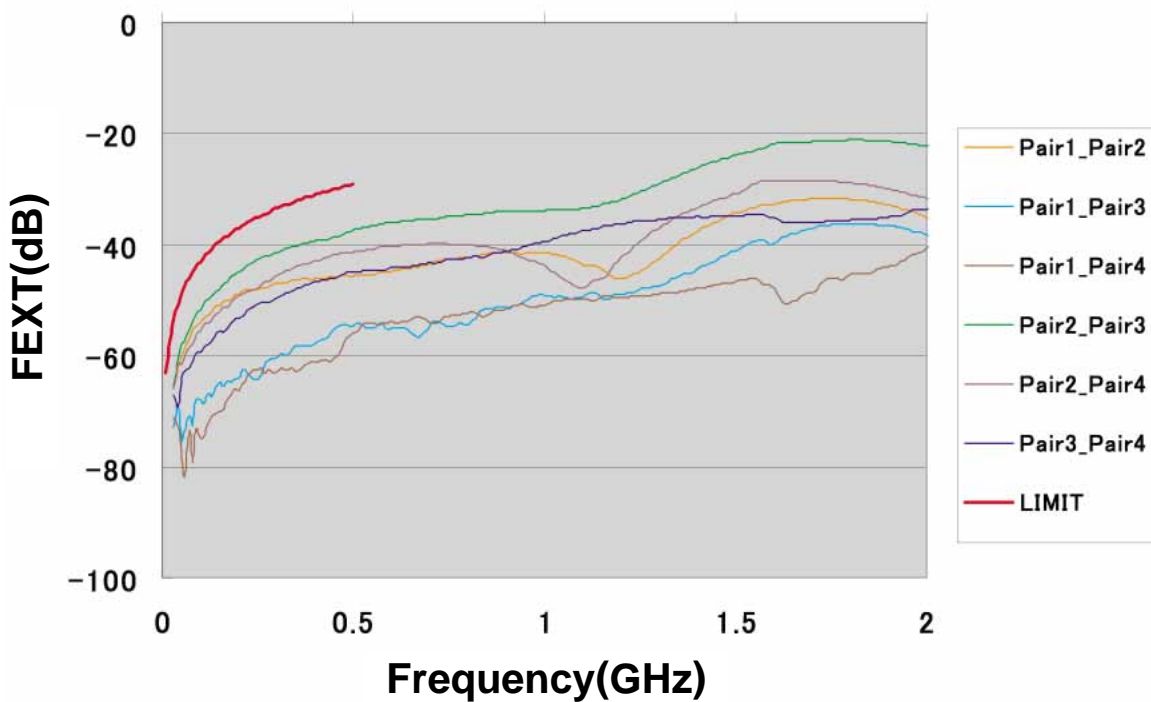

● Return Loss Data

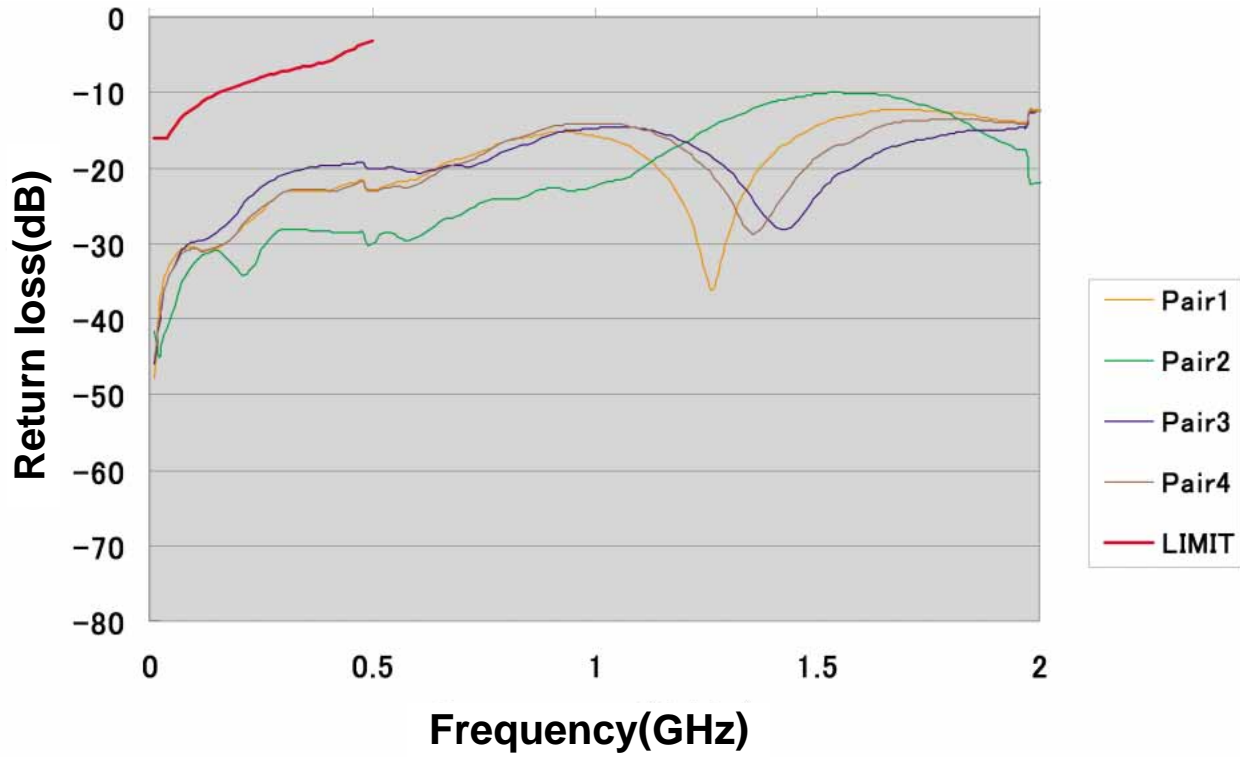

● Impedance Balance Data

