

THIS DRAWING IS UNPUBLISHED. ALL RIGHTS RESERVED. IN THE ELECTRONICS CORPORATION. ALL INFORMATION SHOWN HEREON IS UNCLASSIFIED.

REV	DATE	DESCRIPTION	BY	CHK	APP
B	REV. EC: 027A-0002-98		ZMMLM	SG	SH
C	SUPSD-1, REV ECI-18-936%		EDPMP	LH	SH

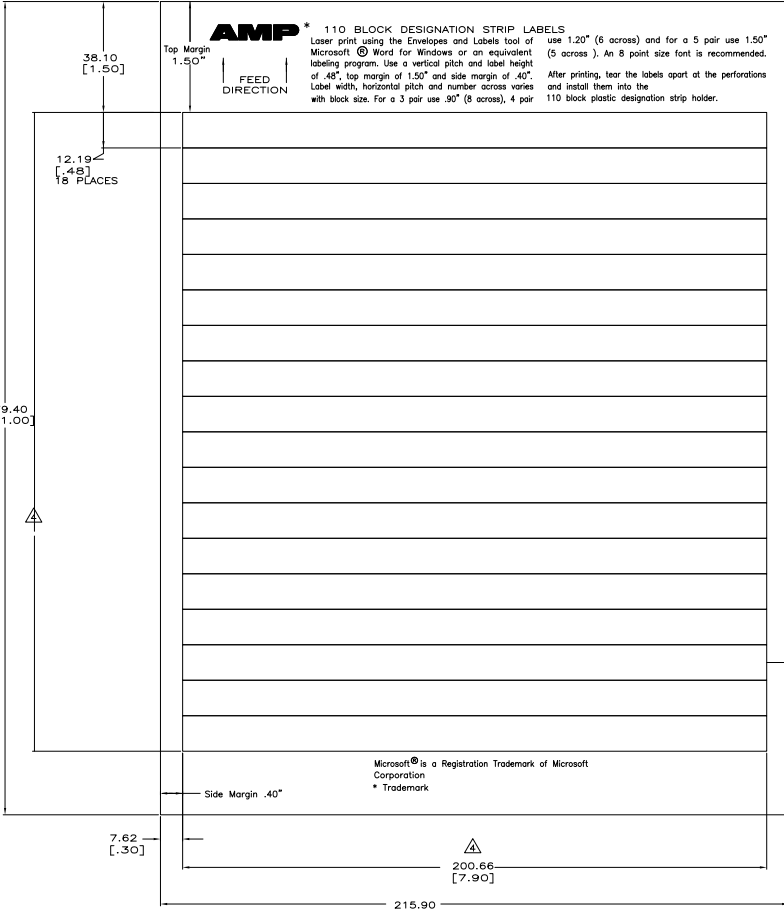

- △ MATERIAL: 0.1905 [0.075] THICK LASER PRINTABLE RED LABELS.
- 2. TEN SHEETS OF LABELS PER PACKAGE. 18 LABELS PER SHEET. TOTAL OF 180 LABELS PER PACKAGE.
- 3. INDIVIDUAL LABELS SEPARATED BY PERFORATIONS ON EACH SHEET.
- △ AREA TO BE COLORED RED.
- △ SEE RESTRICTED CUSTOMER DRAWING 3-1116035-1.

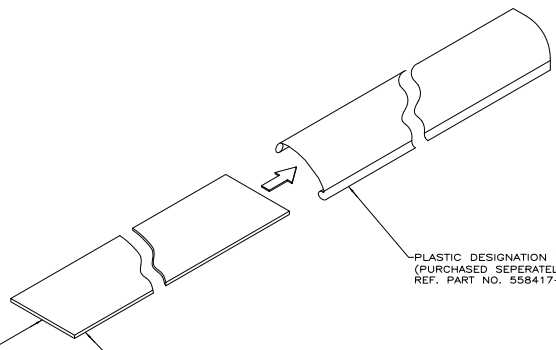

SUPSD BY 1375354-5	1116035-1
	PART NO.

THIS DRAWING IS A CONTROLLED DOCUMENT.		BY: GABRIEL	TRWBY: T	DATE: 11/10/98	REV: 1	DESCRIPTION: STRIPS, DESIGNATION, RED
UNLESS OTHERWISE SPECIFIED:	UNIT: INCHES	SCALE: AS SHOWN	TOLERANCES:	DECIMALS	FRACTIONS	ANGLES
FRACTIONS	DECIMALS	ANGLES	AS SHOWN	AS SHOWN	AS SHOWN	AS SHOWN
UNLESS OTHERWISE SPECIFIED:	UNIT: INCHES	SCALE: AS SHOWN	TOLERANCES:	DECIMALS	FRACTIONS	ANGLES
FRACTIONS	DECIMALS	ANGLES	AS SHOWN	AS SHOWN	AS SHOWN	AS SHOWN
DATE: 11/10/98	DRAWING NO: 1116035	REVISED TO:	CUSTOMER DRAWING	DATE: 11/10/98	REV: 1	DESCRIPTION: STRIPS, DESIGNATION, RED

SHEET PRINTING LAYOUT