

| REVISED | | REVISIONS | |
|---------|---------|-------------------------|----|
| REV | DATE | DESCRIPTION | BY |
| A | 1/20/07 | RELEASED: NPR NS007-013 | GG |
| B | 1/20/07 | REV ECO-11-000935 | LN |

⚠ MATERIAL:
 BASE, COVER AND EXTENDER - ABS MOLDING COMPOUND.
 SEE TABLE FOR COLOR.
 FOAM TAPE - DOUBLE SIDED ADHESIVE, POLYETHYLENE.
 SCREWS - ZINC PLATED CARBON STEEL.

⚠ DIMENSIONS ARE NOMINAL UNLESS OTHERWISE SPECIFIED.

3. KIT SHIPPED NOT ASSEMBLED.

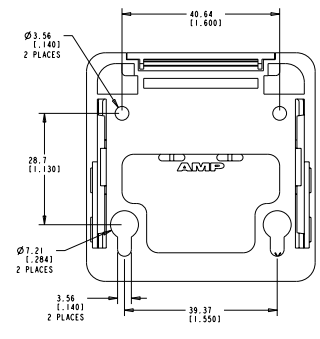
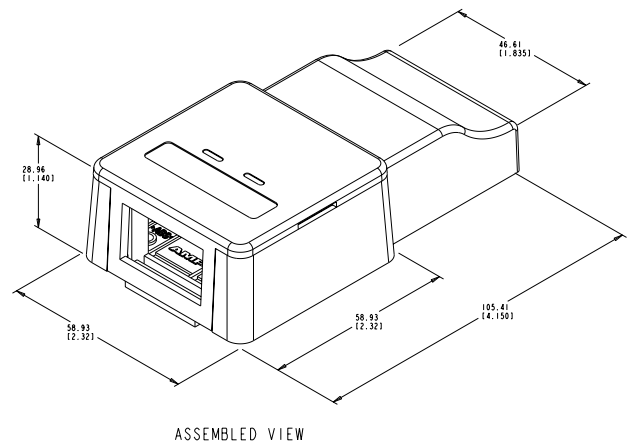
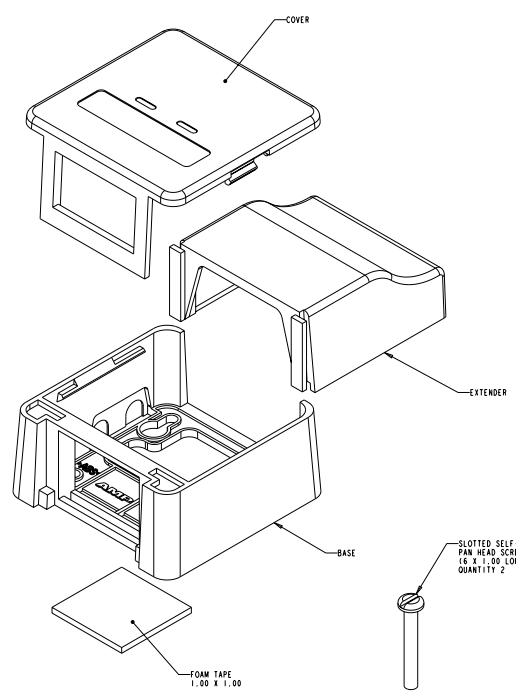

| COLOR | PART NUMBER |
|----------------|-------------|
| ELECTRIC IVORY | 1-1933287-1 |
| NEMA GRAY | 1933287-4 |
| WHITE | 1933287-3 |
| BLACK | 1933287-2 |
| LIGHT ALMOND | 1933287-1 |

| | | | | | |
|--|--|--|--|--|--|
| APPROVED FOR RELEASE BY THE ELECTRONIC COMPONENTS COMPANY DATE: 1/20/07 BY: LN | APPROVED FOR RELEASE BY THE ELECTRONIC COMPONENTS COMPANY DATE: 1/20/07 BY: LN | APPROVED FOR RELEASE BY THE ELECTRONIC COMPONENTS COMPANY DATE: 1/20/07 BY: LN | APPROVED FOR RELEASE BY THE ELECTRONIC COMPONENTS COMPANY DATE: 1/20/07 BY: LN | APPROVED FOR RELEASE BY THE ELECTRONIC COMPONENTS COMPANY DATE: 1/20/07 BY: LN | APPROVED FOR RELEASE BY THE ELECTRONIC COMPONENTS COMPANY DATE: 1/20/07 BY: LN |
| AMP Incorporated Harrisburg, PA 17105-3600 | | | | | |
| KIT, OFFICE BOX, EXTENDER, 2 PORT | | | | | |
| STATE CASE CODE (SEE PAGE 40) 00778 ©-1933287 | | | | | |
| CUSTOMER DRAWING | | | | | |