

| REV | DATE    | BY  | CHKD | APP'D |
|-----|---------|-----|------|-------|
| 0   | 14SEP99 | TLP | RM   |       |
| A   | 20MAR00 | GG  | GB   |       |
| B   | 03OCT00 | GG  | GB   |       |

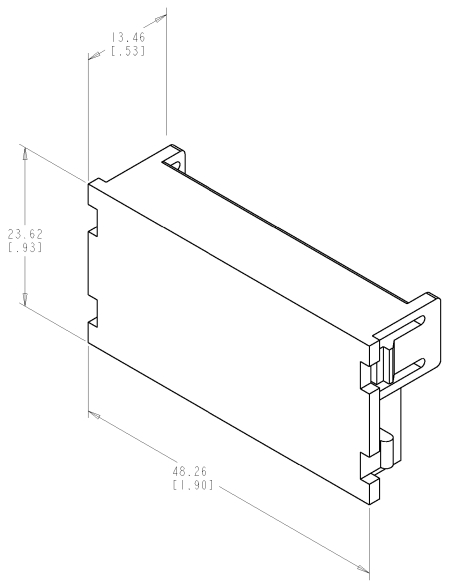

- △ MATERIAL: ABS MOLDING COMPOUND. SEE TABLE FOR COLOR.
- DIMENSIONS ARE NOMINAL UNLESS OTHERWISE SPECIFIED.
  - REFER TO INSTRUCTION SHEET 408-8398 FOR INSTALLATION PROCEDURES.

| COLOR          | PART NUMBER |
|----------------|-------------|
| ELECTRIC IVORY | 1-1116410-1 |
| NEMA GRAY      | 1116410-4   |
| WHITE          | 1116410-3   |
| BLACK          | 1116410-2   |
| LIGHT ALMOND   | 1116410-1   |

|                            |  |   |  |   |   |
|----------------------------|--|---|--|---|---|
| DIMENSIONS:<br>mm( INCHES) |  | TOLERANCES UNLESS OTHERWISE SPECIFIED:<br>DIMENSIONS: ±.25<br>ANGLES: ±.5 |  | DWN: T. ELITS 14SEP99<br>CHK: B. MARTIN 18NOV99<br>APP: B. MARTIN 09DEC99 | AMP Incorporated<br>Harrisburg, PA 17105-3408       |
| MATERIAL:                  |  | FINISH: -   |  | WEIGHT: -   | SIZE: A2<br>CASE CODE: 00779<br>DRAWING NO: 1116410 |
| CUSTOMER DRAWING           |  |   |  | SCALE: 4:1  | SHEET 1 OF 1 REV B                                  |