

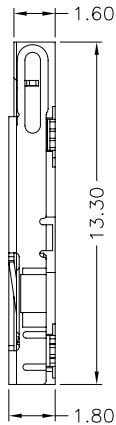

Part Number:101-00303-**
Micro SD Card Conn.

- Non push type
- SMT
- Application for mobile phones, PDAs, MP3 players, digital still cameras

- 1.Materials:
 Housing: High temperature thermoplastic, UL 94V-0 rated.
 Contact: Copper alloy
 Cover: SUS304
 Ground: Copper alloy selective gold 1u" flash plating, over nickel plating (50U" min)
- 2.Contact finish:
 Selective 1~15u" gold on contact area plating, tin 160u" at solder tail, over nickel plating (50U" min)
- 3.Electrical specifications:
 Voltage Rating:100VAC
 Current Rating:0.5A per contact
 Dielectric strength:500VAC initial and 250VAC final for one minute
 Insulation Resistance: 1000MΩ min at 500VDC
 Contact Resistance: 100mΩ max at 100mA
 Operating temperature:-25°C~+85°C
- 4.Mechanical specifications:
 Durability: 5000cycles.
- 5.RoHS Compliant

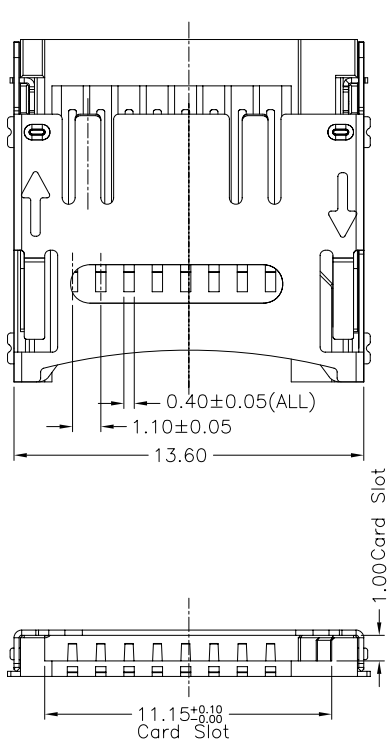

Pin assignment	
Pin No.	Name
1	DAT2
2	CD/DAT3
3	CMD
4	VDD
5	CLK
6	VSS
7	DAT0
8	DAT1

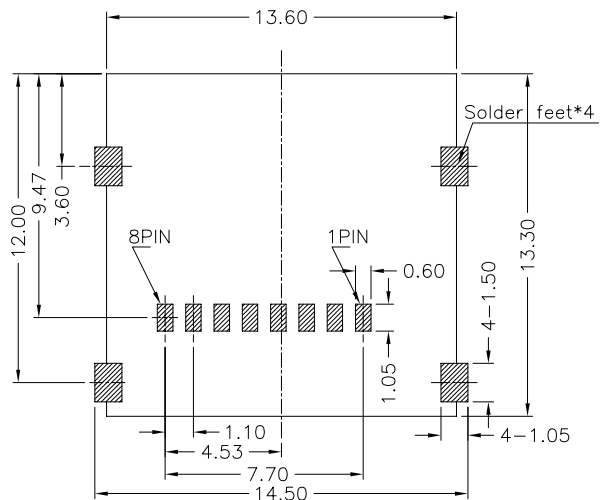

Recommended PCB layout
 Top view(Tolerance: ±0.05)
 ■ Land area □ Keep out area

