

NUMBER  
C-1734027

METRIC

PRINT DIST DW

THIS INFORMATION IS CONFIDENTIAL AND IS RELEASED TO YOU ON CONDITION THAT NO PARTS OR INFORMATION IS MADE BY YOU TO OTHER THAN AMP PERSONNEL WITHOUT DIMENSIONS IN MILLIMETERS. DO NOT SCALE PRINT.

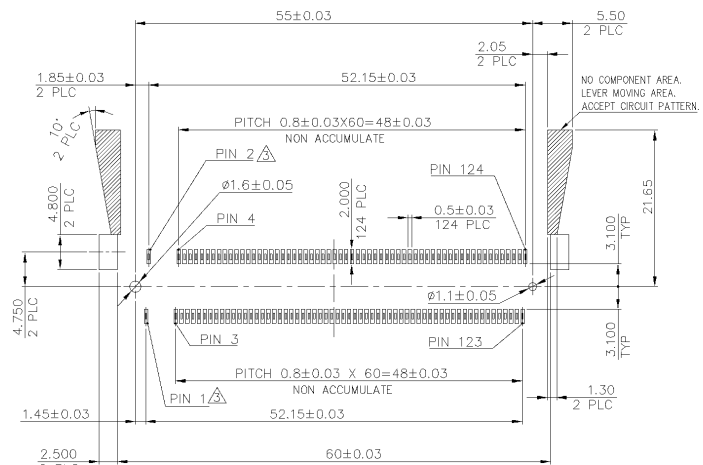
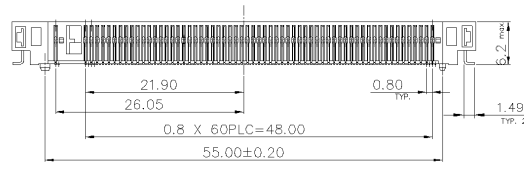
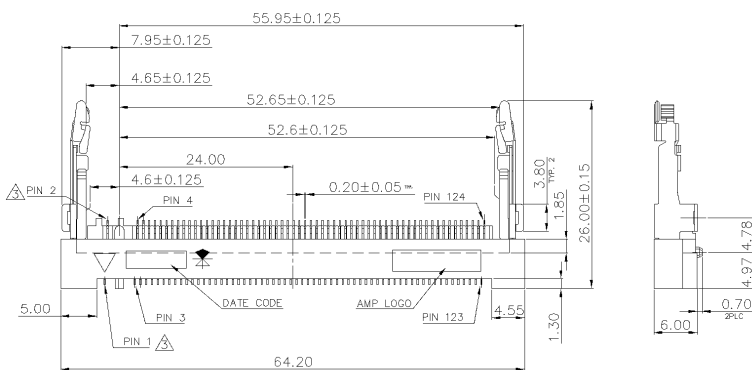
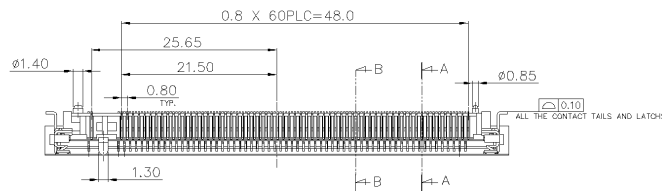

RECOMMENDED P.C.B. PATTERN LAYOUT  
(CONNECTOR MOUNTING SIDE)

- NOTE:
- MATERIAL:  
HOUSING: HIGH TEMP. THERMOPLASTIC 30% GF, UL 94V-0, COLOR: BLACK.  
CONTACTS: PHOSPHOR BRONZE.  
LATCHES: STAINLESS STEEL.
  - FINISH:  
CONTACTS: 5µ" MIN. GOLD PLATED IN CONTACT AREA, 50µ" MIN. NICKEL UNDERPLATED ALL OVER, 100µ" MIN. TIN(MATTE) OVER 50µ" MIN. NICKEL ON SOLDERTAIL.  
LATCHES: 80µ"~240µ" TIN(MATTE) OVER 50µ" MIN. NICKEL UNDERPLATING.
- ⚠ LACK OF PIN NO. 1 & 2

TAPE REEL	1-1734027-3
TAPE REEL	1734027-3
HARD TRAY	1734027-1
PACKAGE TYPE	PART NUMBER

TOLERANCES UNLESS OTHERWISE SPECIFIED: 0 PLC ± 0.25 1 PLC ± 0.15 2 PLC ± 0.1 3 PLC ± 0.05 ANGLES ± 2°	DWN	S. HOU 03-SEP-2004	<b>tyco</b> Electronics NAME TYCO HOLDINGS (BERMUDA) VII LTD. TAIWAN BRANCH
	CHK	W.J. KE 03-SEP-2004	
MATERIAL	APVD	W.J. KE 03-SEP-2004	0.8 PITCH MINI PCI SOCKET, 6.0 HEIGHT, 124 POSITION
SEE NOTE	PRODUCT SPEC	108-57437	
FINISH	APPLICATION SPEC	-	LOC DW A3
SEE NOTE	WEIGHT	5.1 GRAM	SCALE -- SHEET 1 OF 6

B	ADD P/N:1-3	F200-0205-04	SH	03SEP WK 2004
A	ADD P/N:-3	F200-0178-04	SH	13AUG WK 2004
C	FIRST RELEASED	F200-0250-03	JC	21OCT JW 2003
LTR	REVISION RECORD	ECN	SHW CHK	DATE

CUSTOMER DRAWING

NUMBER  
C-1734027



METRIC

THIS INFORMATION IS CONFIDENTIAL AND IS DISCLOSED TO YOU ON CONDITION THAT NO FURTHER DISCLOSURE IS MADE BY YOU TO OTHER THAN AMP PERSONNEL WITHOUT DIMENSIONS IN MILLIMETERS. DO NOT SCALE PRINT.

PRINT DIST  
DW

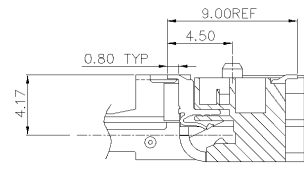
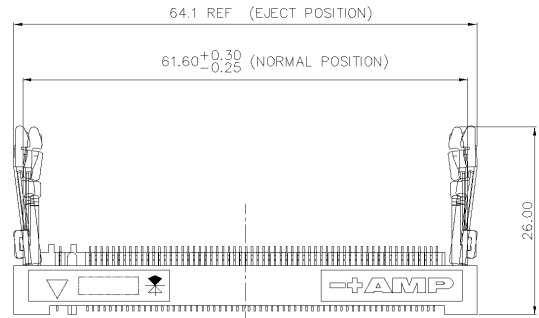

SEC A-A  
SCALE 2:1

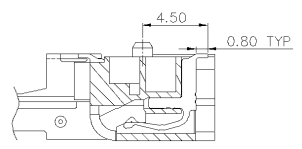

SEC B-B  
SCALE 2:1

SEE SHEET 1.	ECN	DATE
LTR	REVISION RECORD	DATE

TOLERANCES UNLESS OTHERWISE SPECIFIED: 0 PLC ± 0.25 1 PLC ± 0.15 2 PLC ± 0.1 3 PLC ± 0.05 ANGLES ± 2°	DWN S. HOU 03-SEP-2004	TYCO HOLDINGS (BERMUDA) VII LTD. TAIWAN BRANCH NAME 0.8 PITCH MINI PCI SOCKET, 6.0 HEIGHT, 124 POSITION
MATERIAL -	CHK W.J. KE 03-SEP-2004	
FINISH -	APVD W.J. KE 03-SEP-2004	LOC DW SCALE A <sub>3</sub>
	WEIGHT	DRAWING NO C-1734027
		REV B
		SHEET 2 OF 6

CUSTOMER DRAWING

NUMBER  
C-1734027

METRIC  
3RD ANGLE PROJECTION

THIS INFORMATION IS CONFIDENTIAL AND IS DISCLOSED TO YOU ON CONDITION THAT NO FURTHER DISCLOSURE IS MADE BY YOU TO OTHER THAN AMP PERSONNEL WITHOUT DIMENSIONS IN MILLIMETERS. DO NOT SCALE PRINT.

PRINT DIST  
DW

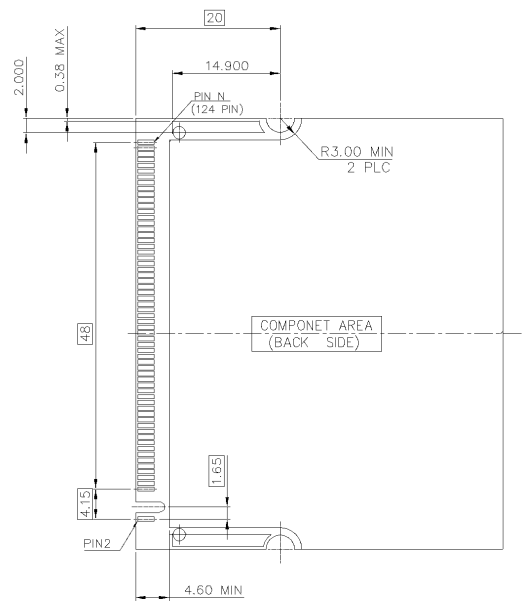
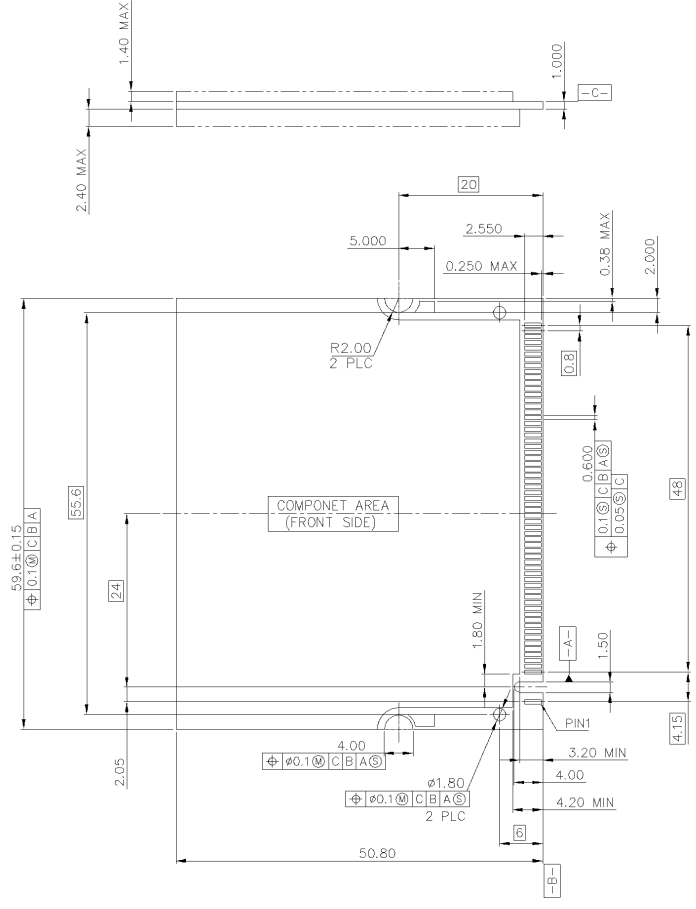

TOLERANCES UNLESS OTHERWISE SPECIFIED: 0 PLC ± 0.25 1 PLC ± 0.15 2 PLC ± 0.1 3 PLC ± 0.05 ANGLES ± 2°	DWN	S. HOU	<b>tyco</b> TYCO HOLDINGS (BERMUDA) VII LTD. TAIWAN BRANCH
	CHK	W.J. KE	
MATERIAL	APVD	W.J. KE	NAME 0.8 PITCH MINI PCI SOCKET, 6.0 HEIGHT, 124 POSITION
	PRODUCT SPEC	03-SEP-2004	
FINISH	APPLICATION SPEC		LOC
	WEIGHT		SIZE
			DRAWING NO
			SCALE
			REV
			SHEET

SEE SHEET 1.	ECN	PIN	DATE
REVISION RECORD		CHK	

CUSTOMER DRAWING

8 7 6 5 4 3 2 1

D  
C  
B  
A

NUMBER C-1734027  
 METRIC  
 3RD ANGLE PROJECTION

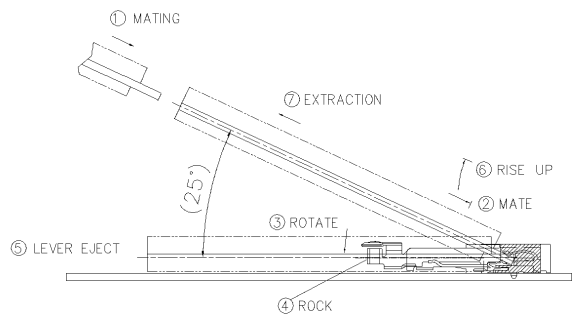
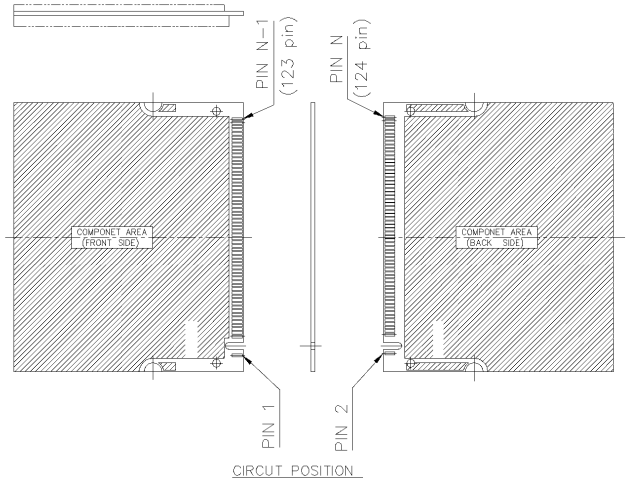
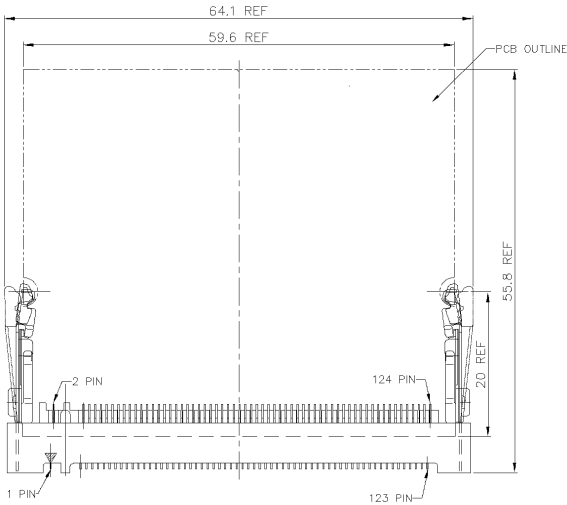

HOW TO MATE AND UNMATE  
 MATE: ① ~ ④  
 UNMATE: ⑤ ~ ⑦

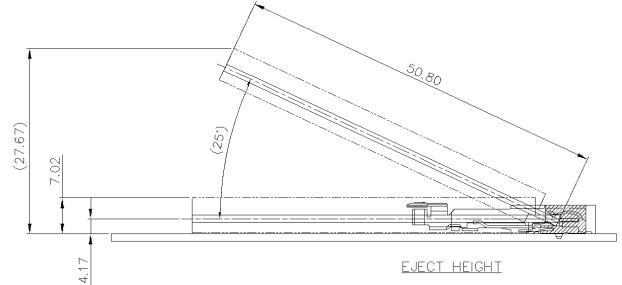

TOLERANCES UNLESS OTHERWISE SPECIFIED: 0 PLC ± 0.25 1 PLC ± 0.15 2 PLC ± 0.1 3 PLC ± 0.05 ANGLES ± 2°		DWN S. HOU 03-SEP-2004	<b>tyco</b> Electronics TYCO HOLDINGS (BERMUDA) VII LTD. TAIWAN BRANCH
MATERIAL		CHK W.J. KE 03-SEP-2004	
FINISH		APVD W.J. KE 03-SEP-2004	NAME 0.8 PITCH MINI PCI SOCKET, 6.0 HEIGHT, 124 POSITION
WEIGHT		APPLICATION SPEC	LOC SIZE DRAWING NO DW A <sub>3</sub> C-1734027
LTR		REVISION RECORD	SCALE SHEET -- 4 OF 6

THIS INFORMATION IS CONFIDENTIAL AND IS DISCLOSED TO YOU ON CONDITION THAT  
 NO PART HEREOF IS TO BE REPRODUCED OR DISCLOSED TO ANY OTHER PERSONNEL WITHOUT  
 THE WRITTEN PERMISSION OF TYCO ELECTRONICS. DIMENSIONS IN MILLIMETERS. DO NOT SCALE PRINT.

PRINT DIST  
 DW

8	7	6	5	4	3	2	1

CUSTOMER DRAWING

NUMBER C-1734027  
 METRIC  
 3RD ANGLE PROJECTION

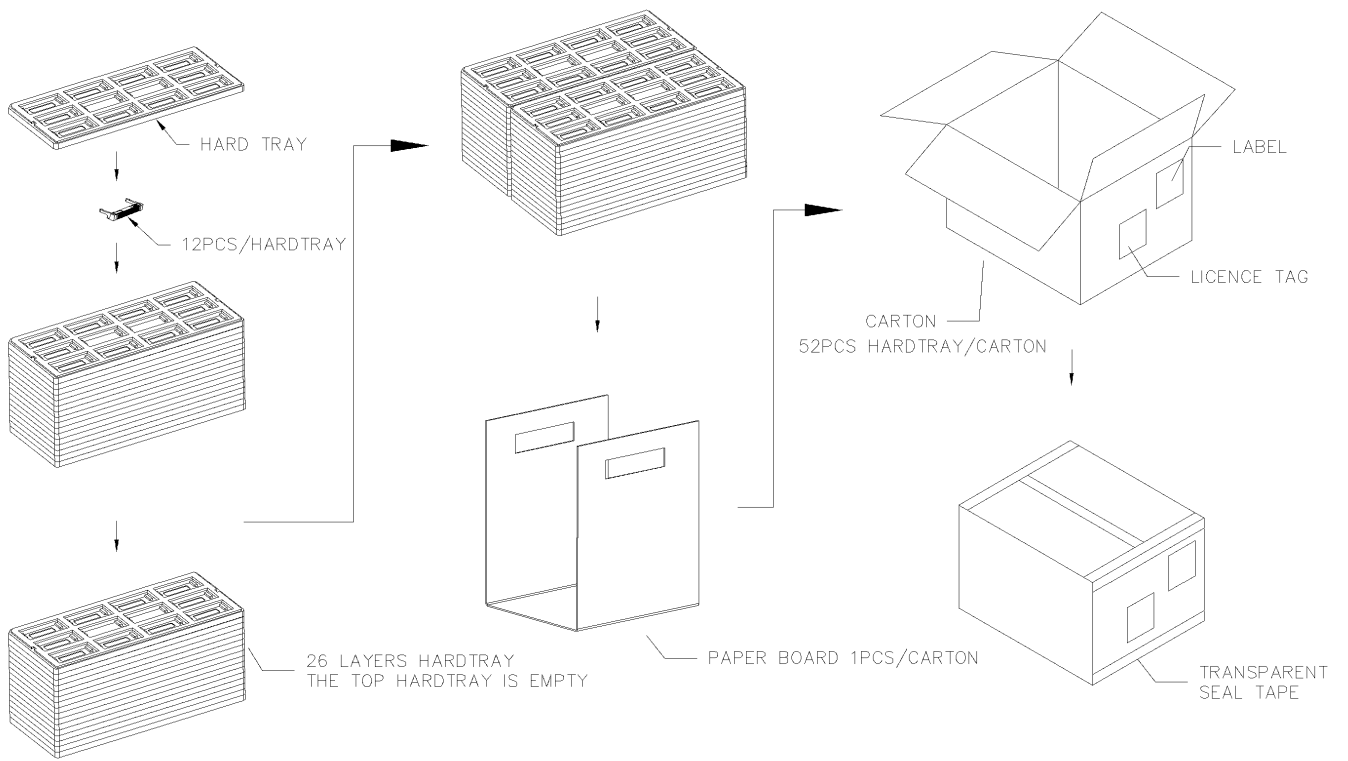

THIS INFORMATION IS CONFIDENTIAL AND IS DISCLOSED TO YOU ON CONDITION THAT NO PART THEREOF IS TO BE REPRODUCED OR DISCLOSED TO OTHER THAN AMP PERSONNEL WITHOUT DIMENSIONS IN MILLIMETERS. DO NOT SCALE PRINT.

8.8KG/CARTON	350X305X294	600 PCS
GROSS WEIGHT	CARTON SIZE	QTY/CARTON

TOLERANCES UNLESS OTHERWISE SPECIFIED: 0 PLC ± 1 PLC ± 2 PLC ± 3 PLC ± ANGLES ±	DWN S. HOU 03-SEP-2004	<b>tyco</b> <b>Electronics</b> NAME TYCO HOLDINGS (BERMUDA) VII LTD. TAIWAN BRANCH
	CHK W.J. KE 03-SEP-2004	
MATERIAL	APVD W.J. KE 03-SEP-2004	0.8 PITCH MINI PCI SOCKET, 6.0 HEIGHT, 124 POSITION.
FINISH	APPLICATION SPEC	LOC SIZE DRAWING NO DW A <sub>3</sub> C-1734027
	WEIGHT	SCALE SHEET -- 5 OF 6

SEE SHEET 1.	ECN	DATE
LTR	REVISION RECORD	DATE

8 7 6 5 4 3 2 1 CUSTOMER DRAWING

NUMBER C-1470459  
 METRIC  
 3RD ANGLE PROJECTION

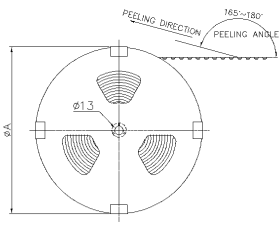
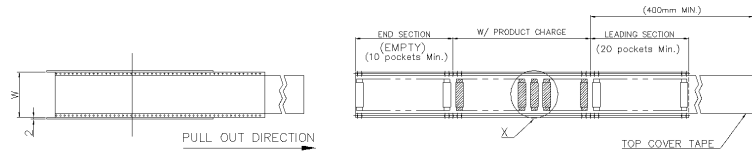

- NOTES:
- MATERIAL :
    - EMBOSSSED CARRIER: PS
    - COVER TAPE: PS
    - SHIPPING CARTON: CORRUGATED FIBER
  - DIMENSION :
    - REEL: W=89.4, øA=330
    - SHIPPING CARTON: L=335, W=335, H=345
  - QUANTITY :
    - PRIMARY PACKING: 200PCS/REEL
    - SECONDARY PACKING: 3 REELS/CARTON(600PCS)
  - WEIGHT :
    - NET WEIGHT: 1.02Kg/REEL, 3.06Kg/CARTON.
    - GROSS WEIGHT: 1.51Kg/REEL, 5.98Kg/CARTON.
  - PEELING RESISTANCE: 0.1~0.7N(10.2gf~71.4gf).
  - PEELING SPEED: 300mm/minutes.

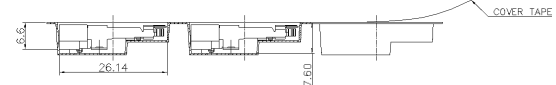
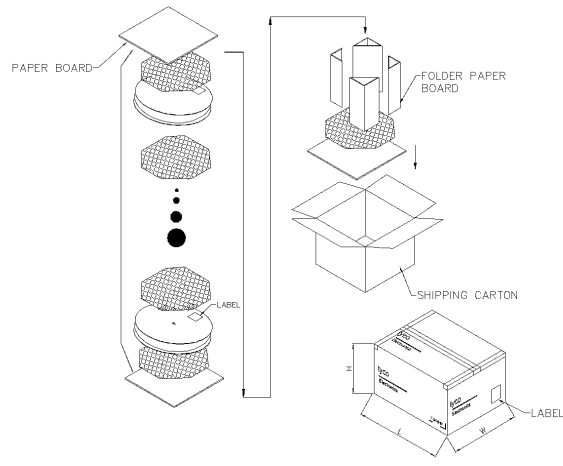
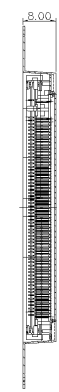
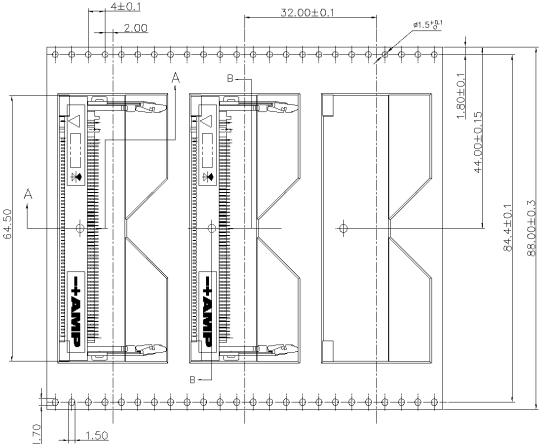

THIS INFORMATION IS CONFIDENTIAL AND IS DISCLOSED TO YOU ON CONDITION THAT NO PART HEREOF IS TO BE REPRODUCED OR DISCLOSED TO OTHER THAN AMP PERSONNEL WITHOUT THE WRITTEN PERMISSION OF AMP. DIMENSIONS IN MILLIMETERS. DO NOT SCALE PRINT.

PRINT DIST DW

TOLERANCES UNLESS OTHERWISE SPECIFIED: 0 PLC ± 1 PLC ± 0.15 2 PLC ± 0.10 3 PLC ± 0.05 ANGLES ±2°	DWN S. HOU 03-SEP-2004	<b>tyco</b> Electronics NAME TYCO HOLDINGS (BERMUDA) VII LTD. TAIWAN BRANCH
	CHK W.J. KE 03-SEP-2004	
MATERIAL	APVD W.J. KE 03-SEP-2004	0.8 PITCH MINI PCI SOCKET, 6.0 HEIGHT, 124 POSITION.
FINISH	APPLICATION SPEC	LOC SIZE DRAWING NO DW A3 C-1734027
WEIGHT	WEIGHT	SCALE SHEET -- 6 OF 6

SEE SHEET 1.	ECN	DWN/CHK	DATE
LTR	REVISION RECORD	ECN	DWN/CHK

8 7 6 5 4 3 2 1  
 CUSTOMER DRAWING