

THIS DRAWING IS UNPUBLISHED. RELEASED FOR PUBLICATION
 © COPYRIGHT BY TYCO ELECTRONICS CORPORATION. ALL RIGHTS RESERVED.

REVISIONS					
P	LTR	DESCRIPTION	DATE	DWN	APVD
0		RELEASED FJBO-1113-04	25AUG2004	J.Z	I.E

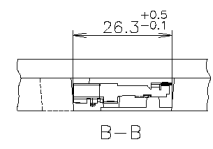
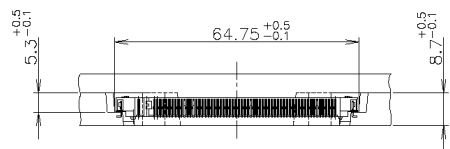
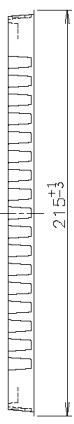
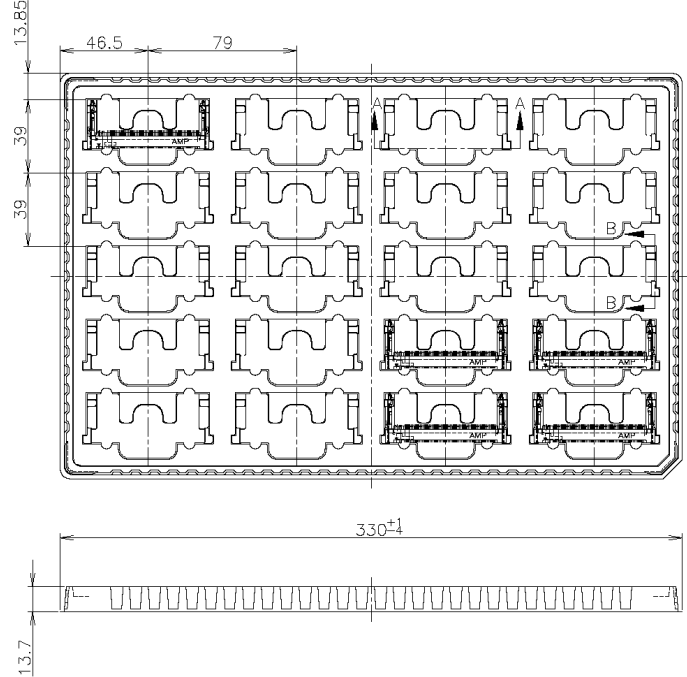

1. THE DIRECTION OF EACH CONNECTOR ON A TRAY IS REFERRED TO THIS DWG.
2. REFER TO PACKING SPEC 107-5195-1
3. GENERAL TOLERANCES ±0.5

LEAD FREE

THIS DRAWING IS A CONTROLLED DOCUMENT.		DWN Julyee Zhu 25AUG2004	20EA/TRAY		7-912077-3	6565283-1
DIMENSIONS: MM		CHK Steven Yao 25AUG2004	QTY		TRAY P/N	PART NUMBER
TOLERANCES UNLESS OTHERWISE SPECIFIED:		APVD Ikuo Enomoto 25AUG2004	Tyco Electronics AMP K.K. Kawasaki Japan			
0 PLC ±		NAME				
1 PLC ±		108-60040				
2 PLC ±		SEMI-HARD TRAY ASSY				
3 PLC ±		0.8mm PITCH FAX MODEM SOCKET 124 POSITIONS				
4 PLC ±		5.2mm HEIGHT				
ANGLES ±		SIZE		CAGE CODE	DRAWING NO	RESTRICTED TO
MATERIAL		A3		00779	6565283	
FINISH		WEIGHT		CUSTOMER DRAWING		
		SCALE		NTS	SHEET	1 OF 5
		REV		0		

4

3

2

1

THIS DRAWING IS UNPUBLISHED. RELEASED FOR PUBLICATION
 COPYRIGHT BY TYCO ELECTRONICS CORPORATION. ALL RIGHTS RESERVED.

LOC		DIST		REVISIONS			
P	LTR	DESCRIPTION	DATE	DWN	APVD		
-	-	SEE SHEET 1	-	-	-		

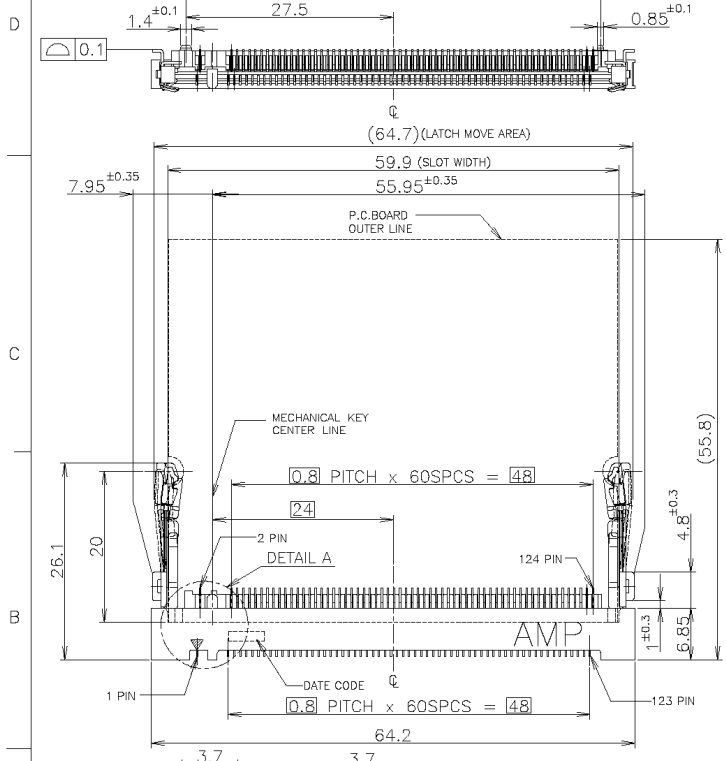

- MATERIAL; HOUSING: HIGH TEMPERATURE THERMO PLASTIC UL94V-0
 COLOR: BLACK
 CONTACT: PHOS-BRZ
 LOCK LEVER: SUS TIN PLATING.
 - FINISH; CONTACT AREA: GOLD FLASH ON 0.0013MIN ALL OVER NICKEL.
 SOLDERING AREA: GOLD FLASH.
- 3 TOLERANCES NON CUMMURATIVE.

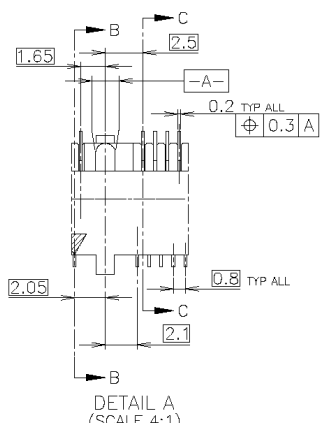

LEAD FREE

5.2	6565283-1
HEIGHT	P/N

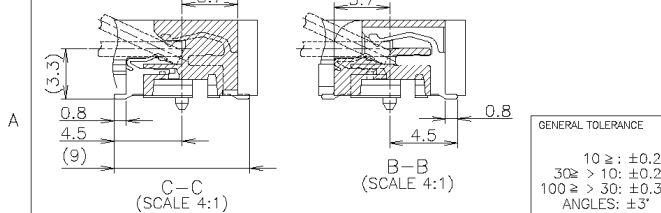

THIS DRAWING IS A CONTROLLED DOCUMENT.		DWN Julyee Zhu	25AUG2004	tyco Electronics	Tyco Electronics AMP K.K.	
DIMENSIONS: MM		CHK Steven Yao	25AUG2004		Kawasaki Japan	
TOLERANCES UNLESS OTHERWISE SPECIFIED:		APVD Ikuo Yamoto	25AUG2004	NAME	0.8MM PITCH FAXMODEM SOCKET	
0 PLC ±		PRODUCT SPEC		124POSITIONS		
1 PLC ±		APPLICATION SPEC		5.2MM HEIGHT		
2 PLC ±		WEIGHT		SIZE	CAGE CODE	DRAWING NO
3 PLC ±				A3	00779	C=6565283
4 PLC ±		CUSTOMER DRAWING		SCALE	2:1	SHEET 2 OF 5
ANGLES: ±3'				REV		0

GENERAL TOLERANCE
 10 ≥ : ±0.2
 30 ≥ > 10: ±0.25
 100 ≥ > 30: ±0.3
 ANGLES: ±3'

AMP 1470-19 REV 31MAR2000

FB001310

D:\WorkFile\Download_File\B057709\1565283\C-6565284_0.dwg

THIS DRAWING IS UNPUBLISHED. RELEASED FOR PUBLICATION
 COPYRIGHT BY TYCO ELECTRONICS CORPORATION. ALL RIGHTS RESERVED.

LOC		DIST		REVISIONS			
P	LTR	DESCRIPTION	DATE	DN	APVD		
SEE SHEET 1							

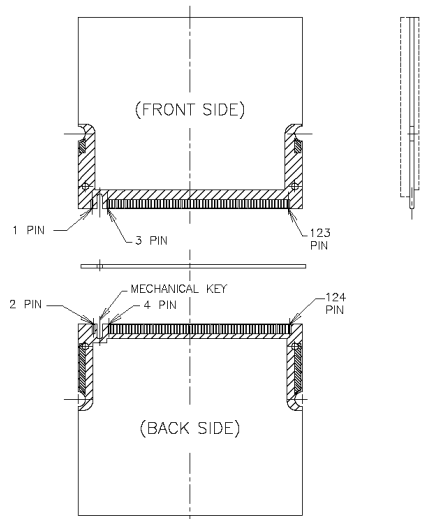

CIRCUIT POSITION
(SCALE 1:1)

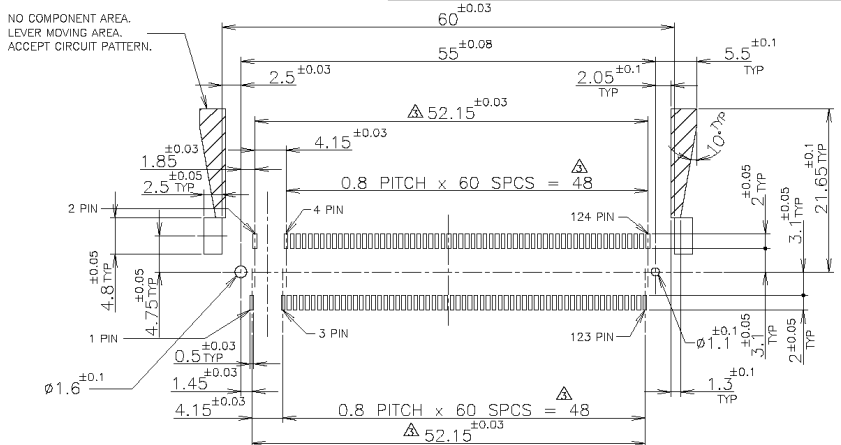

LEAD FREE

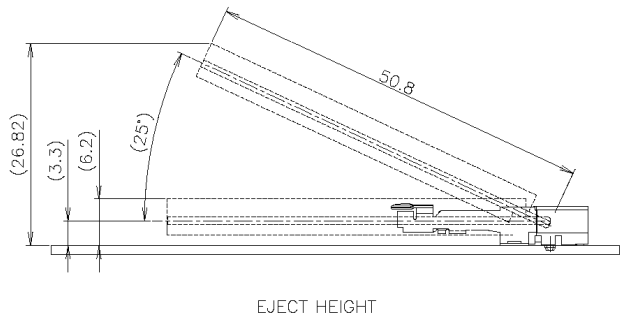
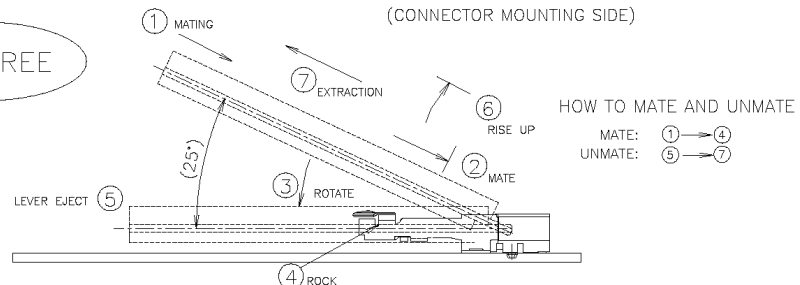

THIS DRAWING IS A CONTROLLED DOCUMENT.		DIN	Tyco Electronics AMP K.K. Kawasaki, Japan	
DIMENSIONS: MM		CIK	NAME	
TOLERANCES UNLESS OTHERWISE SPECIFIED:		APVD	0.8MM PITCH FAXMODEM SOCKET	
0 PLC	±	PRODUCT SPEC	124 POSITIONS	
1 PLC	±	APPLICATION SPEC	5.2MM HEIGHT	
2 PLC	±	WEIGHT	SIZE	CAGE CODE
3 PLC	±		A3	00779
4 PLC	±		DRAWING NO	C=6565283
ANGLES	±	CUSTOMER DRAWING	SCALE	2:1
MATERIAL	FINISH		SHEET	3 OF 5
			REV	0

THIS DRAWING IS UNPUBLISHED. RELEASED FOR PUBLICATION
 © COPYRIGHT BY TYCO ELECTRONICS CORPORATION. ALL RIGHTS RESERVED.

LOC		DIST		REVISIONS			
P	LTR	DESCRIPTION		DATE	DN	APVD	
SEE SHEET 1							

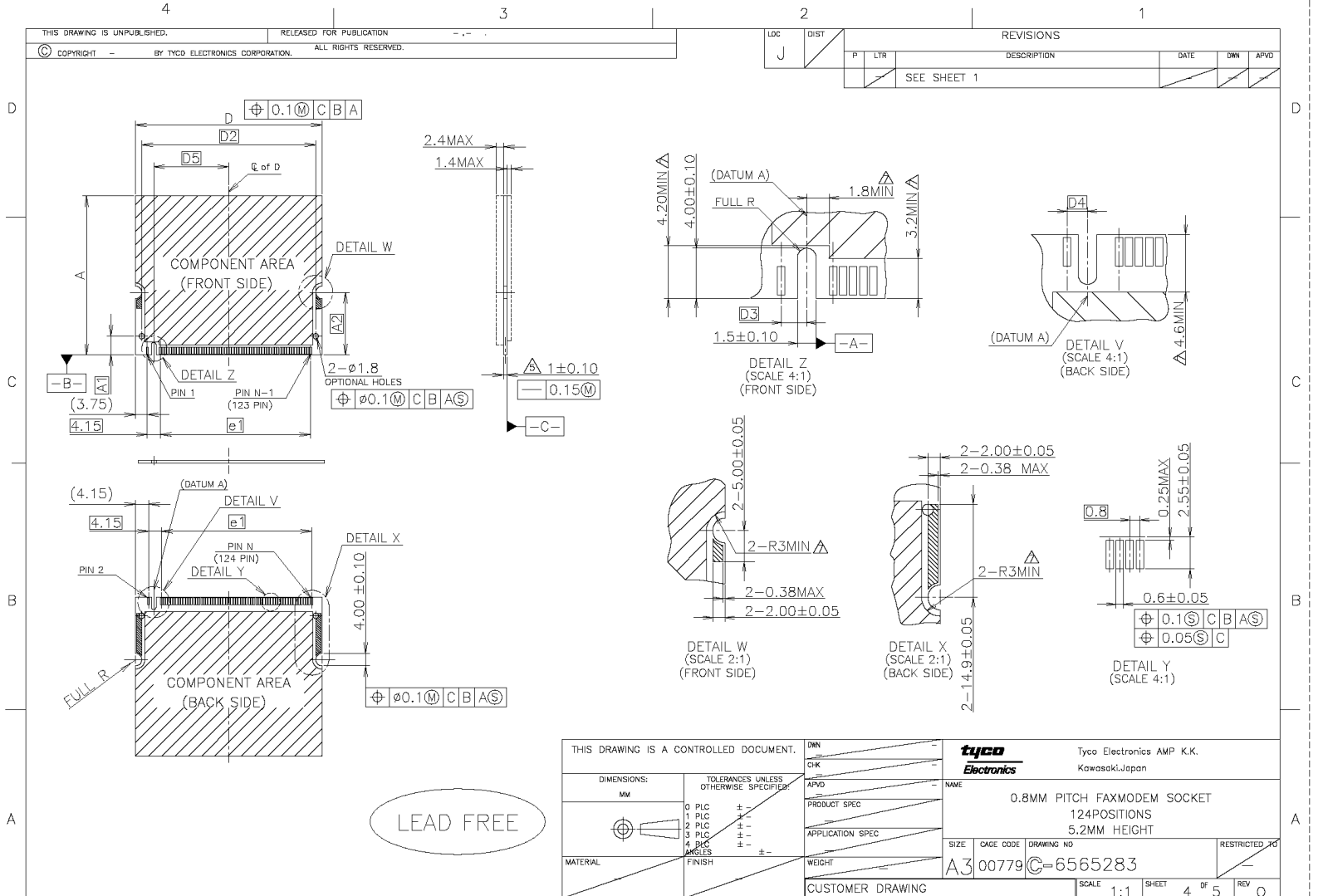

LEAD FREE

THIS DRAWING IS A CONTROLLED DOCUMENT.		DIN	tyco Tyco Electronics AMP K.K. Kawasaki, Japan	
DIMENSIONS: MM	TOLERANCES UNLESS OTHERWISE SPECIFIED:	CIK	NAME	
0 PLC ±	1 PLC ±	APVD	0.8MM PITCH FAXMODEM SOCKET	
2 PLC ±	3 PLC ±	PRODUCT SPEC	124 POSITIONS	
4 PLC ±	ANGLES ±	APPLICATION SPEC	5.2MM HEIGHT	
MATERIAL	FINISH	WEIGHT	SIZE: A3	CAGE CODE: 00779
			DRAWING NO: C=6565283	RESTRICTED TO
CUSTOMER DRAWING			SCALE: 1:1	SHEET 4 OF 5

AMP 1470-19 REV 31MAR2000
 FB001310

THIS DRAWING IS UNPUBLISHED. RELEASED FOR PUBLICATION
 COPYRIGHT BY TYCO ELECTRONICS CORPORATION. ALL RIGHTS RESERVED.

LOC		DIST		REVISIONS			
P	LTR	DESCRIPTION	DATE	DWN	APVD		
J				SEE SHEET 1			

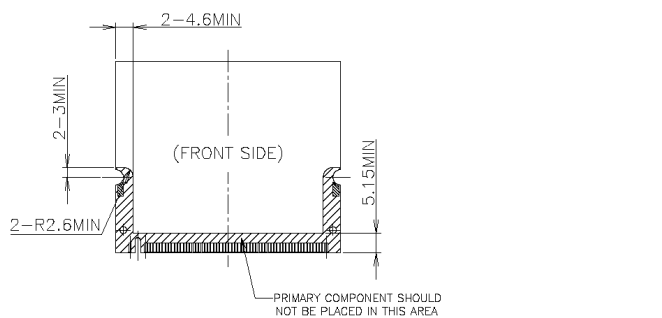

- 4 TOLERANCES ON ALL DIMENSIONS ± 0.15 UNLESS OTHERWISE SPECIFIED.
- 5 CARD THICKNESS APPLIES ACROSS TABS AND INCLUDES PLATING AND/OR METALIZATION.
- 6 APPLICATION NOTE:
 GOLD CONTACT PAD: ELECTROLESS GOLD PLATING 0.0577m MIN.
 BORDER OF COMPONENT AREA.

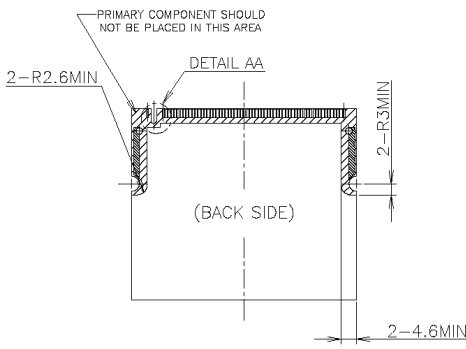
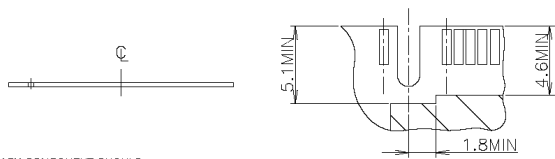

SYMBOL	VARIATIONS ALL DIMENSIONS IN mm					
	NORMAL HEIGHT 44.45			NORMAL HEIGHT 50.80		
	AA			BA		
	MIN	NOM	MAX	MIN	NOM	MAX
A	44.30	44.45	44.60	50.65	50.80	50.95
A1	6.00 BSC			6.00 BSC		
A2	20.00 BSC			20.00 BSC		
D	59.45	59.60	59.75	59.45	59.60	59.75
D2	55.60 BSC			55.60 BSC		
D3	2.05 BSC			2.05 BSC		
D4	1.65 BSC			1.65 BSC		
D5	24.00 BSC			24.00 BSC		
e1	48.00 BSC			48.00 BSC		
N	124			124		

LEAD FREE

THIS DRAWING IS A CONTROLLED DOCUMENT.		DWN		Tyco Electronics AMP K.K.	
DIMENSIONS: MM		CIK		Kawasaki, Japan	
TOLERANCES UNLESS OTHERWISE SPECIFIED:		APVD		NAME	
0 PLC \pm		PRODUCT SPEC		0.8MM PITCH FAXMODEM SOCKET	
1 PLC \pm		APPLICATION SPEC		124 POSITIONS	
2 PLC \pm		WEIGHT		5.2MM HEIGHT	
3 PLC \pm		CUSTOMER DRAWING		SIZE: A3	
4 PLC \pm		SCALE: 1:1		CAGE CODE: 00779	
ANGLES \pm		SHEET: 5 OF 5		DRAWING NO: C-6565283	
MATERIAL		REV: 0		RESTRICTED TO	