



PRODUCT SPECIFICATION

Reverse Right Angle Mini DIMM, 200 / 244 Ckt 0.60mm pitch SMT

1.0 SCOPE

This Product Specification covers the performance requirements of the 0.60 mm centerline edge card socket for board to board interconnect of 1.00 mm thick memory modules.

2.0 PRODUCT DESCRIPTION

2.1 PRODUCT NAME AND SERIES NUMBER (S)

Series Number
78001

Product Descriptions
200/244 Ckt Reverse Right Angle Mini DIMM

2.2 DIMENSIONS, MATERIALS, PLATINGS AND MARKINGS

See the appropriate Sales Drawings for information on dimensions, materials, plating and markings, recommended module outlines and footprint Specifications.

2.3 SAFETY AGENCY APPROVALS

UL File : E29179
CSA File : 1699020 (LR 19980)

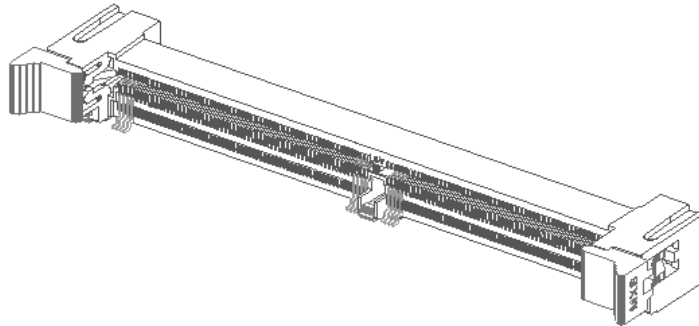

REVISION: B	ECR/ECN INFORMATION: EC No: S2007-1019 DATE: 2007/05/17	TITLE: Reverse Right Angle Mini DIMM, SMT Connector 200/244Ckt, 0.60mm Pitch	SHEET No. 1 of 6
DOCUMENT NUMBER: PS-78001-001	CREATED / REVISED BY: CM TEO 2007/05/17	CHECKED BY: YT YANG 2007/05/25	APPROVED BY: SH LENI 2007/05/25

TEMPLATE FILENAME: PRODUCT_SPEC(SIZE_A4)(V.1).DOC



PRODUCT SPECIFICATION

3.0 APPLICABLE DOCUMENTS AND SPECIFICATIONS

The following documents are part of this specification between the requirements of this specified herewith. In the event of conflict between the requirements of this specification and the product drawings, the product drawings shall take precedence. In the event of conflict between the requirements of this specification and reference documents, this specification shall take precedence.

4.0 RATINGS

4.1 VOLTAGE

30 VRMS at 60 Hz

4.2 CURRENT

1.0 Amps at 30°C Temperature Rise

4.3 TEMPERATURE

Operating Temperature: -55°C to +85°C

5.0 PERFORMANCE

5.1 ELECTRICAL REQUIREMENTS

ITEM	DESCRIPTION	TEST CONDITION	REQUIREMENT
1	Contact Resistance (Low Level)	Mate connectors: apply a maximum voltage of 20 mV and a current of 100 mA. EIA-364-23	50 mΩ maximum at initial 10 mΩ maximum change from initial
2	Temperature Rise at rated current	Temperature of mater connector at rated current for 96 hours (6 consecutive ckts link in series)	1.0 Amps per contact at a maximum of 30°C temperature rise
3	Insulation Resistance	Unmate & unmount connectors: apply a voltage of 500 VDC between adjacent terminals and between terminals to ground. EIA-364-21	1000 Mega Ω minimum
4	Dielectric Withstanding Voltage	Apply 500 VAC for 1 minute between adjacent terminals of an unmated connector. EIA-364-20	No breakdown or flashover

REVISION: B	ECR/ECN INFORMATION: EC No: S2007-1019 DATE: 2007/05/17	TITLE: Reverse Right Angle Mini DIMM, SMT Connector 200/244Ckt, 0.60mm Pitch	SHEET No. 2 of 6
DOCUMENT NUMBER: PS-78001-001	CREATED / REVISED BY: CM TEO 2007/05/17	CHECKED BY: YT YANG 2007/05/25	APPROVED BY: SH LENI 2007/05/25

TEMPLATE FILENAME: PRODUCT_SPEC[SIZE_A4](V.1).DOC



PRODUCT SPECIFICATION

5.2 MECHANICAL REQUIREMENTS

ITEM	DESCRIPTION	TEST CONDITION	REQUIREMENT
5	Vibration	Amplitude : 1.52mm peak to peak Sweep : 10-55-10 Hz in one min. Duration : 2 hrs each on XYZ axis Module weight: 15g for 244Ckt and 13g for 200Ckt. EIA 364-28	No change in LLCR greater than 10mΩ from initial. Discontinuity : No greater than 1.0 micro sec.
6	Shock (Mechanical)	Mate connectors and shock at 30 g's with half-sine waveform for 11 milliseconds, 3 shocks in each perpendicular axis (18 shocks total). Module weighted : 15g for 244Ckt and 13g for 200Ckt.	No change in LLCR greater than 10mΩ from initial. Discontinuity : No greater than 1.0 micro sec.
7	Durability	Mate and unmated connectors up to 25 cycles at a maximum rate of 10 cycles per minute. Reseating to be done for 3 cycles.	No change in LLCR greater than 10 mΩ from initial.
8	Module Insertion Force (w/ Latches)	Insert a 1.00 mm thick Module(0.10x0.10 mm chamfer) at a rate of 25 ± 6mm (1 ± ¼ inch) per minute. See Sales drawing for PCB/ Module details.	Total insertion force not to exceed : 195.0 N (43.73lbs) for 200 ckt 238.0 N (53.37lbs) for 244 ckt
9	Module Rip Out Force	Apply a pulling force on module card at a rate of 25 ± 6 mm/min. (1 ± ¼ inch) with recommended test module as per sales drawing, inserted into connector with latches closed.	35.0 N (7.85lbs) min. retention force of the module in connector with no damage
10	Latch Actuation Force	Apply an actuation force on each latch at a rate of 25 ± 6 mm/ min (1 ± ¼ inch) with recommended test module as per sales drawing inserted into connector.	The force to fully actuate the latch open shall be 35 N (7.85 lbs) max. per latch.
11	Latch Overstress Force	Apply an actuation force on each latch at a rate of 25 ± 6 mm / min (1 ± ¼ inch) in the fully open position.	35 N (7.85 lbs) min force with no damage.
12	Terminal Retention Force	Axial pullout force on the terminal in the housing at a rate of 25 ± 6 mm (1 ± ¼ inch) per minute.	3 N minimum

REVISION: B	ECR/ECN INFORMATION: EC No: S2007-1019 DATE: 2007/05/17	TITLE: Reverse Right Angle Mini DIMM, SMT Connector 200/244Ckt, 0.60mm Pitch	SHEET No. 3 of 6
DOCUMENT NUMBER: PS-78001-001	CREATED / REVISED BY: CM TEO 2007/05/17	CHECKED BY: YT YANG 2007/05/25	APPROVED BY: SH LENI 2007/05/25

TEMPLATE FILENAME: PRODUCT_SPEC[SIZE_A4](V.1).DOC



PRODUCT SPECIFICATION

5.3 ENVIRONMENTAL REQUIREMENTS

ITEM	DESCRIPTION	TEST CONDITION	REQUIREMENT										
13	Shock (Thermal)	Mate connectors; expose to 5 cycles of: <table border="1"> <thead> <tr> <th>Temperature °C</th> <th>Duration (Minutes)</th> </tr> </thead> <tbody> <tr> <td>-55 +0/-3</td> <td>30</td> </tr> <tr> <td>+25 +10/-5</td> <td>5 MAXIMUM</td> </tr> <tr> <td>+85 +3/-0</td> <td>30</td> </tr> <tr> <td>+25 +10/-5</td> <td>5 MAXIMUM</td> </tr> </tbody> </table> EIA-364-32-Test condition I	Temperature °C	Duration (Minutes)	-55 +0/-3	30	+25 +10/-5	5 MAXIMUM	+85 +3/-0	30	+25 +10/-5	5 MAXIMUM	No change in LLCR greater than 10 mΩ from initial.
Temperature °C	Duration (Minutes)												
-55 +0/-3	30												
+25 +10/-5	5 MAXIMUM												
+85 +3/-0	30												
+25 +10/-5	5 MAXIMUM												
14	Thermal Aging	Mate connectors and expose to 500 hours at 105 ± 2°C. Per EIA-364-17 Preconditioning to be done at 105°C for 72 hrs	No change in LLCR greater than 10 mΩ from initial.										
15	Cyclic Temperature & Humidity	Mate connectors and expose for 10 days at 25°C to 65°C at 90-98% RH. Per EIA-364-31, Method III.	No change in LLCR greater than 10 mΩ from initial.										
16	Solderability	Solder time: 5±0.5 seconds. Solder temperature: 260±5°C Subject to steam aging for 8 hours ± 5 mins.	Solder coverage: 95% minimum										
17	Porosity	Nitric Acid Test, 10 contacts per contact type selected at random. Per EIA 364-53	Maximum number of pores : 30uin-1 pore per 10 contacts										
18	Solvent Resistance	42 parts DI water by volume, 1 part of propylene glycol monomethyl ether (Glycolether PM, 1 methoxy-2-propanol). 1 part by volume of monoethanolamine. MIL – STD – 202F Method 215J.	No Damage or discoloration of connector materials or marking.										
19	Resistance to Soldering Heat Test	Unmated, exposed to reflow profile as defined in Section 8.1.	No Damage or blistering.										

REVISION: B	ECR/ECN INFORMATION: EC No: S2007-1019 DATE: 2007/05/17	TITLE: Reverse Right Angle Mini DIMM, SMT Connector 200/244Ckt, 0.60mm Pitch	SHEET No. 4 of 6
DOCUMENT NUMBER: PS-78001-001	CREATED / REVISED BY: CM TEO 2007/05/17	CHECKED BY: YT YANG 2007/05/25	APPROVED BY: SH LENI 2007/05/25

TEMPLATE FILENAME: PRODUCT_SPEC[SIZE_A4](V.1).DOC



PRODUCT SPECIFICATION

6.0 TEST SEQUENCE

Test Description Sequence	Test Group											
	1	2	3	4	5	6	7	8	9	10	11	12
Contact Resistance	1 3 5 7	9 1 3 5	1 4 6 8									
Temperature Rise											1	
Insulation Resistance				1 5								
Dielectric Withstand Voltage				2 6								
Vibration	6											
Mechanical Shock	8											
Durability (5X) pre-cond.	2											
Durability (25X)			2									
Module Insertion Force					1							
Module Ripout Force					2							
Latch Actuation Force												1
Latch Overstress Force												2
Thermal Shock			3	3								
Thermal Aging 105°C – 500hrs		2										
Cyclic Temp & Humidity			5	4								
Plating thickness						1						
Solderability								1				
Porosity									1			
Solvent Resistance							1					
Terminal Retention Force										1 3		
Resistance to Soldering Heat										2		
Temp life (pre-conditioning) 105°C – 72hrs	4											
Reseating (3X)		4	7									
Sample Size per Test Group	5	5	5	5	5	5	5	5	5	5	5	5

7.0 PACKAGING

Parts shall be packed in trays and protected against damage during handling, transportation and storage.

REVISION: B	ECR/ECN INFORMATION: EC No: S2007-1019 DATE: 2007/05/17	TITLE: Reverse Right Angle Mini DIMM, SMT Connector 200/244Ckt, 0.60mm Pitch	SHEET No. 5 of 6
DOCUMENT NUMBER: PS-78001-001	CREATED / REVISED BY: CM TEO 2007/05/17	CHECKED BY: YT YANG 2007/05/25	APPROVED BY: SH LENI 2007/05/25

TEMPLATE FILENAME: PRODUCT_SPEC(SIZE_A4)(V.1).DOC

8.0 OTHER INFORMATIONS

8.1 Reflow Profile.

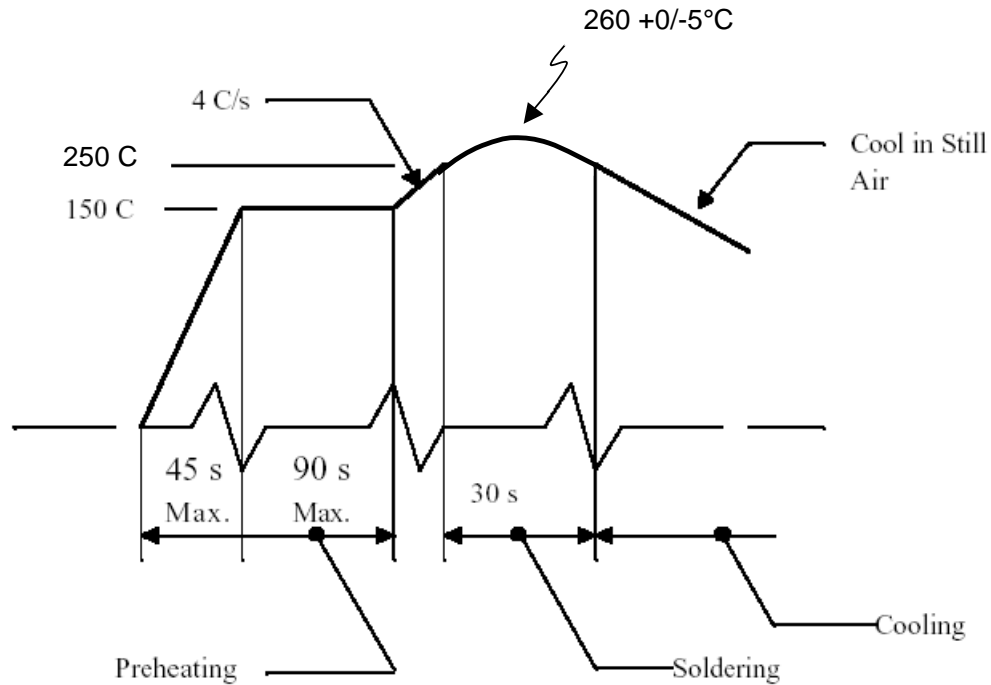

Notes :

1. Reflow solder Preheat at 3°C/s to 150°C.
2. Reflow at 250°C for 30s per figure.
3. Peak to be at 260 ± 0/-5°C.
4. Component must withstand (2) reflow solder cycles with a cool down between.

REVISION: B	ECR/ECN INFORMATION: EC No: S2007-1019 DATE: 2007/05/17	TITLE: Reverse Right Angle Mini DIMM, SMT Connector 200/244Ckt, 0.60mm Pitch	SHEET No. 6 of 6
DOCUMENT NUMBER: PS-78001-001	CREATED / REVISED BY: CM TEO 2007/05/17	CHECKED BY: YT YANG 2007/05/25	APPROVED BY: SH LENI 2007/05/25