

REVISED PER ECR-10-007858		DATE	BY	APP
1	REVISIONS			
1	DESCRIPTION			
2	REVISIONS			
3	DESCRIPTION			
4	REVISIONS			
5	DESCRIPTION			

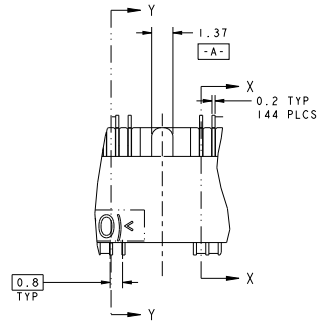

DETAIL B  
SCALE 8:1

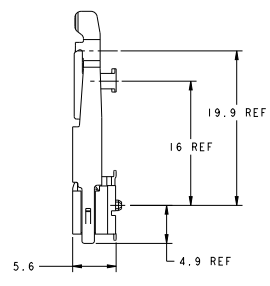
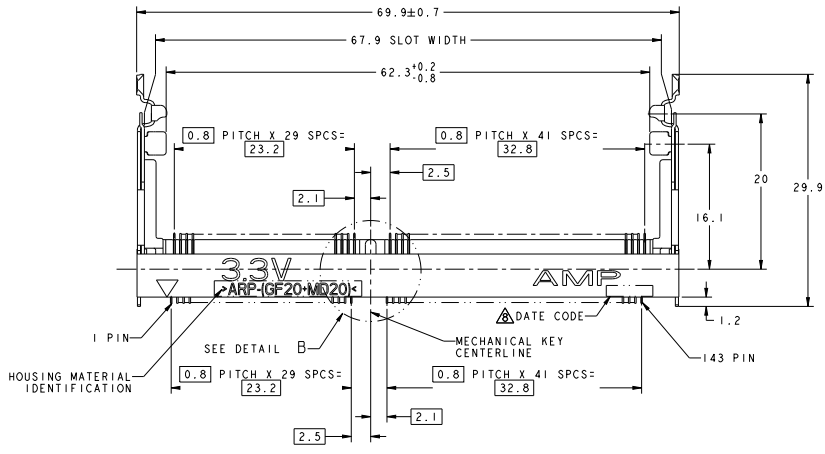
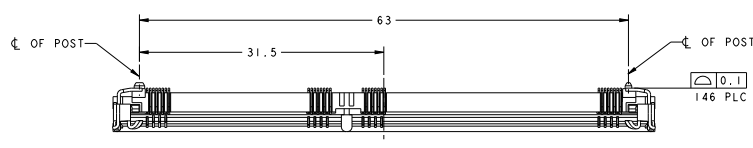
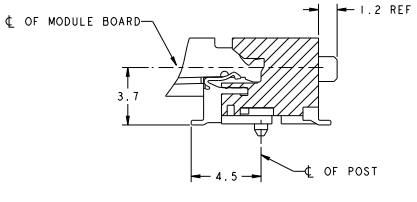

SECTION X-X  
ROTATED 90° CCW  
SCALE 8:1

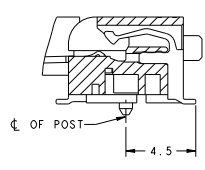

SECTION Y-Y  
ROTATED 90° CCW  
SCALE 8:1

- △ MATERIAL: HIGH TEMPERATURE PLASTIC, UL94V-0  
CONTACT: COPPER ALLOY  
LATCH: STAINLESS STEEL, TIN PLATING.
- △ FINISH: CONTACT AREA: 0.00025 MIN GOLD PLATE ON  
0.001 MIN ALL OVER NICKEL  
SOLDERING AREA: 0.00005 MIN TO 0.00030 MAX  
GOLD PLATE
- 3. TOLERANCES NON-ACCUMULATIVE.
- △ PACKAGED IN HARD TRAY.
- △ FINISH: CONTACT AREA: 0.00025 MIN GOLD PLATE ON  
0.001 MIN ALL OVER NICKEL  
SOLDERING AREA: BRIGHT TIN LEAD PLATE.
- △ PART PACKAGED PER EIA-18704 STANDARD. REEL  
DIAMETER SHALL BE 330mm, TAPE WIDTH SHALL BE  
88mm, AND TAPE PITCH SHALL BE 36mm.
- △ LATCH PLATING: TIN-LEAD FOR P/N: 8-390112-1 ONLY  
(IDENTICAL TO PREVIOUS P/N: 390112-1)
- △ DATE CODE (4-DIGITS), LOCATED AS SHOWN.  
TO BE INTERPRETED AS FOLLOWS:  
DIGIT # 1 - LAST DIGIT OF YEAR.  
DIGITS # 2 AND # 3 - CALENDAR WEEK.  
DIGIT # 4 - DAY OF THE WEEK  
(WITH SUNDAYS AS DAY 1).

SUPERSEDED BY	REMARKS	COLOR	FINISH	POS	PART NO.
NIL	AVAILABLE	NATURAL	△△	144	8-390112-1
NIL	AVAILABLE	BLACK	△	144	7-390112-1
NIL	AVAILABLE	NATURAL	△	144	6-390112-1
3-390112-1	NOT AVAILABLE	NATURAL	△	144	3-390112-4
NIL	AVAILABLE	NATURAL	△	144	3-390112-1
390112-1	NOT AVAILABLE	NATURAL	△	144	390112-4
NIL	AVAILABLE	NATURAL	△	144	390112-1

SYMBOL	DESCRIPTION	DATE	BY	APP
1	SEE TABLE	11-11-14		
2	CUSTOMER DRAWING	00779	390112	

REV	DATE	DESCRIPTION	BY	CHK
1		SEE SHEET 1		

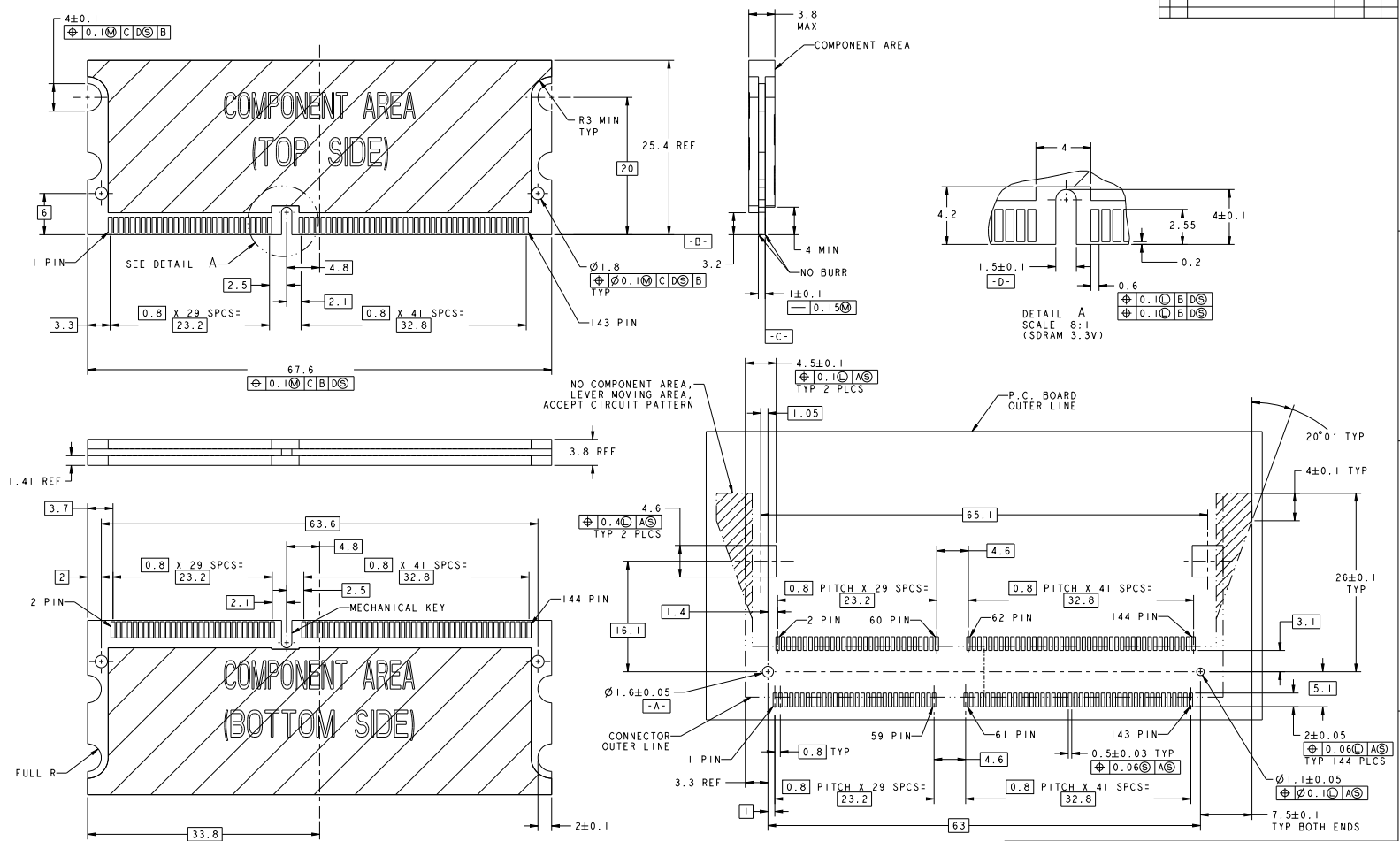

SINGAPORE 1118 INCORPORATED 1118-1114 TEL: 673-7272 FAX: 673-7273 WWW: 1118-1114	1118 ELECTRONICS SINGAPORE S.O. DIMM SOCKET ASSY. 0.8mm, 3.3V, 144 POSITION, HIGH PROFILE FOR SDRAM TYPE MODULE	DRAWING NO: 00779 REV: A SHEET: 4 OF 2
---	---	--