

FEATURES

- Low-cost permanent attachment method for iButton
- Readily attaches iButton to any smooth flat surface
- Available in die-cut rolls of 500/roll with a core inner diameter of 76 mm (3 inch)
- Excellent U.V. resistance in outdoor weathering tests and weather-o-meter tests
- 24 months shelf life at 21°C and 50% relative humidity
- Ideal application temperature 21°C to 38°C; minimum application temperature 10°C; maximum long term temperature 71°C

ORDERING INFORMATION

DS9096P+ Roll of 500 Adhesive Pads
 +Denotes a lead(Pb)-free/RoHS-compliant product.

DESCRIPTION

The DS9096P is made of white, double-coated acrylic VHB™ foam tape (3M part number 4932) that is die-cut to match the diameter of iButton devices. The pads allow iButtons to be attached to virtually any smooth surface. The DS9096P offers an excellent long-term holding power for use in many interior and exterior industrial applications.

The DS9096P works best on low surface energy substrates, including most metal, sealed wood and glass, as well as many plastics, composites and painted surfaces. Porous (e.g., concrete) or fibrous materials (e.g., wood) will require sealing to provide a unified surface. Materials such as copper, brass, plasticized vinyl may require priming or coating to prevent interaction between adhesive and substrate. Bonding to glass, ceramic tile or other hydrophilic surfaces in a high humidity environment may require the use of a silane coupling-agent to help ensure a long-term bond. Rough surfaces created by light abrasion may actually be detrimental to bond strength.

Before applying the DS9096P, clean the surface of the objects thoroughly with a mixture of 50% isopropyl alcohol and 50% water and wipe it dry. Bond strength is dependent upon the amount of adhesive-to-surface contact developed. Firm application pressure develops better adhesion contact and thus improves bond strength. For good surface contact apply enough pressure to ensure that the tape experiences approximately 15 psi (100 kPa). Typically, uniform thumb pressure on the iButton will achieve the desired result. At room temperature approximately 50% of the ultimate bonding strength is achieved after 20 minutes, 90% after 24 hours and 100% after 72 hours.

For complete tape information see <http://www.3m.com/bonding/pdf/501622.pdf>

"VHB" is a trademark of 3M.

iButton is a trademark of Maxim Integrated Products, Inc.

DIMENSIONS

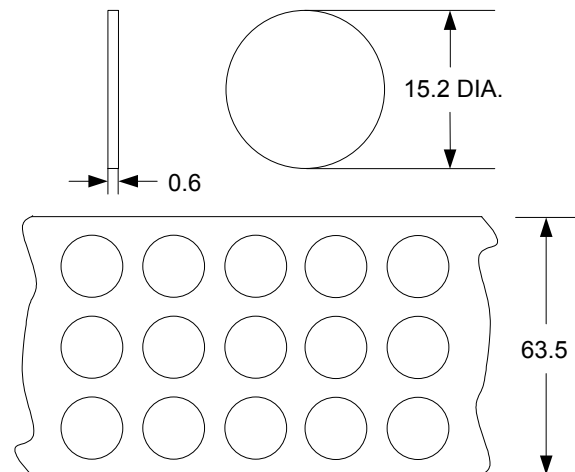

All dimensions are shown in millimeters.

REVISION HISTORY

REVISION DATE	DESCRIPTION	PAGES CHANGED
8/09	Added an <i>Ordering Information</i> table.	1