

DRAWING MADE IN AMERICAN PROJECTION

© COPYRIGHT 1973 BY AMP INCORPORATED, HARRISBURG, PA. ALL INTERNATIONAL RIGHTS RESERVED.

THIS PRODUCT DESIGNED AND BUILT BY AMP INCORPORATED. NO LICENSE TO USE THAT DESIGN IN MANUFACTURE, OR TO USE ANY ISSUED OR PENDING PATENTS WHICH ARE INVOLVED, IS IMPLIED.

Unpublished copy not to be reproduced or published without written permission of AMP Incorporated

REVISIONS				
ZONE	LTR	DESCRIPTION	DATE	APPROVED
	A	REV. & REDRAWN	6-4-73	Ken X
	B	OBSOLETE -2 ECN 53630	1-29-87	gth
	C	REV PER ECN 5-3960	4-12-87	RJ
	D	REACTIVATION -2 DF-7279	2-93	DE 9/11/93
	E	ECO-10-007742 PY	4-10	DE

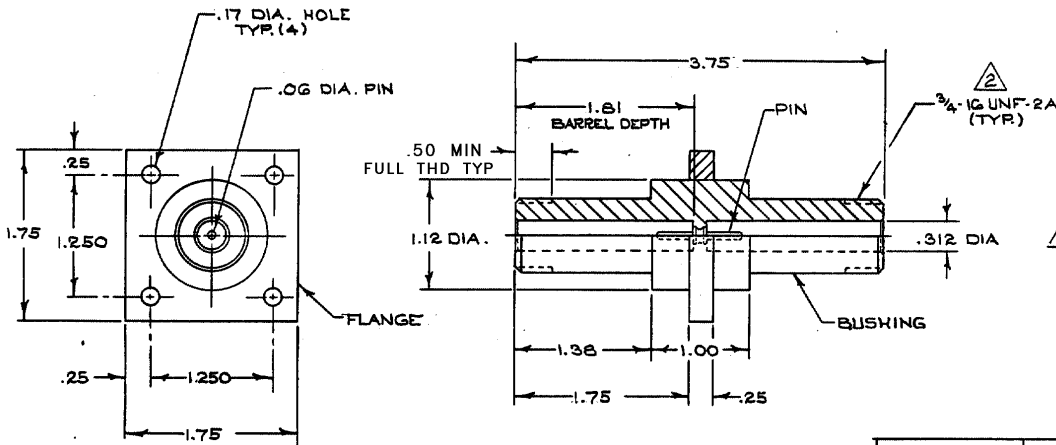

1 RECEPTACLE TO MATE WITH AMP LGH-3 LEAD ASSEMBLY, AVAILABLE SEPARATELY.
 2 PER FEDERAL STANDARD H-2B 3 WIRE METHOD. DIMENSION OVER WIRES TO BE: .7474-.7654.

850909-2	AS SHOWN WITH GOLD PLATED PIN
850909-1	AS SHOWN WITH TIN PLATED PIN

QTY REQD	QTY REQD	ITEM NO	DWG SIZE	PART OR IDENTIFYING NO	NOMENCLATURE OR DESCRIPTION	SYMBOL
-2	-1					

UNLESS OTHERWISE SPECIFIED: DECIMALS } .00 ± .02 .005 ± .005 ANGLES } ± HOLES } .251 TO .500 OVER .500 DIMENSIONS ARE IN INCHES				CONTRACT NO DR L. GEIB 6-10-69		 AMP INCORPORATED Elizabethtown, Pa.			
MATERIAL MOLDED GLASS EPOXY				NAME LGH-3 RECEPTACLE FEED THRU ASSY (FOR BULKHEAD APPLICATION)					
FINISH BLACK				DSGN APPD J. V. GAY 6-12-69		SIZE B	CODE IDENT NO 89110	NUMBER 850909	REV E
NEXT ASSY	FINAL ASSY	NEXT ASSY	USED ON	OTHER APPD		SCALE	WT	SHEET	OF

DO NOT SCALE PRINT

CUSTOMER DRAWING