

4

3

2

1

THIS DRAWING IS UNPUBLISHED. RELEASED FOR PUBLICATION. ALL RIGHTS RESERVED.

LOC	DIST	REVISIONS					
DF	SO	P	LTR	DESCRIPTION	DATE	BY	APPD
		H1		REVISED PER ECO-11-005030	11MAR11	RK	HMR

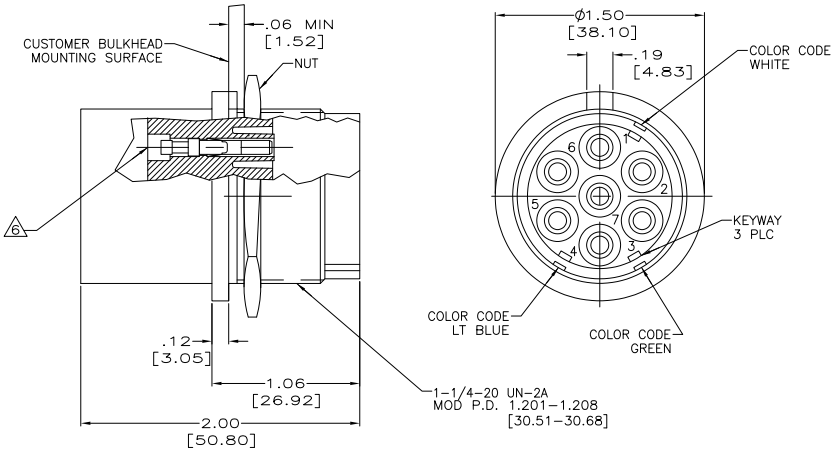

- SEVEN CONTACT CAVITIES ACCEPT TYPE II, SIZE 16 SOCKETS AND COAX CONTACTS AS SHOWN IN TABLE. EXTRACTION TOOL PART NUMBER IS 861751-1.
- TYPE II SOCKETS TO ACCEPT 22 AWG - 24 AWG STRANDED WIRE. SOCKETS GOLD PLATED PER MIL-G-45204 TYPE II .00050 MIN THK.
- RECEPTACLE WILL WITHSTAND WITHOUT BREAKDOWN, 27 KVDC PIN TO PIN & 27 KVDC PIN TO GRD WHEN MATED WITH 861648-1.
- TYPE II SOCKETS TO ACCEPT ONE 16 AWG OR ONE 18 AWG STRANDED WIRE.
- TYPE II SOCKETS TO ACCEPT 14 AWG STRANDED WIRE.
- CUSTOMER TO ATTACH LEADS & PROTECT AGAINST ARC OVER & BREAKDOWN BY POTTING. SOCKETS TO BE COATED WITH RTV108

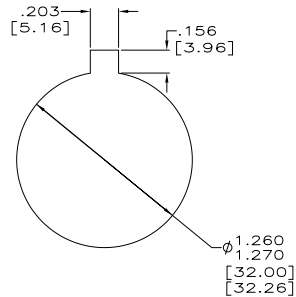

RECOMMENDED PANEL CUTOUT

6	NO	45098	14	861647-9
5	NO	45098	16,18	861647-8
2	NO	45099	20,22,24	861647-7
	YES	NO SOCKETS		861647-6
6	YES	45098	14	861647-5
	YES	5 COAX 69656	20-24 & COAX	861647-4
	YES	1 COAX 69656	20-24 & COAX	861647-3
5	YES	45098	16,18	861647-2
2	YES	45099	20,22,24	861647-1
RMKS	COLOR CODING	HAND TOOL	WIRE SIZE RANGE	PART NUMBER

THIS DRAWING IS A CONTROLLED DOCUMENT.		BY T. THOMPSON 03-22-95	TE Connectivity	
DIMENSIONS: INCHES [mm]		CHK D. EASY 04-19-95	RECEPTACLE, FLANGED H.V. 7 CONTACT, LGH	
MATERIAL MOLDED PLASTIC		FINISH BLACK	SIZE A2	CAGE CODE 00779
DRAWING NO. C-861647		SCALE 2:1	SHEET 1 of 1	REV H1