

DRAWING MADE IN AMERICAN PROJECTION

©1976 BY AMP INCORPORATED. ALL RIGHTS RESERVED. AMP PRODUCTS COVERED BY PATENTS AND/OR PATENTS PENDING.

THIS PRODUCT DESIGNED AND BUILT BY AMP INCORPORATED. NO LICENSE TO USE THAT DESIGN IN MANUFACTURE, OR TO USE ANY ISSUED OR PENDING PATENTS UNLESS AS INVOLVED, IS GRANTED.

REVISIONS				
ZONE	LTR	DESCRIPTION	DATE	APPROVED
A		REV PER 01414-0120-84	CT	10-04 CT

Unpublished copy not to be reproduced or published without written permission of AMP INCORPORATED

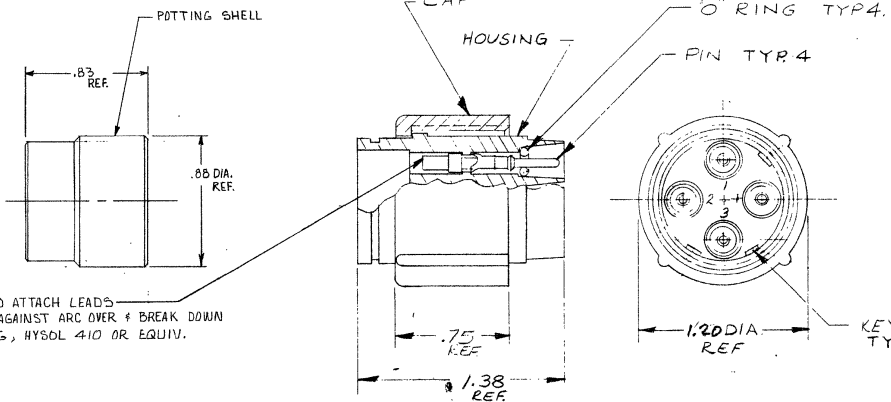

CUSTOMER TO ATTACH LEADS & PROTECT AGAINST ARC OVER & BREAK DOWN BY POTTING, HYSOL 410 OR EQUIV.

- NOTE:
1. MARKING, WHITE.
 2. #16 GA. PINS, GOLD PLATED PER MIL-G-45204, TYPE II, .0005 THK. FIN.
 3. PLUG & PINS SHIPPED SEPARATELY.
 4. TYPE II PINS TO ACCEPT (1) 22 AWG (1) 20 AWG OR (1) 24 AWG STRANDED WIRE.
 5. TYPE II PINS TO ACCEPT (1) 18 AWG OR 18 AWG STRANDED WIRE.
 6. TO REMOVE PINS USE EXTRACTION TOOL NO. 860751-1
 7. TYPE II PINS TO ACCEPT ONE (1) 14 AWG STRANDED WIRE.

AMP P/N	WIRE SIZE RANGE	HAND TOOL
863022-1	20, 22, 24	45093
863022-2	16, 18	45098
863022-3	14	45098

QTY. REQD	QTY. RECD	ITEM NO.	DWG. SIZE	PART OR IDENTIFYING NO.	NOMENCLATURE OR DESCRIPTION	SYMBOL
-2	-1				PARTS LIST	
CONTRACT NO.					AMP INCORPORATED CAPITRON DIVISION ELIZABETHTOWN, PENNSYLVANIA	
DR DICK STONE 3-4-76					NAME PLUG ASS'Y. 4 PIN.	
CHK					LGH	
APPD <i>M. Gordon 3/3/76</i>					SIZE CODE IDENT NO. NUMBER	
DSGN APPD					C	00779 863022
OTHER APPD					SCALE NONE	WT
					SHEET 10/11	

UNLESS OTHERWISE SPECIFIED: DIMENSIONS ARE IN INCHES TOLERANCES
.00 ±
.000 ±
ANGLES
MATERIAL: MOLDED PLASTIC
FINISH: BLACK
NEXT ASSY
FINAL ASSY
NEXT ASSY
USED ON
APPLICATION