

THIS DRAWING IS UNPUBLISHED. RELEASED FOR PUBLICATION
 © COPYRIGHT 19 BY AMP INCORPORATED. ALL INTERNATIONAL RIGHTS RESERVED.

PROJ	LOC	DIST	P	F	ZONE	LTR	REVISIONS	DATE	APPD	
4085	DF	50				M	REV PER 0600-5644-96	MEP	1-97	SG

PART NO.	DIM A	DIM B	DIM C	TERMINAL PLATING	SIZE
849587-1	1.125 [28.6]	1.250 [31.7]	.468 [11.9]	1	LGH-2
849587-2	1.125 [28.6]	1.250 [31.7]	.468 [11.9]	2	LGH-2
849587-3	1.000 [25.4]	1.125 [28.6]	.468 [11.9]	1	LGH-2
849587-4	1.000 [25.4]	1.125 [28.6]	.468 [11.9]	2	LGH-2
849587-5	.875 [22.2]	1.000 [25.4]	.468 [11.9]	1	LGH-2
849587-6	.875 [22.2]	1.000 [25.4]	.468 [11.9]	2	LGH-2
849587-7	.750 [19.0]	.875 [22.2]	.468 [11.9]	1	LGH-2
849587-8	.750 [19.0]	.875 [22.2]	.468 [11.9]	2	LGH-2
849587-9	1.812 [46.0]	1.937 [49.2]	.312 [7.9]	1	LGH-3
1-849587-0	1.812 [46.0]	1.937 [49.2]	.312 [7.9]	2	LGH-3
1-849587-1	1.437 [36.5]	1.562 [39.7]	.468 [11.9]	1	LGH-2
1-849587-2	1.437 [36.5]	1.562 [39.7]	.468 [11.9]	2	LGH-2
1-849587-3	.750 [19.0]	.875 [22.2]	.312 [7.9]	1	LGH-3
1-849587-4	.750 [19.0]	.875 [22.2]	.312 [7.9]	2	LGH-3
1-849587-5	.875 [22.2]	1.000 [25.4]	.312 [7.9]	1	LGH-3
1-849587-6	.875 [22.2]	1.000 [25.4]	.312 [7.9]	2	LGH-3
1-849587-7	1.000 [25.4]	1.125 [28.6]	.312 [7.9]	1	LGH-3
1-849587-8	1.000 [25.4]	1.125 [28.6]	.312 [7.9]	2	LGH-3
1-849587-9	1.125 [28.6]	1.250 [31.7]	.312 [7.9]	1	LGH-3
2-849587-0	1.125 [28.6]	1.250 [31.7]	.312 [7.9]	2	LGH-3
6-849587-0	1.812 [46.0]	1.937 [49.2]	.312 [7.9]	1	LGH-3
6-849587-1	1.437 [36.5]	1.562 [39.7]	.468 [11.9]	1	LGH-2

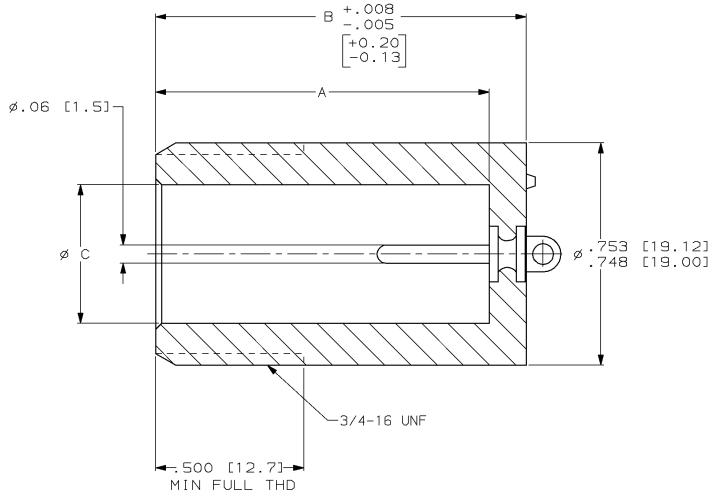

- 1 TIN PLATED .0001 [0.0025] MIN THK PER MIL-T-10727, TYPE I OR II.
- 2 GOLD PLATED .000030 [0.00076] MIN THK PER MIL-G-45204, TYPE II.
- 3 GOLD PLATED .000050 [0.00127] MIN THK PER MIL-G-45204, TYPE II.
- 4. LGH-2 RECEPTACLE TO MATE WITH AMP LGH-2 LEAD ASSEMBLY.
- 5. LGH-3 RECEPTACLE TO MATE WITH AMP LGH-3 LEAD ASSEMBLY.

DO NOT SCALE PRINT. UNLESS SPECIFIED DIMENSIONS IN INCHES [mm] TOLERANCES ON: 2 PLC DEC ±.04 [1.0] 3 PLC DEC ±.015 [0.38] ANGLES ± -	DR 7-19-93 C.C.THOMAS CHK 7-21-93 D.EABY APPD 7-21-93 D.EABY	AMP Incorporated Harrisburg, PA 17105-3608	
MATERIAL -	NAME	MOLDED RCPT, LGH-2 & 3	
FINISH -	APPLICATION SPEC	SIZE C	CAGE CODE 00779
		DRAWING NO	C=849587
	WEIGHT -	SCALE 4:1	SHEET 1 OF 1

THIS DRAWING IS A CONTROLLED DOCUMENT FOR AMP INCORPORATED. IT IS SUBJECT TO CHANGE AND THE CONTROLLING ENGINEERING ORGANIZATION SHOULD BE CONTACTED FOR THE LATEST REVISION.