

DRAWING MADE IN THIRD ANGLE PROJECTION

THIS DRAWING IS UNPUBLISHED.		RELEASED FOR PUBLICATION	
© COPYRIGHT 19		BY AMP INCORPORATED. ALL INTERNATIONAL RIGHTS RESERVED.	
PART NO.	WIRE SIZE		
861076-1	.107/.113	[2.72/2.87]	O.D. TEFLON WIRE
861076-2	.081/.087	[2.06/2.21]	O.D. TEFLON WIRE

PROD CODE	LOC	DIST	P	F	ZONE	LTR	DESCRIPTION	DATE	APPD
4092	DF	50							
						E	REV 0600-0678-93 TT	09-93	SG
						F	REV PER 0600-4150-95 CT	8-95	DE
						G	REV PER 0600-6380-97 TT	09-97	SG

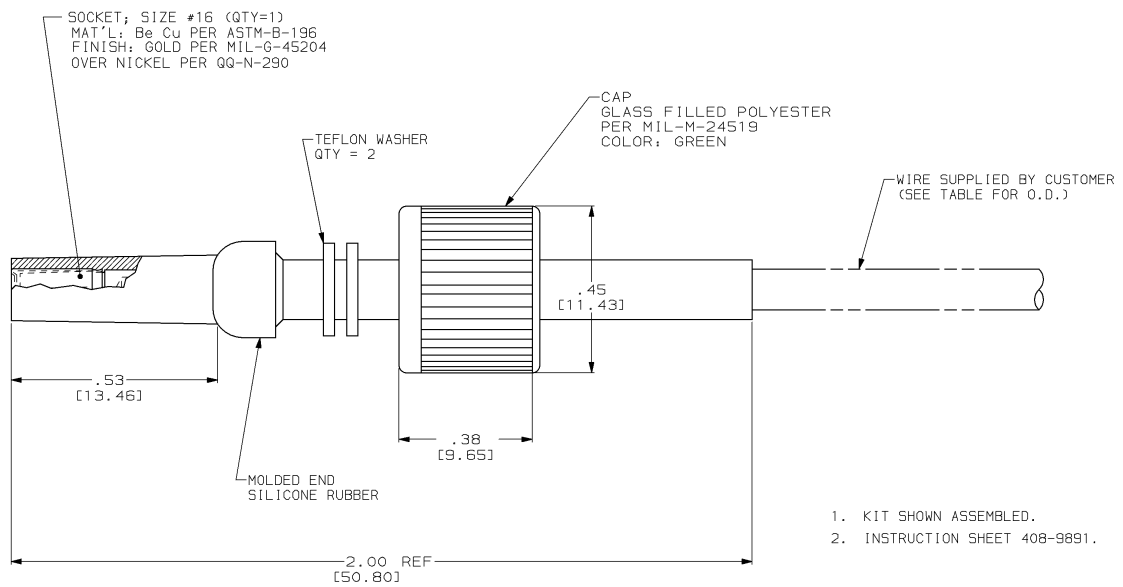

1. KIT SHOWN ASSEMBLED.
2. INSTRUCTION SHEET 408-9891.

DO NOT SCALE PRINT. UNLESS SPECIFIED DIMENSIONS IN INCHES [mm] TOLERANCES ON: 2 PLC DEC ± .02 [0.5] 3 PLC DEC ± .005 [0.127] ANGLES ± -		DR 09-02-93 THOMPSON		AMP INCORPORATED Harrisburg, Pa. 17105	
MATERIAL -		CHK 10-20-93 S. GLATFELTER			
FINISH -		APPD 10-20-93 S. GLATFELTER		NAME LGH 1/2 REPAIR KIT	
WEIGHT -		APPLICATION SPEC -		SIZE C	CAGE CODE 00779
				DRAWING NO. 861076	SHEET 1 OF 1

CUSTOMER DRAWING

861076

A