

4

3

2

1

THIS DRAWING IS UNPUBLISHED. RELEASED FOR PUBLICATION - N/A.
 © COPYRIGHT N/A BY TYCO ELECTRONICS CORPORATION. ALL RIGHTS RESERVED.

LOC	DIST	REVISIONS					
DF	SO	P	LTR	DESCRIPTION	DATE	MIN	APD
		M		REV PER ECO-06-025223	31OCT06	PY	DE

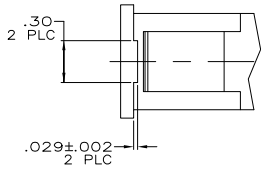

DETAIL I

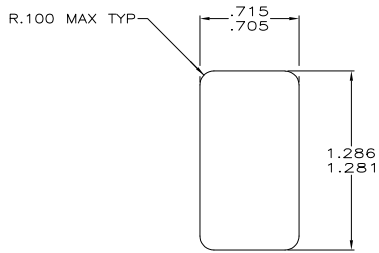
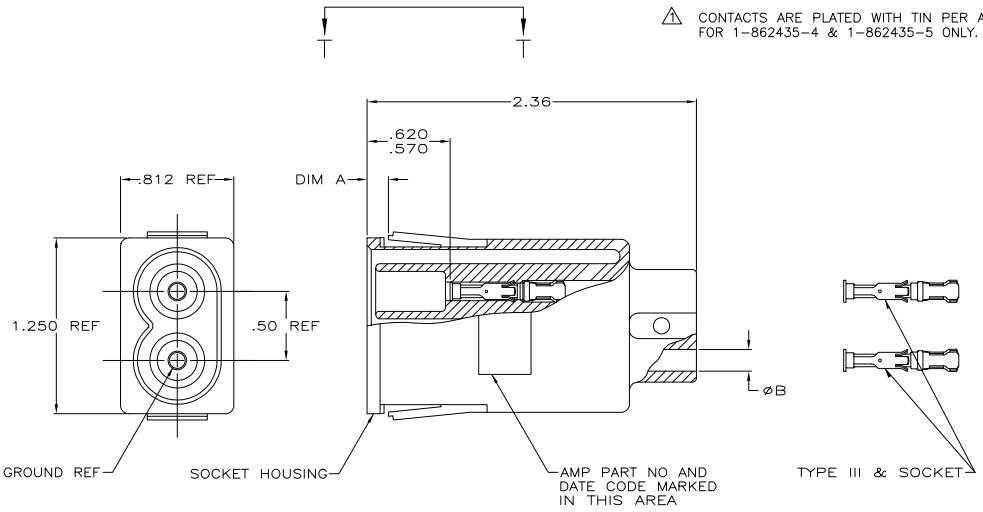

RECOMMENDED PANEL CUTOUT

90067-2	18-16	.200	.062	1-66101-9	1-862435-5
90067-2	18-16	.125	.062	1-66101-9	1-862435-4
90067-2	22-20	.125	.030	66399-1	1-862435-3
90067-2	18-16	.125	.030	66101-2	1-862435-2
90067-2	22-20	.200	.030	66399-1	1-862435-1
90067-2	18-16	.200	.030	66101-2	1-862435-0
90067-2	22-20	.125	.090	66399-1	862435-9
90067-2	18-16	.125	.090	66101-2	862435-8
90067-2	22-20	.200	.090	66399-1	862435-7
90067-2	18-16	.200	.090	66101-2	862435-6
90067-2	18-16	.200	.062	66101-1	862435-5
90067-2	22-20	.200	.062	66399-1	862435-4
90067-2	18-16	.200	.062	66101-2	862435-3
90067-2	22-20	.125	.062	66399-1	862435-2
90067-2	18-16	.125	.062	66101-2	862435-1

OBSELETE
 OBSELETE
 OBSELETE
 OBSELETE

HAND TOOL	WIRE SIZE RANGE (AWG)	INSUL DIA	DIM A	SOCKET NO.	PART NUMBER
-----------	-----------------------	-----------	-------	------------	-------------

THIS DRAWING IS A CONTROLLED DOCUMENT. DR: C.C. THOMAS 15-MAY-03
 OK: J. EASY 15-MAY-03
 APP: J. EASY 15-MAY-03

TYCO Electronics Tyco Electronics Corporation
 Harrisburg, Pa 17105-3608

2 CAVITY RECEPTACLE KIT LGH

APPLICATION SPEC: PRODUCT SPEC: SIZE: CHG CODE: DRAWING NO: A2 00779 C-862435
 WEIGHT: RESTRICTED TO: CUSTOMER DRAWING SCALE: 2:1 SHEET 1 OF 1 REV M