

HC-KA 24-BU/PER

Order No.: 1772955

The illustration shows version HC-KA-B 16-BU/PER

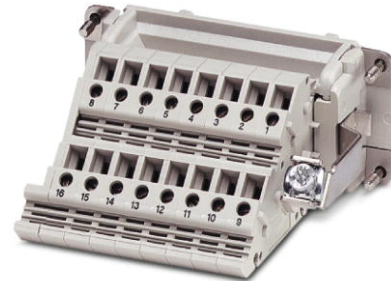

<http://eshop.phoenixcontact.de/phoenix/treeViewClick.do?UID=1772955>

HEAVYCON terminal adapter female insert, B24 series, 24. pos., protective conductor connection on the right for the left side of the control cabinet, screw connection; contact inserts with screw, crimp, and QUICKON connections usable as mating connectors.

Commercial data	
EAN	4017918037567
Pack	5 pcs.
Customs tariff	85369010
Weight/Piece	0.1997 KG
Catalog page information	Page 382 (PC-2007)

Product notes

WEEE/RoHS-compliant since:
12/01/2005



<http://www.download.phoenixcontact.com>
Please note that the data given here has been taken from the online catalog. For comprehensive information and data, please refer to the user documentation. The General Terms and Conditions of Use apply to Internet downloads.

Technical data

Electrical characteristics

Note	For HEAVYCON ADVANCE panel mounting flange and HEAVYCON panel mounting base of type B24. Contact inserts with screw, crimp, and QUICKON connections can be used as mating connectors.
------	---

Number of positions	24
Connection in acc. with standard	IEC / EN
Rated voltage (III/3)	400 V
Rated surge voltage	6 kV
Rated current	16 A

Mechanical characteristics

Design	B24
Connection method	Screw connection
Tightening torque	0.5 Nm ... 0.8 Nm
Stripping length of the individual wire	14 mm
Conductor cross section	0.2 mm ² ... 2.5 mm ²
Connection cross section AWG	22 ... 12

General characteristics

Contact material	Copper alloy
Contact surface material	Ag
Contact carrier material	PA / PC
Terminal adapter width	85.7 mm
Pollution degree	3
Surge voltage category	III
Inflammability class acc. to UL 94	V0
Connection in acc. with standard	IEC / EN
Ambient temperature (operation)	-40 °C ... 125 °C
Assembly instructions	Connectors may be operated only when there is no load/voltage.

Certificates / Approvals



Certification CSA, GOST, UL

CSA

Nominal voltage U _N	300 V
Nominal current I _N	9 A
AWG/kcmil	22-12

UL

Nominal voltage U_N	600 V
Nominal current I_N	10 A
AWG/kcmil	22-12

Accessories

Item	Designation	Description
Assembly		
1775240	HC-KA-FE	Foot element, for mounting on DIN rail NS 32, DIN rail NS 35/7.5 or DIN rail NS 35/15, can be inserted between basic and side element
1660083	HC-VSH	Locking screw barrel, for a firm connection of contact inserts and DIN-rail mountable terminal adapters

Diagrams/Drawings

Diagram

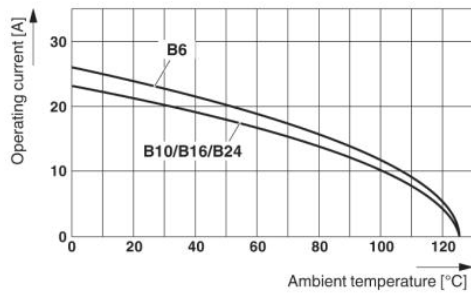

Dimensioned drawing

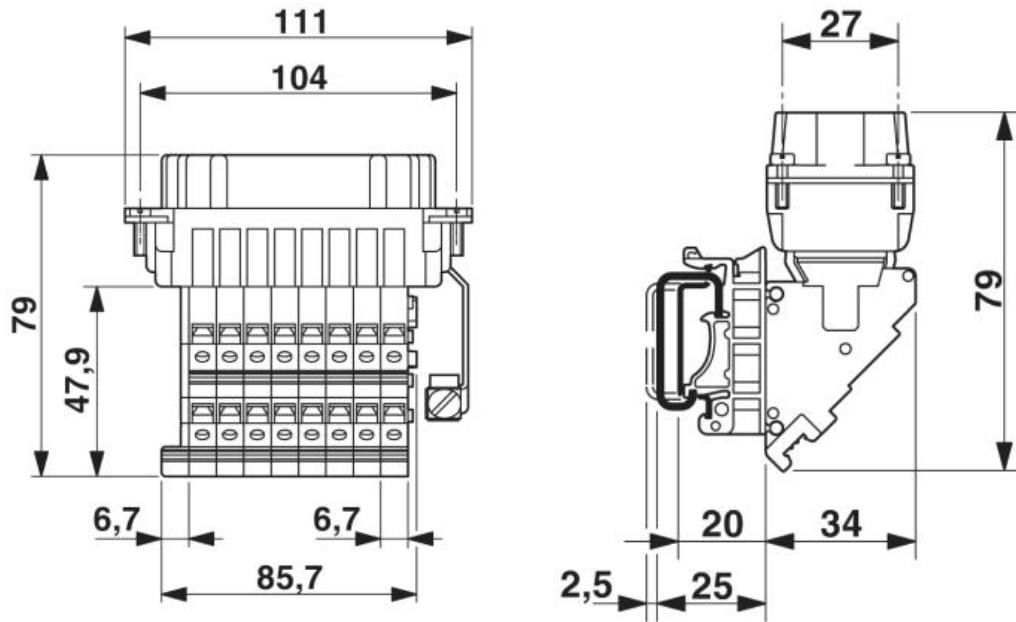

Schematic diagram

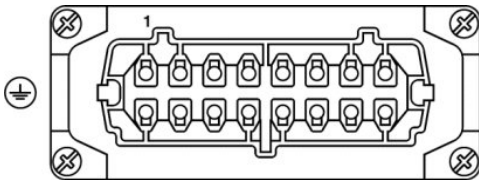

Address

PHOENIX CONTACT Deutschland GmbH
Flachsmarktstr. 8
32825 Blomberg, Germany
Phone +49 5235 3 12000
Fax +49 5235 3 41200
<http://www.phoenixcontact.de>



© 2010 Phoenix Contact
Technical modifications reserved;