

REVISIONS				
P	LYR	DESCRIPTION	DATE	BY
R		REVISE PER 0A00-0544-04	25OCT2004	BB SM
S		REVISE PER ECR-05-007414	25JUL2005	BB SB
T		REVISE PER ECR-08-000844	23JAN2008	BB SM

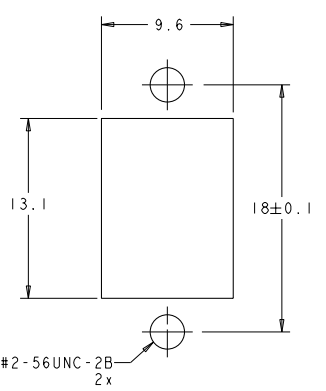

△ MATERIAL:
 HOUSING: PBT-GF30, SEE DASH NUMBERS FOR COLOR.*
 RETAINER: PEI-GF30, COLOR: BLACK.*
 RETENTION CLIP: STAINLESS STEEL.
 ALIGNMENT SLEEVE: SEE DASH NUMBERS.
 PROTECTIVE COVER: TPE, COLOR: BLACK.*
 *UL94 V-0 RATED AT QUALIFYING THICKNESS.

SUGGESTED PANEL CUTOUT
 MAX. PANEL THICKNESS 1.7

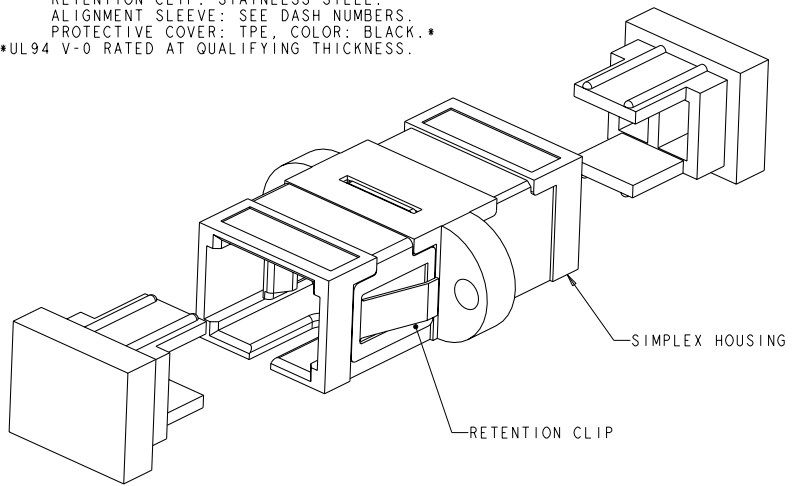

RETENTION CLIP	METAL	GREEN	2-502632-1
RETENTION CLIP	CERAMIC	BEIGE	1-502632-2
RETENTION CLIP	CERAMIC	BLUE	1-502632-1
RETENTION CLIP	CERAMIC	BLACK	1-502632-0
RETENTION CLIP	METAL	BEIGE	502632-9
RETENTION CLIP	METAL	BLUE	502632-8
RETENTION CLIP	METAL	BLACK	502632-7
INCLUDED HARDWARE	ALIGNMENT SLEEVE	COLOR	PART NUMBER

DIMENSIONS: mm 0 PLC ±0.1 1 PLC ±0.1 2 PLC ±0.05 3 PLC ±0.1 4 PLC ±0.1 ANGLES ±0.1 FINISH		OWN: B. BRIGGS 25OCT2004 CEC: S. MILLER 25OCT2004 APPD: S. BUCHTER 25OCT2004 PRODUCT SPEC: APPLICATION SPEC: WEIGHT: CUSTOMER DRAWING	Tyco Electronics Harrisburg, PA 17105-3608 RECEPTACLE ASSEMBLY, AMP SC TO SC SHEET: A200779 CASE CODE: C-502632 DRAWING NO: RESTRICTED TO:
---	--	---	---