

4

3

2

1

THIS DRAWING IS UNPUBLISHED. RELEASED FOR PUBLICATION. BY TYCO ELECTRONICS CORPORATION. ALL RIGHTS RESERVED. COPYRIGHT 19

MATERIAL: HOUSING: DIECAST ZINC, NICKEL PLATED. SLEEVE: SEE DASH NO'S. RETAINER: PEI GF30, COLOR: BLACK, UL94 V-0 RATED AT QUALIFYING THICKNESS. PROTECTIVE COVER: TPE, COLOR: BLACK, UL94 V-0 RATED AT QUALIFYING THICKNESS. RETENTION CLIP: STAINLESS STEEL.

BULK PACKAGE.

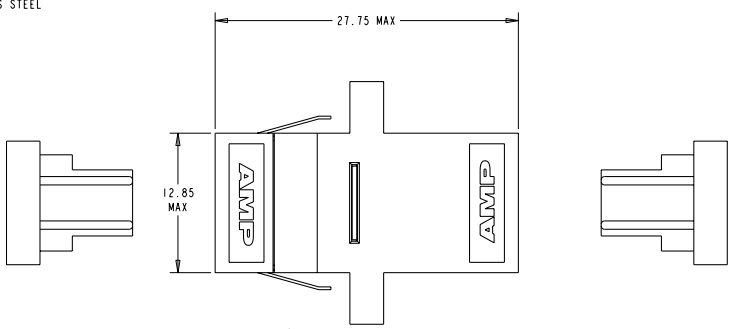

REV	DATE	BY	APP'D
A	07JUN2006	BB	SM

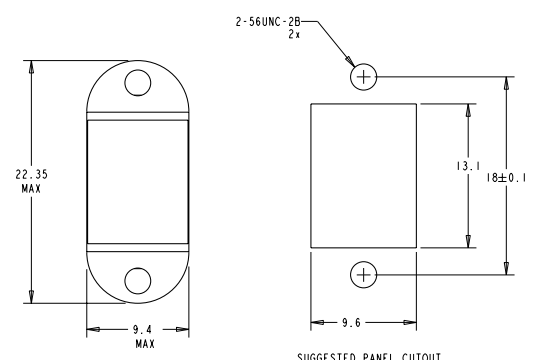

SUGGESTED PANEL CUTOUT MAX PANEL THICKNESS 1.7

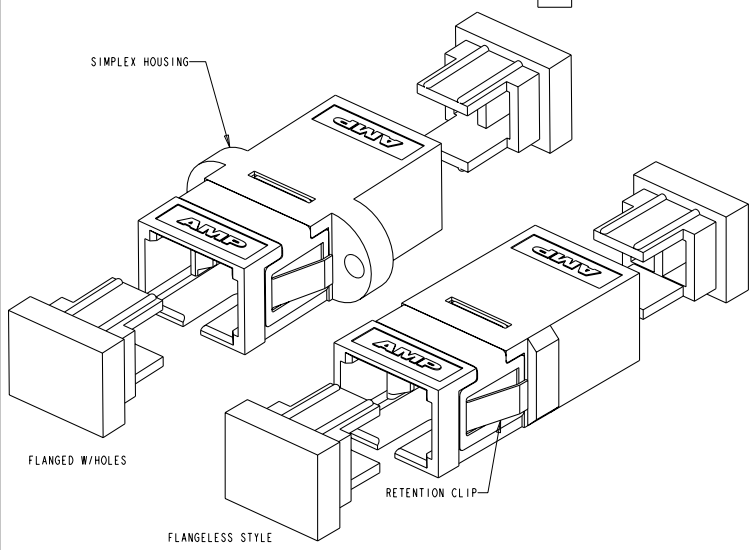

REV	DESCRIPTION	PART NO
1	CERAMIC FLANGED W/HOLES, NO CLIP	1-6278348-2
2	CERAMIC FLANGELESS, NO CLIP	1-6278348-0
3	METAL FLANGED W/HOLES, NO CLIP	6278348-9
4	CERAMIC FLANGELESS	6278348-8
5	CERAMIC FLANGELESS	6278348-7
6	METAL FLANGELESS	6278348-6
7	METAL FLANGELESS	6278348-5
8	CERAMIC FLANGED W/HOLES	6278348-4
9	CERAMIC FLANGED W/HOLES	6278348-3
10	METAL FLANGED W/HOLES	6278348-2
11	METAL FLANGED W/HOLES	6278348-1

AMP INCORPORATED
HARRISBURG, PA 17105-3608

OWN: B. BRIGGS 12MAY2005
CHK: S. MILLER 12MAY2005
APP'D: S. BLUCHTER 12MAY2005

NAME: RECEPTACLE ASSEMBLY, AMP SC TO SC

PRODUCT SPEC: -
APPLICATION SPEC: -
WEIGHT: -
MATERIAL: -

SCALE: 4:1 SHEET 1 OF 1 REV A