

ACTIVE DEVICE MOUNT BODY

PART NAME	DIM AA	DIM BB
ADM BODY	5.97 MAX	20.1 REF
ADM BODY, LOW PROFILE	4.70 MAX	18.8 REF

1. ACCEPTS ACTIVE DEVICES, TO-52, TO-18, TO-46, OR LOW COST HONEYWELL SWEETSPOT.

△ BULK PACKAGED.

△ MATERIAL:
 ADM BODY: NICKEL PLATED ZINC
 PROTECTIVE CAP: PVC, COLOR: RED, NON-FR.
 ALIGNMENT SLEEVE: PBT, COLOR: BLACK, UL94 V-0 RATED QUALIFYING THICKNESS.
 LOCKWASHER: STAINLESS STEEL
 HEX NUT: NICKEL PLATED BRASS

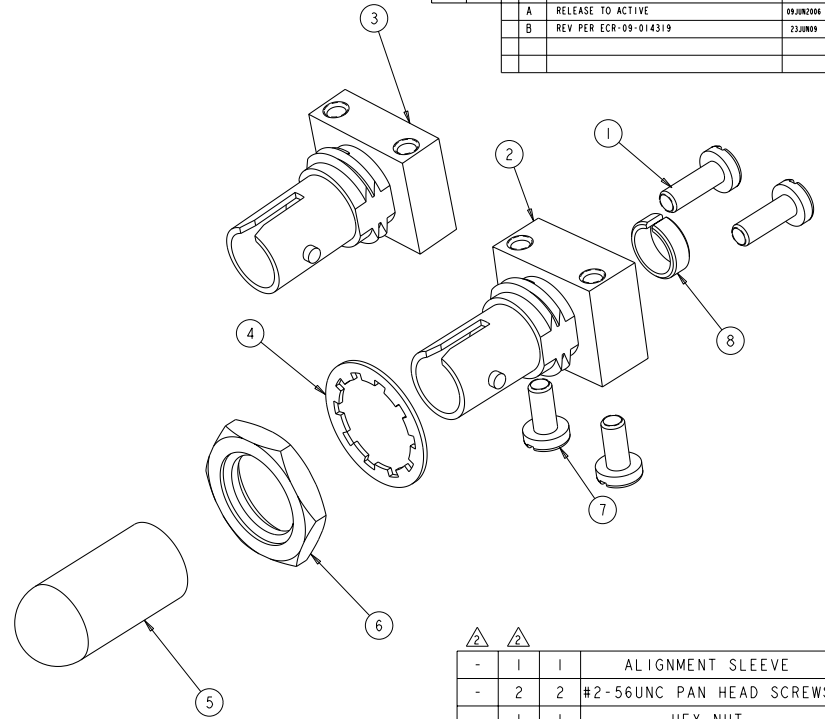

REV	DATE	BY	CHKD	APPROV
A	09JUN2006	BB	SB	
B	23JUN09	JZ	SM	

QTY	REV	DESCRIPTION	ITEM NO.	
-	1	1	ALIGNMENT SLEEVE	8
-	2	2	#2-56UNC PAN HEAD SCREWS	7
-	1	1	HEX NUT	6
1	1	1	PROTECTIVE CAP	5
-	1	1	LOCKWASHER	4
1	-	-	ADM BODY, LOW PROFILE	3
-	1	1	ADM BODY	2
-	2	2	#2-56UNC PAN HEAD SCREWS	1
-3	-2	-1	PART NUMBER	ITEM NO.

DIMENSIONS: mm 0 PLC ± 1 PLC ± 2 PLC ± 3 PLC ± 4 PLC ± ANGLES ± MATERIAL FINISH	TOLERANCES UNLESS OTHERWISE SPECIFIED: FRACTIONS DECIMALS 3/16 0.1875 1/8 0.125 3/32 0.09375 1/4 0.25 5/16 0.3125 3/8 0.375 1/2 0.5 5/8 0.625 3/4 0.75 7/8 0.875 1 1.0 1 1/8 1.125 1 1/4 1.25 1 3/8 1.375 1 1/2 1.5 1 5/8 1.625 1 3/4 1.75 1 7/8 1.875 2 2.0	DWG NO. 240CT2005 DESIGNED BY B. BRIGGS DATE 24OCT2005 CHECKED BY S. BUCHTER DATE 24OCT2005 APPROVED BY S. BUCHTER DATE 24OCT2005 APPLICATION SPEC WEIGHT CUSTOMER DRAWING	Tyco Electronics Corporation Shanghai, China NAME: ACTIVE DEVICE MOUNT KIT, 2.5mm BAYONET, OPTIMATE SIZE: A2 CASE CODE: 00779 DRAWING NO.: 5501474 SCALE: 5:1 SHEET: 1 OF 1 REV: B
--	--	---	--