

DRAWING MADE IN THIRD ANGLE PROJECTION
 THIS DRAWING IS UNPUBLISHED. RELEASED FOR PUBLICATION 19
 © COPYRIGHT 19 BY AMP INCORPORATED. ALL INTERNATIONAL RIGHTS RESERVED.

LOC		DIST		ZONE		LTR		REVISIONS		DATE	APPD
CE	16	P	F					C	REV PER 0A00-0319-96	7-8-96	DDE

- 1 CONNECTOR ASSY: AL, SST
 BOOT: THERMOPLASTIC ELASTOMER
 STEPPED SLEEVE: BRASS/COPPER
 PLUNGER: AL
- 2 STEPPED SLEEVE: Ni
- 3. ALL PART NO'S ARE BULK PACKAGED
 100 PCS/BAG

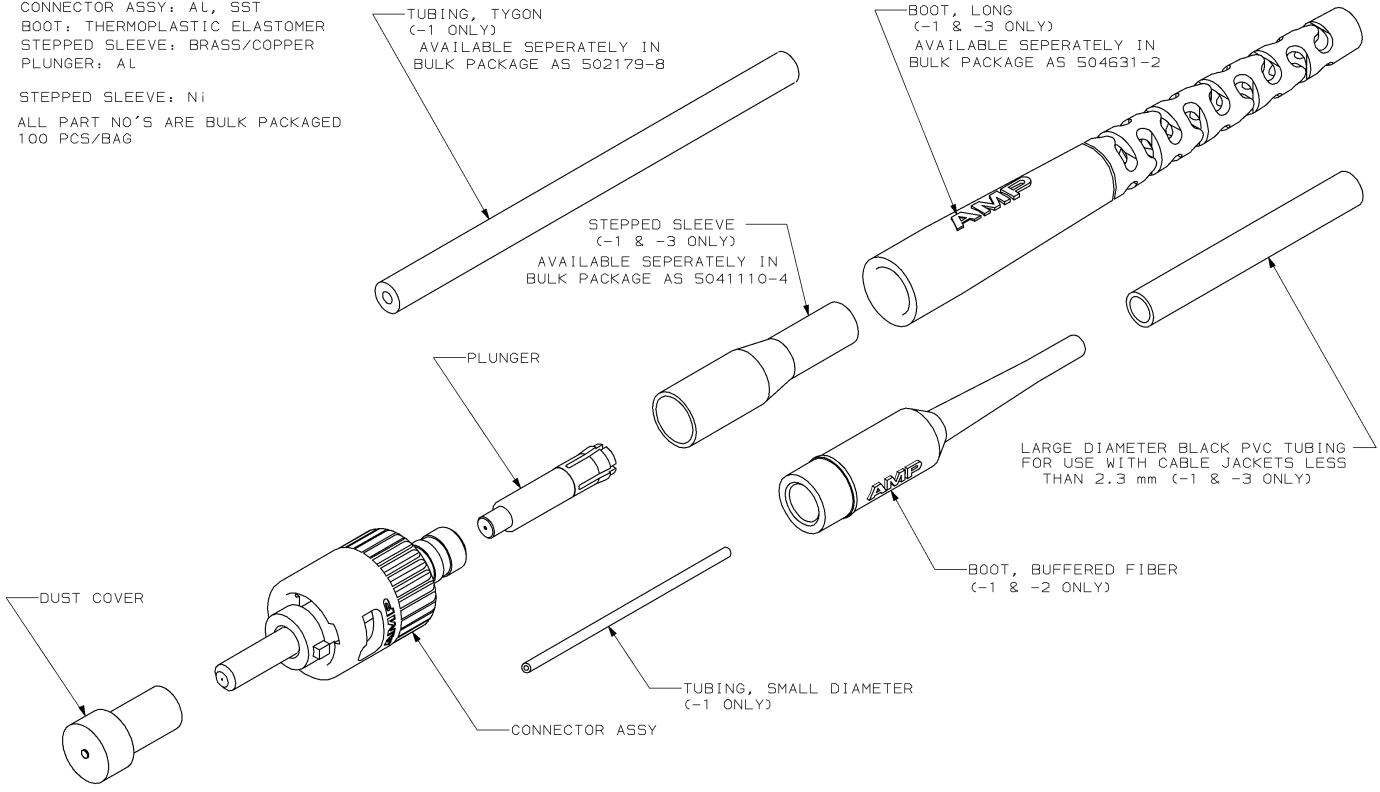

STEPPED SLEEVE	BOOT, LONG, BLK	3.0mm JACKETED CABLE	503904-3
-	BOOT, BUFF FIBER, BLK	900µm BUFFERED	503904-2
STEPPED SLEEVE	BOOT, LONG, BLK	3.0mm/900µm/250µm	503904-1
CRIMP SLEEVE	BOOT TYPE	DESCRIPTION	PART NO
DO NOT SCALE PRINT. UNLESS SPECIFIED DIMENSIONS IN mm [INCHES] TOLERANCES ON: 2 PLC DEC # - 3 PLC DEC # - ANGLES ± -	DR 2-8-95 D EROMAN	AMP Incorporated Harrisburg, PA 17105-3608 KIT, CONNECTOR, 125µm LightCrimp XTC SST, BULK PACKAGED	
MATERIAL	CHK 2-8-95 J MCKEE		
	APPD 2-8-95 B EDWARDS		
	PRODUCT SPEC		
FINISH	APPLICATION SPEC	SIZE	CAGE CODE
		©	00779
		DRAWING NO	©=503904
	WEIGHT	SCALE	SHEET
			1 OF 1

THIS DRAWING IS A CONTROLLED DOCUMENT FOR AMP INCORPORATED. IT IS SUBJECT TO CHANGE AND THE CONTROLLING ENGINEERING ORGANIZATION SHOULD BE CONTACTED FOR THE LATEST REVISION.