

4

3

2

1

THIS DRAWING IS UNPUBLISHED. RELEASED FOR PUBLICATION .19 .
 © COPYRIGHT 19 BY AMP INCORPORATED. ALL RIGHTS RESERVED.

LOC	QTY	REVISIONS			
P	LTR	DESCRIPTION	DATE	DWN	APVD
CE	16	D	REV PER 0A00-0503-95	12-4-95	DDE SB

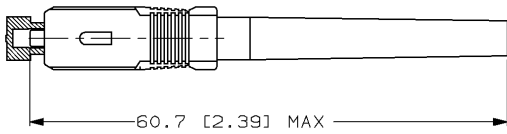

BLACK PVC TUBING
 USED WITH CABLES LESS
 THAN 3.0mm [.12]

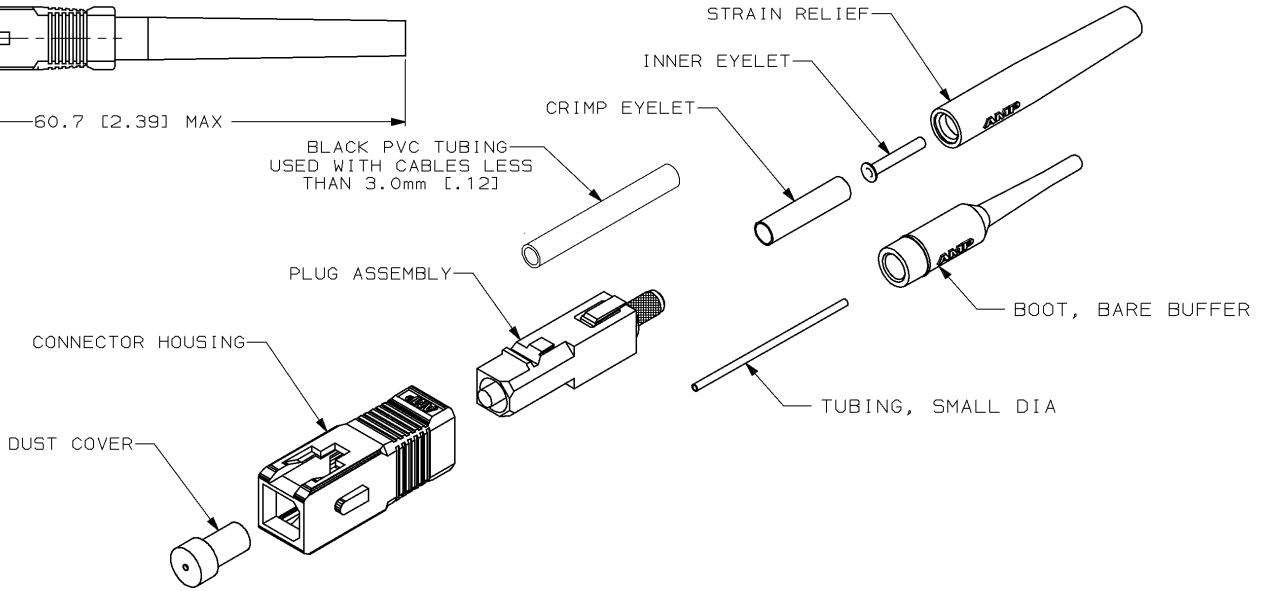

- 1 MATERIAL:
 PLUG BODY: THERMOPLASTIC, BEIGE
 CONNECTOR HOUSING: THERMOPLASTIC, BEIGE
 INTERNAL BODY: ZINC
 CRIMP EYELET: COPPER
 INNER EYELET: BRASS
 STRAIN RELIEF/BOOT: THERMOPLASTIC
 ELASTOMER, BEIGE
 CAPILLARY: ZrO₂

4. INSTRUCTION SHEET #408-4066

- 2 FINISH:
 INTERNAL BODY: ELECTROLESS NICKEL
 CRIMP EYELET: TIN

3. DIMENSIONS IN [] ARE IN INCHES.

DIMENSIONS:		TOLERANCES UNLESS OTHERWISE SPECIFIED:	
mm		0 PLC	±-
		1 PLC	±-
		2 PLC	±0.13(.005)
		3 PLC	±-
		4 PLC	±-
		ANGLES	±1°
MATERIAL	-	FINISH	-

125±2µm		503692-1	
FIBER SIZE		PART NO	
AMP AMP Incorporated Harrisburg, PA 17105-3608			
KIT, CONNECTOR, AMP LightCrimp SC SIMPLEX, MULTIMODE			
SIZE	CAGE CODE	DRAWINGS NO	
A3	00779	©-503692	
CUSTOMER DRAWING		SCALE	SHEET 1 OF 1 REV D
		2:1	