

DRAWING MADE IN THIRD ANGLE PROJECTION
 THIS DRAWING IS UNPUBLISHED. RELEASED FOR PUBLICATION 19
 © COPYRIGHT 19 BY AMP INCORPORATED. ALL INTERNATIONAL RIGHTS RESERVED.

LOC		DIST		ZONE		LTR		REV PER		REVISIONS		DATE	APPD
CE	16	P	F					H	REV PER 0A00-0296-97			6-23-97	DDE

- △ CONNECTOR ASSY: AL, CERAMIC
 BOOT; THERMOPLASTIC ELASTOMER, COLOR: YELLOW
 STEPPED SLEEVE: BRASS/COPPER
 PLUNGER: AL
- △ STEPPED SLEEVE: NI

LARGE Ø BLACK PVC TUBING
 FOR USE WITH CABLE
 JACKETS LESS THAN 2.3mm

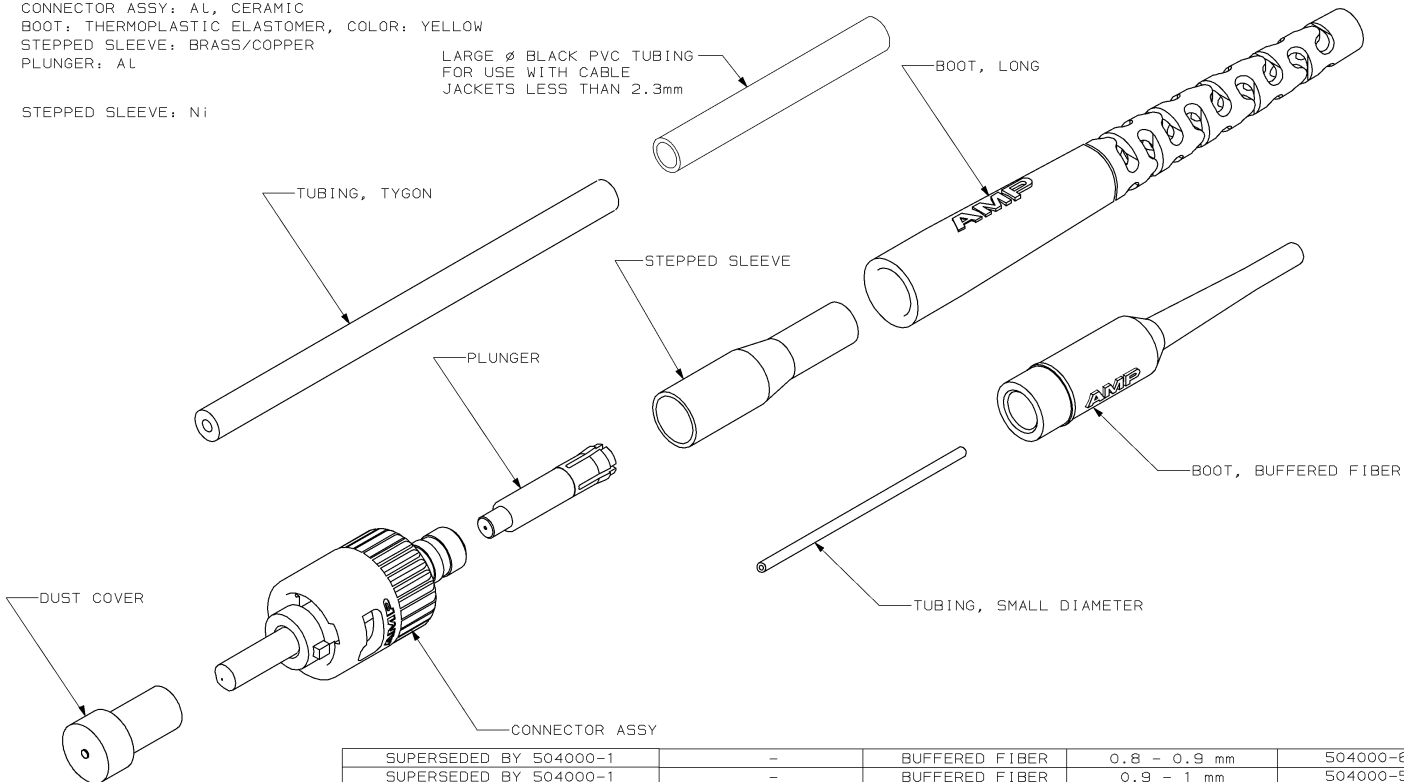

SUPERSEDED BY 504000-1	-	BUFFERED FIBER	0.8 - 0.9 mm	504000-6
SUPERSEDED BY 504000-1	-	BUFFERED FIBER	0.9 - 1 mm	504000-5
OBSOLETE	STEPPED SLEEVE	LONG	500µm	504000-4
SUPERSEDED BY 504000-1	-	BUFFERED FIBER	250µm	504000-3
SUPERSEDED BY 504000-1	STEPPED SLEEVE	LONG	0.8 - 0.9 mm	504000-2
	STEPPED SLEEVE	BUFFERED/LONG	250µm/ 0.8 - 1.0 mm	504000-1
	CRIMP SLEEVE	BOOT TYPE	BUFFER SIZE	PART NO

DO NOT SCALE PRINT. UNLESS SPECIFIED DIMENSIONS IN mm [INCHES] TOLERANCES ON + 2 PLC DEC # - 3 PLC DEC # - ANGLES ± -	DR 8-29-92 D EROMAN CHK 8-29-92 B EDWARDS APPD 9-21-92 S GRINDERSLEV	AMP AMP Incorporated Harrisburg, PA 17105-3608 NAME KIT, CONNECTOR, 125µm 2.5mm BAYONET, XTC SINGLEMODE
MATERIAL △	APPD 8-29-92 K MONROE PRODUCT SPEC -	
FINISH △	APPLICATION SPEC -	SIZE C
	WEIGHT -	CAGE CODE 00779
		DRAWING NO C=504000
		SCALE -
		SHEET 1 OF 1

THIS DRAWING IS A CONTROLLED DOCUMENT FOR AMP INCORPORATED. IT IS SUBJECT TO CHANGE AND THE CONTROLLING ENGINEERING ORGANIZATION SHOULD BE CONTACTED FOR THE LATEST REVISION.