

4

3

2

1

THIS DRAWING IS UNPUBLISHED. RELEASED FOR PUBLICATION
 BY TYCO ELECTRONICS CORPORATION. ALL RIGHTS RESERVED.

REV	DATE	BY	APPV
B2	13MAR2009	BB	SB
C	06MAR2010	DLF	CB

⚠ MATERIAL: PROTECTIVE COVER: TPE, COLOR:BLACK, UL 94 V-0. *
 FERRULE SUB ASSEMBLY: ZIRCONIA/METAL.
 COMPRESSION SPRING: STAINLESS STEEL.
 HOUSING: PPSU, COLOR:SEE DASH NO'S.
 INNER TUBING: PTFE, COLOR:CLEAR, UL VW-1.
 REAR BODY:METAL.
 BOOT: PP, COLOR:BLUE, UL 94 V-0. *
 CRIMP EYELET/HEAT SHRINK ASSY: ALUM. ALLOY, HEAT SHRINK: POLYOLEFIN, UL VW-1.
 *RATED AT QUALIFYING THICKNESS.

2. INSTRUCTION SHEET: 408-8675 AVAILABLE FOR DOWNLOAD AT www.tycoelectronics.com/documents
 OR www.ampnetconnect.com/fooguide.

⚠ BLACK DOT SIGNIFIES SINGLEMODE.

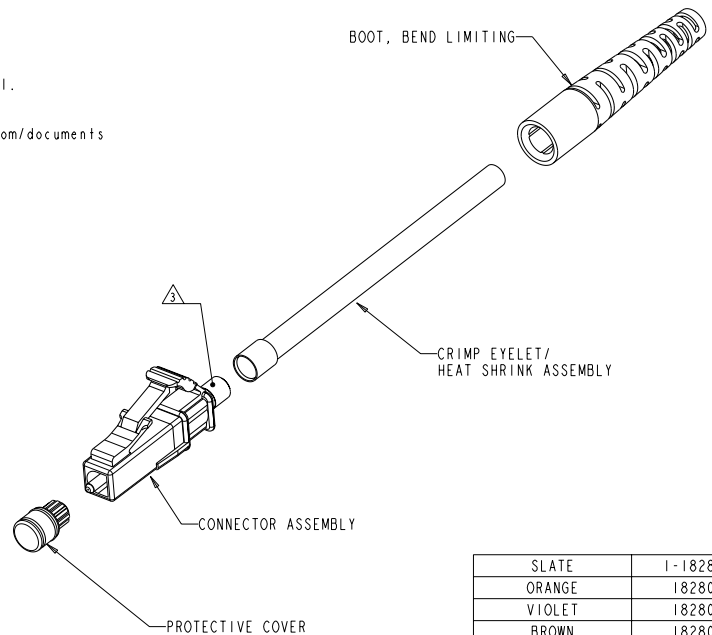
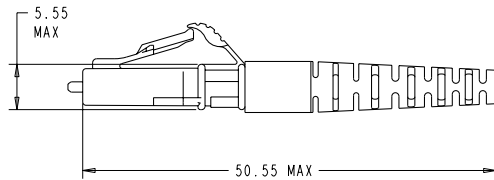
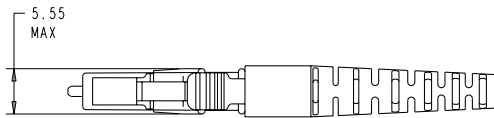

SLATE	1-1828079-0
ORANGE	1828079-9
VIOLET	1828079-8
BROWN	1828079-7
AQUA	1828079-6
ROSE	1828079-5
BLUE	1828079-4
GREEN	1828079-3
YELLOW	1828079-2
RED	1828079-1
COLOR	PART NO

DATE	22FEB2006	OWN	D IERDMAN	22FEB2006	TYCO ELECTRONICS	HARRISBURG, PA 17105-3608
DESIGNED BY	M GURREAN	22FEB2006	APPROVED BY	D BAICHTLE	KIT, CONNECTOR, LC SECURE SIMPLEX, SM, 1.6-2.0mm, JACKET	
DIMENSIONS:	mm	OPERATING SPEC:	0 PLC ±0.1	1 PLC ±0.01	2 PLC ±0.01	3 PLC ±0.01
MATERIAL:	FINISH	WEIGHT:	CUSTOMER DRAWING	SCALE	3:1	SHEET 1 OF 1