

4 3 2 1

THIS DRAWING IS UNPUBLISHED. RELEASED FOR PUBLICATION
 BY TYCO ELECTRONICS CORPORATION. ALL RIGHTS RESERVED.

REV	DATE	BY	CHKD	APPROV
B2	17MAR2009	BB	SB	
C	08MAR2010	DLF	CB	

△ MATERIAL: PROTECTIVE COVER: TPE, COLOR: BLACK, UL 94 V-0. *
 FERRULE SUB ASSEMBLY: ZIRCONIA/METAL.
 COMPRESSION SPRING: STAINLESS STEEL.
 HOUSING: PPSU, COLOR: SEE DASH NO'S.
 INNER TUBING: PTFE, COLOR: CLEAR, UL VW-1.
 REAR BODY: METAL
 BOOT: TPE, COLOR: BEIGE, UL 94 V-0. *
 *RATED AT QUALIFYING THICKNESS.

2. INSTRUCTION SHEET: 408-8675 AVAILABLE FOR DOWNLOAD AT
www.tycoelectronics.com/documents OR www.ampnetconnect.com/foguide.

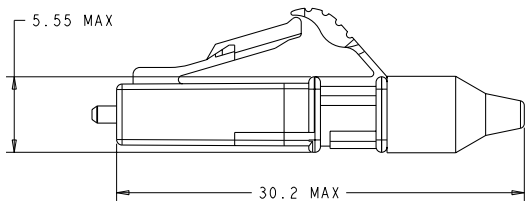
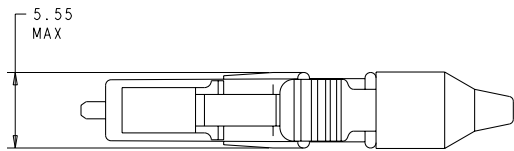
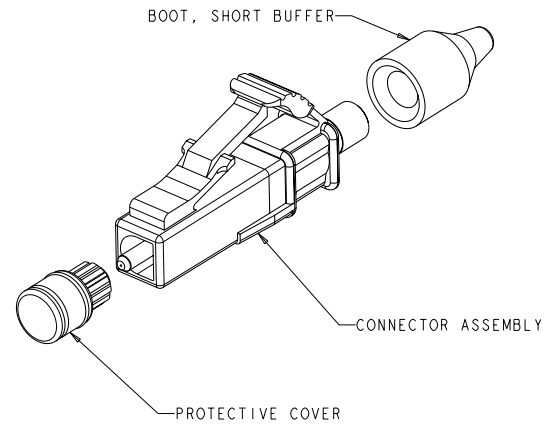

SLATE	1-1828861-0
ORANGE	1828861-9
VIOLET	1828861-8
BROWN	1828861-7
AQUA	1828861-6
ROSE	1828861-5
BLUE	1828861-4
GREEN	1828861-3
YELLOW	1828861-2
RED	1828861-1
COLOR	PART NO

DATE	22FEB2006	DESIGNED BY	D. ERODMAN	DATE	22FEB2006
DATE	22FEB2006	DESIGNED BY	M. GURRARI	DATE	22FEB2006
DATE	22FEB2006	DESIGNED BY	D. BAICHTLE	DATE	22FEB2006
DIMENSIONS: MM/(IN)		OPERATING SPECIFICATIONS		PRODUCT SPEC	
0 PLC		NO. 1/1/0041		APPLICATION SPEC	
1 PLC		NO. 01/1/0041		WEIGHT	
2 PLC		NO.		CUSTOMER DRAWING	
3 PLC		NO.		SCALE 5:1	
4 PLC		NO.		SHEET 1 OF 1	
ANGLES		NO.		REV C	
FINISH		NO.			
MATERIAL		NO.			

Tyco Electronics
 Harrisburg, PA 17105-3608

CONNECTOR KIT, LC, SECURE,
 SIMPLEX, MM, 900um BUFFER

SHEET CASE CODE DRAWING NO
 A2 00779 1828861