

4

3

2

1

THIS DRAWING IS UNPUBLISHED. RELEASED FOR PUBLICATION
 BY TYCO ELECTRONICS CORPORATION. ALL RIGHTS RESERVED.

REV	DATE	BY	CHKD	APPROV
R	08JUN2004	DEH	SAB	
S	18MAR2005	BB	SB	
T	07JUN2005	BB	SB	
TI	18MAR09	JZ	RZ	

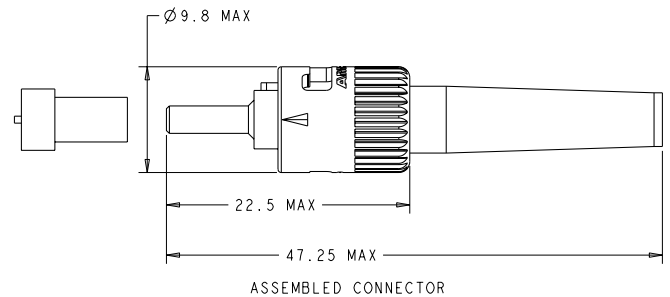
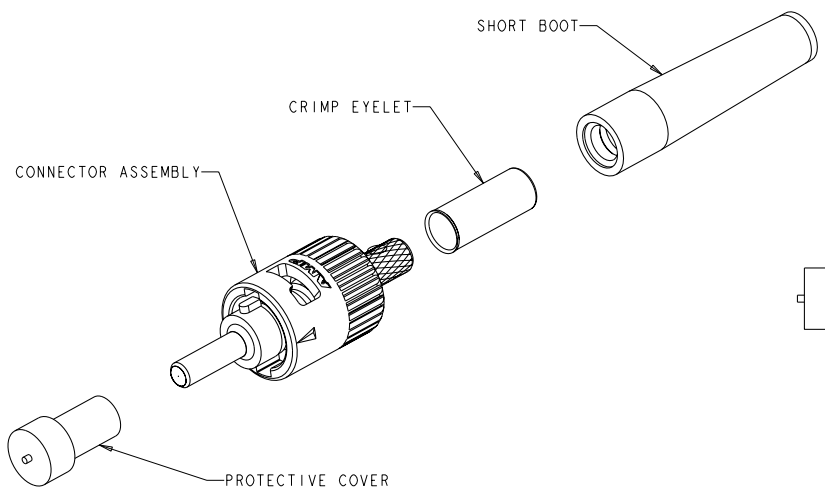

- △ MATERIAL:
- PROTECTIVE COVER: LDPE, COLOR: BLACK, NON-FR.
 - CONNECTOR ASSEMBLY
 - FERRULE ASSEMBLY: PES-GF20, COLOR: WHITE/ARP-GF30, COLOR: BLACK.*
 - SPRING: STAINLESS STEEL
 - COUPLING NUT: PBT-GF17, COLOR: BLACK.*
 - RETENTION RING: STAINLESS STEEL.
 - CRIMP EYELET: TIN PLATED COPPER.
 - SHORT BOOT: TPE, COLOR: BLACK.*
- *UL94 V-0 RATED AT QUALIFYING THICKNESS.

- BULK PACKAGED.
- INSTRUCTION SHEET: 408-9971 AVAILABLE FOR DOWNLOAD AT www.tycoelectronics.com/documents OR www.ampnetconnect.com/foguide.

125	503424-3
FIBER SIZE	PART NUMBER

DIMENSIONS: MM 0 PLC ± 1 PLC ± 2 PLC ± 3 PLC ± 4 PLC ± ANGLES ± MATERIAL FINISH		TOLERANCES UNLESS OTHERWISE SPECIFIED: DECIMALS: ±0.15 FRACTIONS: ±0.005	DWG: D. E. HODGE 08JUN04 CDR: J. HOPKINS 08JUN04 APPR: S. BUCHTER 08JUN04 NAME: S. BUCHTER PRODUCT SPEC: APPLICATION SPEC: WEIGHT: CUSTOMER DRAWING	Tyco Electronics Corporation Shanghai, China CONNECTOR KIT, BAYONET POLYMER COMPOSITE OVERMOLD SHEET: A2 CASE CODE: 00779 DRAWING NO: 503424 RESTRICTED TO:
AMP 1471-9 REV 31MAR2000 Pro/ENGINEER DRAWING			SCALE: 4:1 SHEET 1 OF 1 REV: 1	