

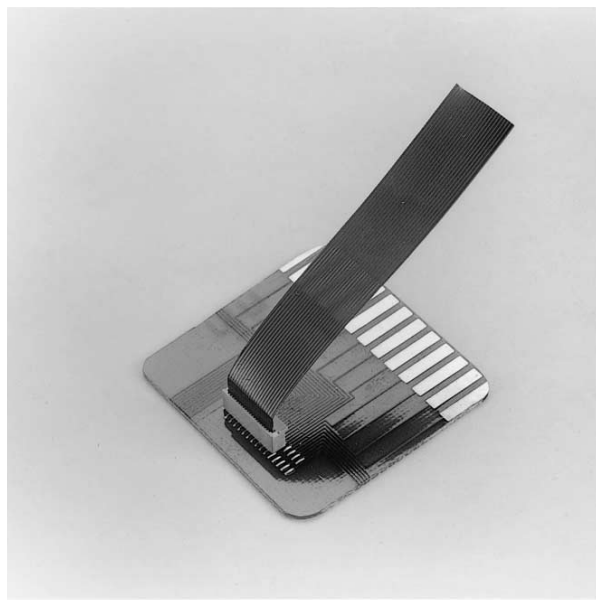

FLT CONNECTOR

Connectors for FPC

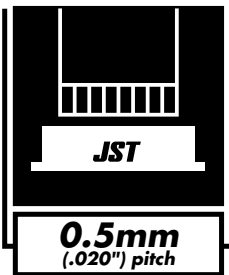

Features

• Heat resistant design suitable for surface mounting

The housing is made of heat resistant plastic to allow reflow soldering.

• Staggered surface mount tails

The lead pitch is thus 1.0mm (.039"), which enables connector mounting operation easier.

• Embossed tape for automatic mounting

The FLT connector is packaged in embossed tape for automatic mounting. The plastic reel can be used repeatedly, good for eco-system.

• FPC insertion is easy

Staggered and unique contact point layout can reduce the FPC insertion force, yet with secure retention force.

• Compact design

This connector measures only 4.15mm (.163") high after mounting, with a reduced surface mounting area, as solder tabs are not necessary because of the staggered solder tail construction.

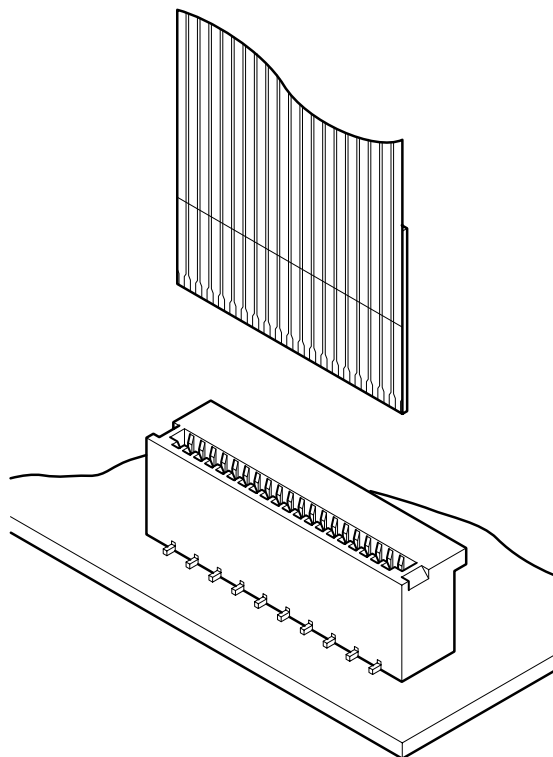

Specifications

- Current rating: 0.5A AC, DC
- Voltage rating: 50V AC, DC
- Temperature range: -25°C to +85°C
(including temperature rise in applying electrical current)
- Contact resistance: Initial value/50m Ω max.
After environmental testing/20m Ω max.
(Variance from the initial)
- Insulation resistance: 500M Ω min.
- Withstanding voltage: 200V AC/minute
- Applicable FPC: Lead pitch/0.5mm (.020")
Lead width/0.35mm (.014")
Mating part thickness/
0.30 ± 0.05mm (.012"±.002")

<Note>FPC to be actually used should be checked for applicability.

* Contact JST if Lead-Free product is required.

* Refer to "General Instruction and Notice when using Terminals and Connectors" at the end of this catalog.

* Contact JST for details.

Standards

Ⓜ Recognized E60389

Ⓢ Certified LR20812

FLT CONNECTOR

Connector

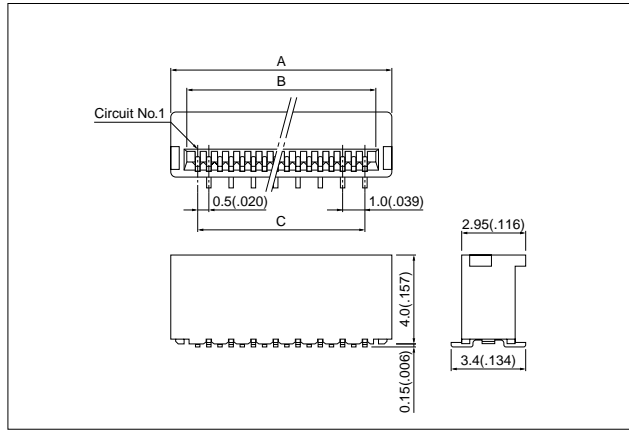

Circuits	Model No.	Dimensions mm(in.)			Q'ty / reel
		A	B	C	
6	06FLT-SM1-TB	4.9(.193)	3.5(.138)	2.5(.098)	2,500
8	08FLT-SM1-TB	5.9(.232)	4.5(.177)	3.5(.138)	2,500
10	10FLT-SM1-TB	6.9(.272)	5.5(.217)	4.5(.177)	2,500
12	12FLT-SM1-TB	7.9(.311)	6.5(.256)	5.5(.217)	2,500
14	14FLT-SM1-TB	8.9(.350)	7.5(.295)	6.5(.256)	2,500
16	16FLT-SM1-TB	9.9(.390)	8.5(.335)	7.5(.295)	2,500
18	18FLT-SM1-TB	10.9(.429)	9.5(.374)	8.5(.335)	2,500
20	20FLT-SM1-TB	11.9(.469)	10.5(.413)	9.5(.374)	2,500
22	22FLT-SM1-TB	12.9(.508)	11.5(.453)	10.5(.413)	2,500
24	24FLT-SM1-TB	13.9(.547)	12.5(.492)	11.5(.453)	2,500
26	26FLT-SM1-TB	14.9(.587)	13.5(.531)	12.5(.492)	2,500
28	28FLT-SM1-TB	15.9(.626)	14.5(.571)	13.5(.531)	2,500
30	30FLT-SM1-TB	16.9(.665)	15.5(.610)	14.5(.571)	2,500
32	32FLT-SM1-TB	17.9(.705)	16.5(.650)	15.5(.610)	2,500
40	40FLT-SM1-TB	21.9(.862)	20.5(.807)	19.5(.768)	2,500

Material and Finish

Contact: Phosphor bronze, copper-undercoated, tin/lead-plated
Housing: Nylon 46, UL94V-0

Note: 1. The products listed above are supplied on embossed-tape.
2. 32FLT-SM1-TB and 40FLT-SM1-TB are not CSA approved.

Taping specifications

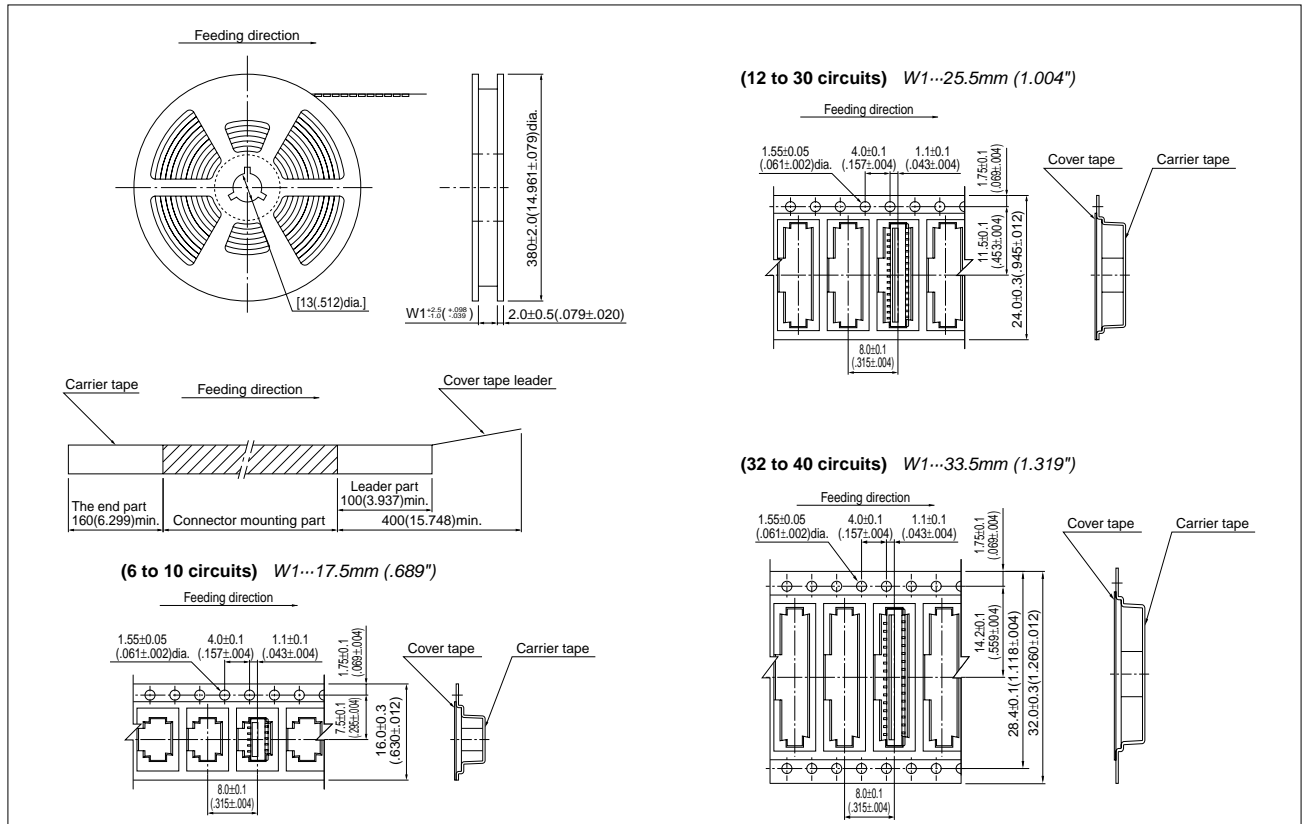

Note:

- Specifications conform to JIS C 0806. The tape width, connector recess hole dimensions, etc. are determined by the number of circuits and external shape of the connector to be loaded.
- Specifications are subject to change without prior notice.

FLT CONNECTOR

Lead section dimensions of FPC

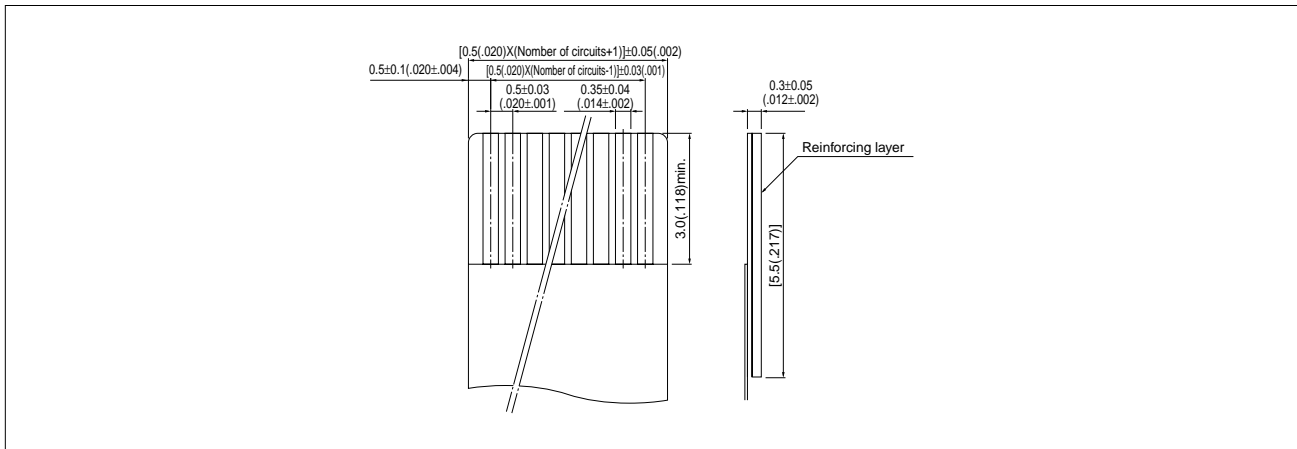

PC board layout (viewed from component side) and Assembly layout

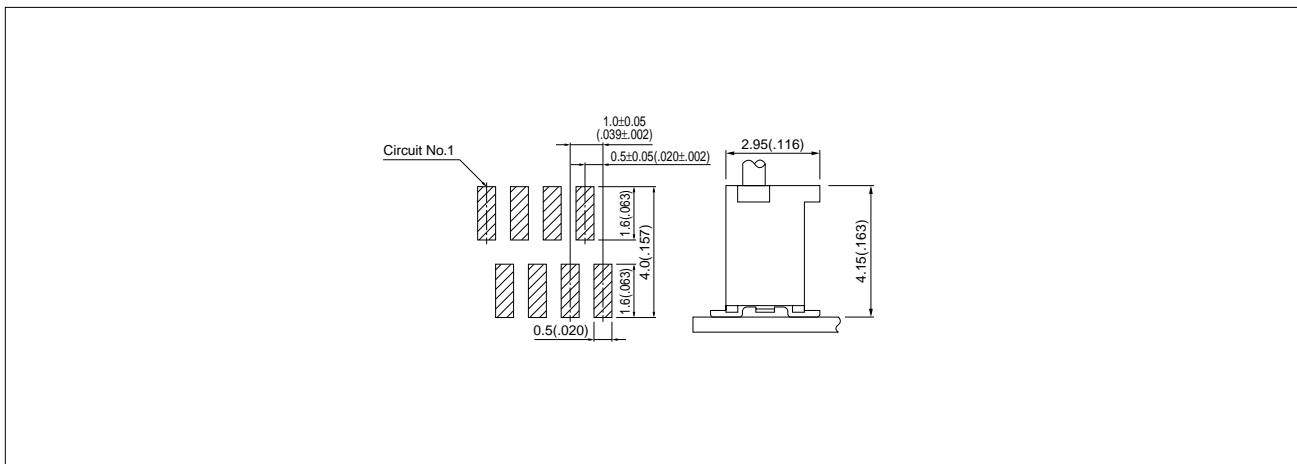

Note:

1. Tolerances are non-cumulative: $\pm 0.05\text{mm}$ ($\pm .002''$) for all centers.
2. The dimensions above should serve as a guide line. Contact JST for details.