

注記 NOTES

1. 使用材料 MATERIAL
 ハウジング HOUSING : 46ナイロン, UL 94V-0
 アクチュエータ ACTUATOR : PPS, UL 94V-0
 ターミナル TERMINAL : リン青銅 (t=0.2), ニッケル下地鍍ピスマスメッキ
 PHOS-BRO,TIN-BISMUTH OVER NICKEL PLATED
 金具 FITTING NAIL : リン青銅 (t=0.2), ニッケル下地鍍メッキ
 PHOS-BRO,TIN OVER NICKEL PLATED
- △ パターンはくり止め用金具
 FITTING NAIL FOR PREVENTION OF PEELING OF P.C.B. PATTERN.
- △ ソルダーテール半田付け面のスレ量、及び金具半田付け面のスレ量は、基準面 Y に対し上方向 0.05 MAX.、下方向 0.2 MAX. とする。
 MISALIGNMENT OF SOLDER TAILS AND FITTING NAILS FROM Y
 UPPER DIRECTION: 0.05 MAX., LOWER DIRECTION: 0.2 MAX.
- △ 偶数極に適用。
 APPLY FOR EVEN CIRCUIT.
5. 本製品は52892-***17の鉛フリー品である。
 THIS PRODUCT IS LEAD FREE OF 52892-***17

| | | | | | | |
|------|------|-------|------|------------|------------|----|
| 19.6 | 15.5 | 14.57 | 14.5 | 52892-3095 | 52892-3019 | 30 |
| 18.6 | 14.5 | 13.57 | 13.5 | -2895 | -2819 | 28 |
| 17.6 | 13.5 | 12.57 | 12.5 | -2695 | -2619 | 26 |
| 16.6 | 12.5 | 11.57 | 11.5 | -2495 | -2419 | 24 |
| 15.6 | 11.5 | 10.57 | 10.5 | -2295 | -2219 | 22 |
| 14.6 | 10.5 | 9.57 | 9.5 | -2095 | -2019 | 20 |
| 14.1 | 10.0 | 9.07 | 9.0 | -1995 | -1919 | 19 |
| 13.6 | 9.5 | 8.57 | 8.5 | -1895 | -1819 | 18 |
| 13.1 | 9.0 | 8.07 | 8.0 | -1795 | -1719 | 17 |
| 12.6 | 8.5 | 7.57 | 7.5 | -1695 | -1619 | 16 |
| 12.1 | 8.0 | 7.07 | 7.0 | -1595 | -1519 | 15 |
| 11.6 | 7.5 | 6.57 | 6.5 | -1495 | -1419 | 14 |
| 11.1 | 7.0 | 6.07 | 6.0 | -1395 | -1319 | 13 |
| 10.6 | 6.5 | 5.57 | 5.5 | -1295 | -1219 | 12 |
| 10.1 | 6.0 | 5.07 | 5.0 | -1195 | -1119 | 11 |
| 9.6 | 5.5 | 4.57 | 4.5 | -1095 | -1019 | 10 |
| 8.6 | 4.5 | 3.57 | 3.5 | 52892-0895 | 52892-0819 | 8 |

| | | | | | | | |
|---|---------------------------------------|--|----------------------------|---|---|------------------------------|------------------------|
| REVISED EC NO: J2008-4308 DRAWN BY: M.NABEI 2008/06/27 CHYKD:THARYAMA 2008/06/30 APPR:NIKIITA 2008/06/30 | GENERAL TOLERANCES (UNLESS SPECIFIED) | | DIMENSION STYLE MM ONLY | | SCALE --- | DESIGN UNITS METRIC | THIRD ANGLE PROJECTION |
| | 10 UNDER | ±0.2 | DRAWN BY M.NABEI | DATE 2004/01/09 | TITLE 0.5 FPC CONN ASSY ZIF SMT RA(BTM CONT) E/O -LEAD FREE- | | |
| | 10 OVER 30 UNDER | ±0.25 | CHECKED BY M.SASAO | DATE 2004/01/09 | MOLEX INCORPORATED | | |
| | 30 OVER | ±0.3 | APPROVED BY M.SASAO | DATE 2004/01/09 | MATERIAL NO. SEE TABLE | DOCUMENT NO. SD-52892-040 | SHEET NO. 1 OF 3 |
| ANGULAR ±3° | | DRAFT WHERE APPLICABLE MUST REMAIN WITHIN DIMENSIONS | | THIS DRAWING CONTAINS INFORMATION THAT IS PROPRIETARY TO MOLEX INCORPORATED AND SHOULD NOT BE USED WITHOUT WRITTEN PERMISSION | | | |

10 9 8 7 6 5 4 3 2 1

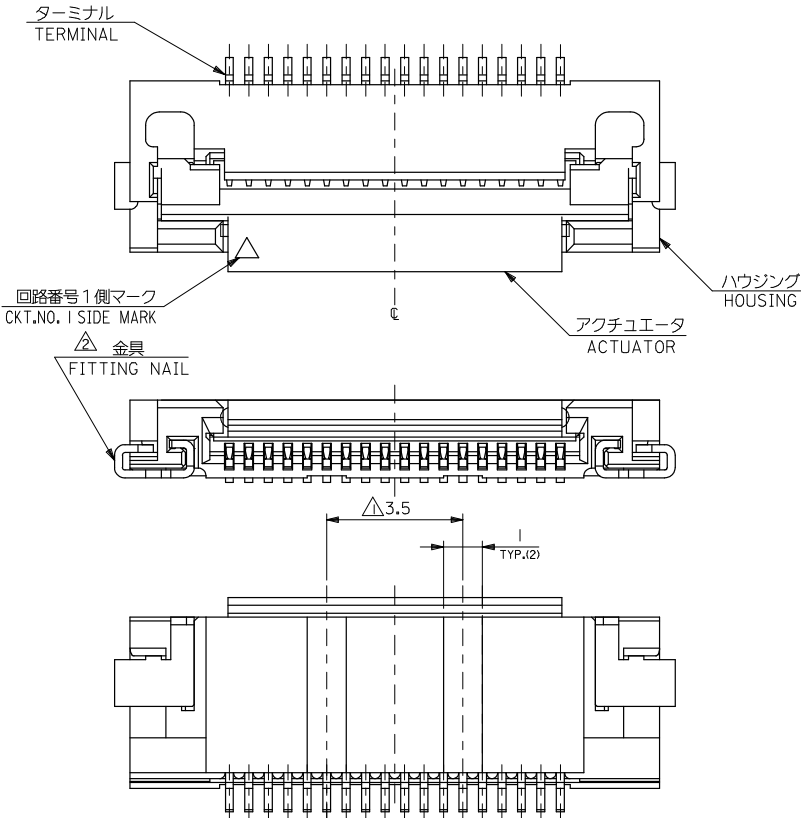

金型変更に伴なう形状変更品形状図
 APPLY CHANGED FORM AT CHANGED DIE

注記 NOTES

△ 18種以上は2ヶ所、10~16種はハウジングセンター上に1ヶ所とする。
 18 CKTS & MORE THAN 18 CKTS PLACED 2 POINT.
 10~16 CKTS PLACED 1 POINT ON HOUSING CENTER.

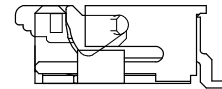

| | | | | | | | |
|---|---------------------------------------|--|----------------------------|--|-----------------------------|--|---------------------|
| REVISED EC NO: J2008-4308 DRAWN: MABEL 2008/06/27 CHKD: THARYAMA 2008/06/30 APPR: NIKITA 2008/06/30 | GENERAL TOLERANCES (UNLESS SPECIFIED) | | DIMENSION STYLE MM ONLY | | SCALE --- | 52892-***19 | MODEL NO. |
| | 10 UNDER | ±0.2 | DRAWN BY M. NABEL | DATE 2004/01/09 | TITLE | 0.5 FPC CONN ASSY ZIF SMT RA(BTM CONT) E/O -LEAD FREE- | |
| | 10 OVER 30 UNDER | ±0.25 | CHECKED BY M. SASAO | DATE 2004/01/09 | MOLEX INCORPORATED | | |
| | 30 OVER | ±0.3 | APPROVED BY M. SASAO | DATE 2004/01/09 | MATERIAL NO. SEE SHEET 1 | DOCUMENT NO. SD-52892-040 | SHEET NO. 3 OF 3 |
| ANGULAR ±3 ° | | DRAFT WHERE APPLICABLE MUST REMAIN WITHIN DIMENSIONS | | THIS DRAWING CONTAINS INFORMATION THAT IS PROPRIETARY TO MOLEX INCORPORATED AND SHOULD NOT BE USED WITHOUT WRITTEN PERMISSION | | | |

10 9 8 7 6 5 4 3 2 1

引き出し方向
PULL OUT
DIRECTION

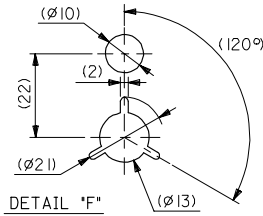
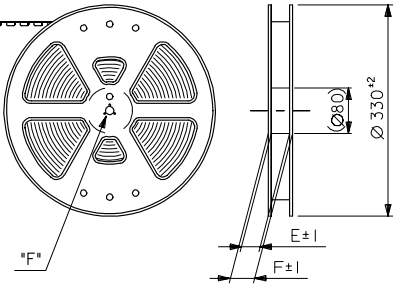

注記 NOTES

- 製品詳細寸法については図面 SD-52892-040 を参照下さい。
RE DETAILED DIMENSION, SEE SD-52892-040
- 梱包数量：1000個/リール
NUMBER OF CONNECTORS : 1000PCS/REEL
- リードテープ長さ LEAD TAPE LENGTH

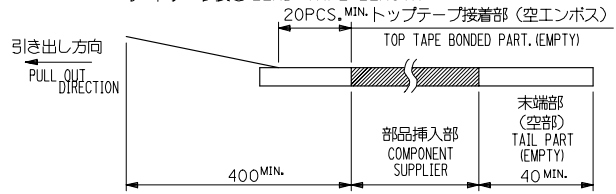

- トップテープの剥離強度： 0.1N ~ 1.3N(10 ~ 130gf)
(剥離方向は下図参照)
尚、本規格値は出荷時に適用。(但し、輸送時に剥離が発生しないこと。)
PEELING OFF FORCE OF TOP TAPE : 0.1N ~ 1.3N(10 ~ 130gf)
(PEELING DIRECTION AS SHOWN IN FOLLOWING FIG.)
THIS REQUIREMENT SHOULD BE APPLIED AT SHIPMENT.
PEEL OFF SHOULD NOT BE ALLOWED , DURING TRANSPORTATION.

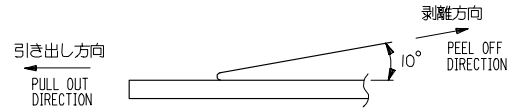

- 材料(MATERIAL)
キャリアテープ(CARRIER TAPE) : ポリプロピレン(POLYPROPYLENE)
トップテープ(TOPTAPE) : PET , PE , PEF
リール(REEL) : ポリスチレン (PS) <リサイクル材を含む>
POLYSTYRENE (PS) <RECYCLE MATERIAL CONTAINED>
- 本製品は52892-**-**90の鉛フリー品である。
THIS PRODUCT IS LEAD FREE OF 52892-**-**90

| | | | | | | | |
|---|---------------------------------------|--|----------------------------|------------------------------|--|------------------------|---------------------------|
| REVISED IEC NO. J2005-1026 DRWN: ISASANDOR CHKDK: TOJO APPR: NIKITA 2004/10/06 2004/10/07 2004/10/12 | GENERAL TOLERANCES (UNLESS SPECIFIED) | | DIMENSION STYLE MM ONLY | | SCALE --- | DESIGN UNITS METRIC | THIRD ANGLE PROJECTION |
| | 10 UNDER | ±0.2 | DRAWN BY M. NABE I | DATE 2004/01/09 | TITLE EMBOSSED TAPE PACKAGE FOR 0.5 FPC CONN. -LEAD FREE- MOLEX INCORPORATED | | |
| | 10 OVER 30 UNDER | ±0.25 | CHECKED BY M. SASAO | DATE 2004/01/09 | | | |
| | 30 OVER | ±0.3 | APPROVED BY M. SASAO | DATE 2004/01/09 | | | |
| ANGULAR | ±3 | MATERIAL NO. 52892-**-**95 | | DOCUMENT NO. SD-52892-041 | SHEET NO. 1 OF 2 | | |
| DRAFT WHERE APPLICABLE MUST REMAIN WITHIN DIMENSIONS | | THIS DRAWING CONTAINS INFORMATION THAT IS PROPRIETARY TO MOLEX INCORPORATED AND SHOULD NOT BE USED WITHOUT WRITTEN PERMISSION | | | | | |

tb_frame_A3_J_ME_S
Rev. D 2004/04/02

9

8

7

6

5

4

3

2

EN-02JA(021)

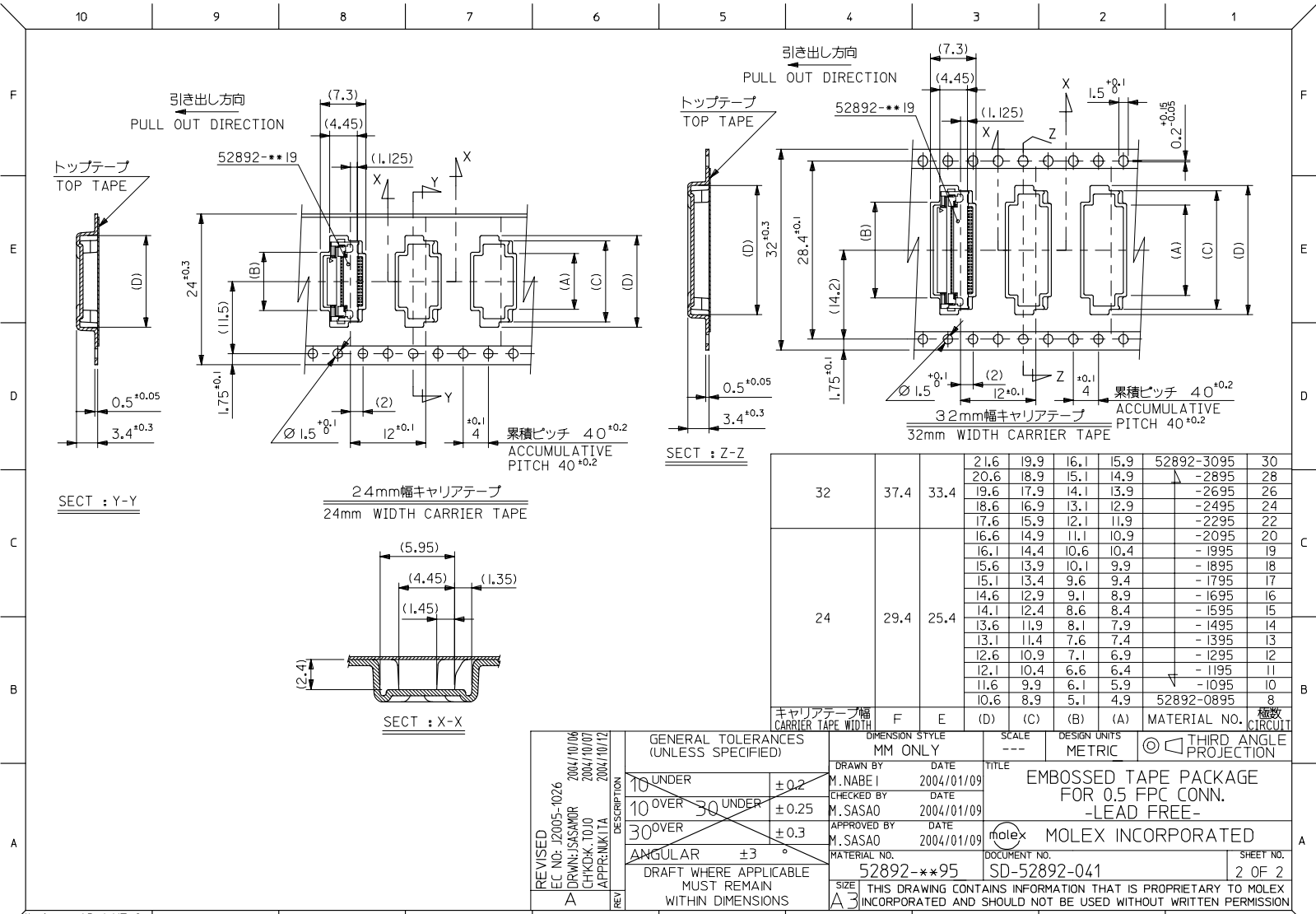

| Carrier Tape Width (mm) | F (mm) | E (mm) | (D) (mm) | (C) (mm) | (B) (mm) | (A) (mm) | Material No. | Pin No. |
|-------------------------|--------|--------|----------|----------|------------|----------|--------------|---------|
| 32 | 21.6 | 19.9 | 16.1 | 15.9 | 52892-3095 | 30 | | |
| | 20.6 | 18.9 | 15.1 | 14.9 | -2895 | 28 | | |
| | 19.6 | 17.9 | 14.1 | 13.9 | -2695 | 26 | | |
| | 18.6 | 16.9 | 13.1 | 12.9 | -2495 | 24 | | |
| | 17.6 | 15.9 | 12.1 | 11.9 | -2295 | 22 | | |
| | 16.6 | 14.9 | 11.1 | 10.9 | -2095 | 20 | | |
| | 16.1 | 14.4 | 10.6 | 10.4 | -1995 | 19 | | |
| | 15.6 | 13.9 | 10.1 | 9.9 | -1895 | 18 | | |
| | 15.1 | 13.4 | 9.6 | 9.4 | -1795 | 17 | | |
| | 14.6 | 12.9 | 9.1 | 8.9 | -1695 | 16 | | |
| 24 | 14.1 | 12.4 | 8.6 | 8.4 | -1595 | 15 | | |
| | 13.6 | 11.9 | 8.1 | 7.9 | -1495 | 14 | | |
| | 13.1 | 11.4 | 7.6 | 7.4 | -1395 | 13 | | |
| | 12.6 | 10.9 | 7.1 | 6.9 | -1295 | 12 | | |
| | 12.1 | 10.4 | 6.6 | 6.4 | -1195 | 11 | | |
| | 11.6 | 9.9 | 6.1 | 5.9 | -1095 | 10 | | |
| | 10.6 | 8.9 | 5.1 | 4.9 | 52892-0895 | 8 | | |
| | | | | | | | | |
| | | | | | | | | |
| | | | | | | | | |

| | | | | | | |
|--|---------------------------------------|--|--------------------|---|------------------------------|---------------------|
| REVISED IEC NO. J2005-1026 DRWN: JSASANDR CHKDK: TOJO APPR: NIKITA 2004/10/06 2004/10/07 2004/10/12 | GENERAL TOLERANCES (UNLESS SPECIFIED) | DIMENSION STYLE MM ONLY | SCALE --- | DESIGN UNITS METRIC | THIRD ANGLE PROJECTION | |
| | 10 UNDER ±0.2 | DRAWN BY M. NABEI | DATE 2004/01/09 | TITLE EMBOSSD TAPE PACKAGE FOR 0.5 FPC CONN. -LEAD FREE- | | |
| | 10 OVER 30 UNDER ±0.25 | CHECKED BY M. SASAO | DATE 2004/01/09 | MOLEX INCORPORATED | | |
| | 30 OVER ±0.3 | APPROVED BY M. SASAO | DATE 2004/01/09 | MATERIAL NO. 52892-***95 | DOCUMENT NO. SD-52892-041 | SHEET NO. 2 OF 2 |
| | ANGULAR ±3 | DRAFT WHERE APPLICABLE MUST REMAIN WITHIN DIMENSIONS | | | | |