

10 9 8 7 6 5 4 3 2 1

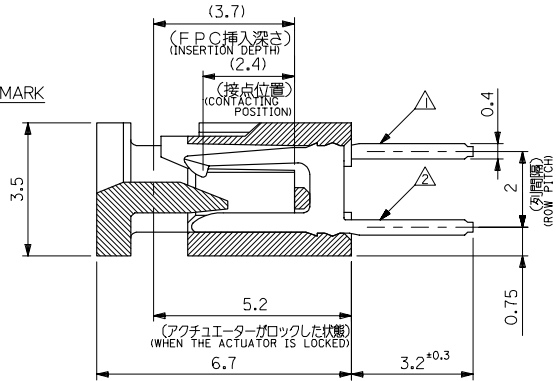
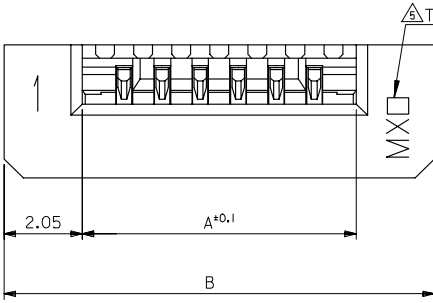

TRADE MARK  
MADE IN JAPAN:MXJ  
MADE IN MALAYSIA:MXL

FPCについて:  
打抜き方向は導体側から補強板側を推奨致します。  
補強フィルム材質はポリイミドを推奨致します。  
接着剤は熱硬化接着剤を推奨致します。

ABOUT FPC:  
RECOMMENDED PUNCHER DIRECTION :FORM CONDUCTOR  
SIDE TO STIFFENER BOARD SIDE.  
RECOMMENDED MATERIAL :  
STIFFENER FILM : POLYIMIDE  
BONDING AGENT : THEROSETTING BONDING AGENT

35.3	31.2	52030-3029	30
34.3	30.2	-2929	29
33.3	29.2	-2829	28
32.3	28.2	-2729	27
31.3	27.2	-2629	26
30.3	26.2	-2529	25
29.3	25.2	-2429	24
28.3	24.2	-2329	23
27.3	23.2	-2229	22
26.3	22.2	-2129	21
25.3	21.2	-2029	20
24.3	20.2	-1929	19
23.3	19.2	-1829	18
22.3	18.2	-1729	17
21.3	17.2	-1629	16
20.3	16.2	-1529	15
19.3	15.2	-1429	14
18.3	14.2	-1329	13
17.3	13.2	-1229	12
16.3	12.2	-1129	11
15.3	11.2	-1029	10
14.3	10.2	-0929	9
13.3	9.2	-0829	8
12.3	8.2	-0729	7
11.3	7.2	-0629	6
10.3	6.2	-0529	5
9.3	5.2	-0429	4
8.3	4.2	52030-0329	3
B	A	MATERIAL NO.	極数 CKT.

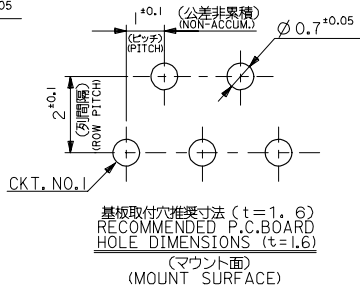
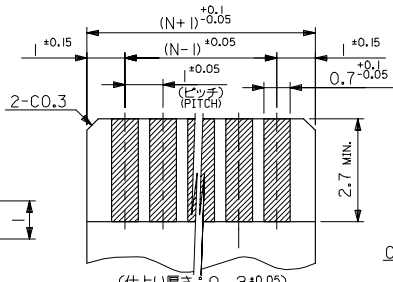
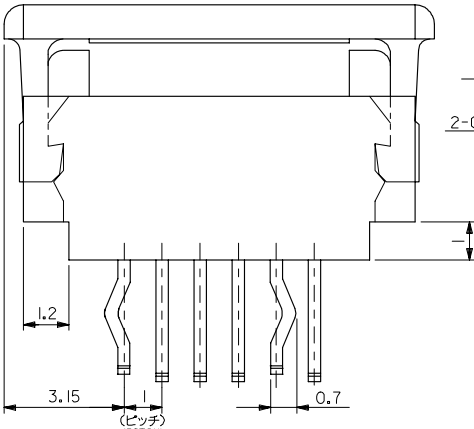

(仕上り厚さ: 0.3+0.05)  
(THICKNESS: 0.3+0.05)  
適合FPC推奨寸法  
APPLICABLE FPC  
RECOMMENDED DIM.

基板取付穴推奨寸法 (t=1.6)  
RECOMMENDED P.C.BOARD  
HOLE DIMENSIONS (t=1.6)  
(マウント面)

注記: △ CKT. NO. 1を基準に偶数番目のソルダーテール。  
EVEN NUMBER SOLDER TAIL.  
△ CKT. NO. 1を基準に奇数番目のソルダーテール。  
ODD NUMBER SOLDER TAIL.  
3. 材料:  
MATERIAL:  
ターミナル: リン青銅、ニッケル下地、銅ヒスマスメッキ (t=0.32)  
TERMINAL: PHOSPHOR BRONZE, TIN-BISMUTH OVER NICKEL PLATING. (t=0.32)  
ハウジング: 66ナイロン、UL94V-0  
HOUSING: 66NYLON, UL94V-0  
アクチュエーター: ポリエステル、UL94V-0  
ACTUATOR: POLYESTER, UL94V-0  
4. 本製品は52030-\* \* 10の鉛フリー品である。  
THIS PRODUCT IS LEAD FREE OF 52030-\* \* 10.

REVISED EC NO: J2008-1613 2007/10/30 DRAWN: A0YAGI CHKD: THIRUYANA 2007/10/30 APPR: NUKITA 2007/10/30	GENERAL TOLERANCES (UNLESS SPECIFIED)		DIMENSION STYLE MM ONLY		SCALE 10:1	DESIGN UNITS METRIC	THIRD ANGLE PROJECTION
	10 UNDER	±0.2	DRAWN BY YWADA	DATE '04/03/29	TITLE 1.0 FPC CONN ZIF ST		
	10 OVER 30 UNDER	±0.25	CHECKED BY MSASAO	DATE '04/03/29	-LEAD FREE-		
	30 OVER	±0.3	APPROVED BY MSASAO	DATE '04/03/29	MOLEX INCORPORATED		
	ANGULAR ±3 °	DRAFT WHERE APPLICABLE MUST REMAIN WITHIN DIMENSIONS		MATERIAL NO. SEE TABLE	DOCUMENT NO. SD-52030-017	SHEET NO. 1 OF 1	