

# 0.5 mm Pitch, 2.55 mm above the board, Flexible Printed Circuit & Flexible Flat Cable ZIF Connectors

## FH28 Series

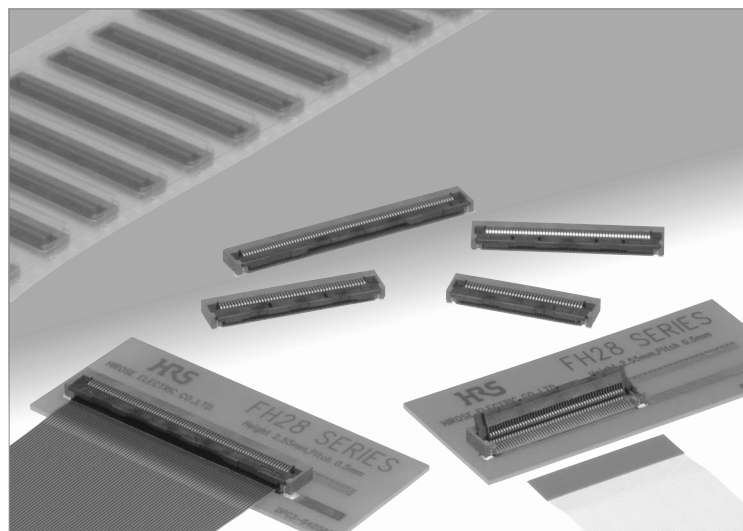

### Secure actuator lock and retention

Hold in place by metal fittings

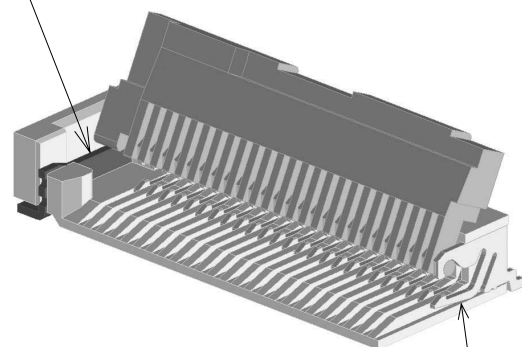

Hold in place by contacts

### ■ Overview

Continuing market trends demand higher contact count connectors while maintaining high electrical/mechanical reliability, exact FPC/FFC positioning and durability.

### ■ Features

#### 1. Precise FFC/FPC positioning

Large angle of the actuator opening and built-in side guides in the connector allow straight and exact insertion of the FPC / FFC.

#### 2. Rotating actuator

Proven rotating actuator system allows easy ZIF connection, confirming it with a definite tactile feel. The contact securely holds the actuator in place, providing reliable normal force. The unique contact configuration assures that the connector will remain dimensionally stable over the device's life.

#### 3. Strong FFC / FPC retention force

Horizontal direction FFC / FPC retention force : Increased 200% (as compared with FH12 series)(30 pos.)

#### 4. Accepts standard FPC/FFC thickness

0.3mm thick standard Flexible Printed Circuit (FPC) and Flexible Flat cable (FFC) can be used.

#### 5. Conductive traces on the PCB can run under the connector

No exposed contacts on the bottom of the connector.

#### 6. Board placement with automatic equipment

Flat upper surface and tape and reel packaging facilitate vacuum pick-up and placement.

Standard reel packaging contains 2,000 connectors.

#### 7. Halogen-free \*

\*As defined by IEC61249-2-21

Br-900ppm maximum, Cl-900ppm maximum,

Cl + Br combined-1,500ppm maximum

#### 8. Optional 500 piece reel packaging

Standard packaging is 2,000 pieces per reel; however, 500 piece reels are possible.

(Emboss reel external diameter is 330mm.)

### FPC temporary hold protrusion

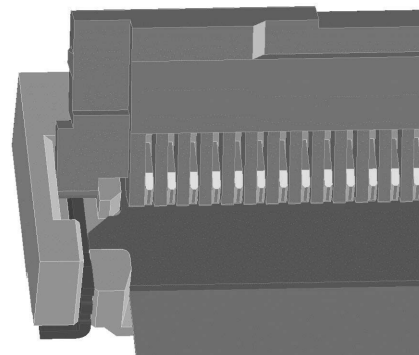

### Support straight type FPC / FFC

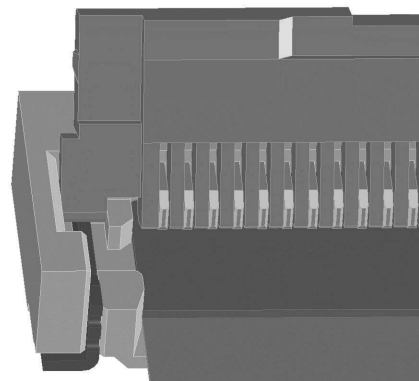

## ■Product Specifications

Rating	Rated current 0.5A DC(Note.1) Rated voltage 50V AC	Operating temperature range-40°C to +85°C(Note 2) Operating humidity rangeRelative humidity 90% max. (No condensation)	Storage temperature range -10°C to +50°C (Note 3) Storage humidity range Relative humidity 90% max
--------	---	--	---

Recommended FPC/FFC	Thickness: = 0.3 ± 0.05mm Gold plated contact traces
---------------------	--

Item	Specification	Conditions
1.Insulation resistance	500 MΩ min	100 V DC
2.Withstanding voltage	No flashover or insulation breakdown.	150 V AC /one minute
3.Contact resistance	50 mΩ max. * Including FPC/FFC conductor resistance	1 mA (DC or 1000Hz)
4.Durability (insertion/ withdrawal)	Contact resistance: 50 mΩ max. No damage, cracks, or parts dislocation.	20 cycles
5.Vibration	No electrical discontinuity of 1μs or more. Contact resistance: 50 mΩ max. No damage, cracks, or parts dislocation.	Frequency: 10 to 55 Hz, single amplitude of 0.75 mm, 10 cycles in each of the 3 directions.
6.Shock	No electrical discontinuity of 1μs. min. Contact resistance: 50 mΩ max. No damage, cracks, or parts dislocation.	Acceleration of 981 m/s <sup>2</sup> , 6 ms duration, sine half-wave waveform, 3 cycles in each of the 3 axis.
7.Humidity (Steady state)	Contact resistance: 50 mΩ max. Insulation resistance: 50 MΩ min. No damage, cracks, or parts dislocation.	96 hours at temperature of 40°C and humidity of 90% to 95%.
8.Temperature cycle	Contact resistance: 50 mΩ max. Insulation resistance: 50 MΩ min. No damage, cracks, or parts looseness.	Temperature: -40°C→+15°C to+35°C→+85°C→+15°C to +35°C Time: 30→2 to 3→30→2 to 3 (Minutes) 5 cycles
9.Resistance to soldering heat	No deformation of components affecting performance.	Reflow: At the recommended temperature profile Manual soldering: 350°C ± 5°C for 5 seconds

Note 1: When passing the current through all of the contacts,use 70% of the current rating.

Note 2: Includes temperature rise caused by current flow.

Note 3: The term "storage" refers to products stored for long period of time prior to mounting and use. Operating Temperature Range and Humidity range covers non- conducting condition of installed connectors in storage, shipment or during transportation.

Note.4: Information contained in this catalog represents general requirements for this Series. Contact us for the drawings and specifications for a specific part number shown.

## ■Materials / Finish

Part	Material	Finish	Remarks
Insulator	LCP	Color: Gray	UL94V-0
Actuator	LCP	Color: Black	
Contacts	Phosphor bronze	Gold plated	—
Metal fittings	Brass	Tin plated	—

## ■Ordering information

**FH 28 D - 50S - 0.5 SH (05)**  

①
②
③
④
⑤
⑥
⑦

① Series name : FH	⑥ Termination type : SMT horizontal mounting type ⑦ specifications (05)...Gold plated,2,000 pieces / reel (10)...Partial gold plated,2,000 pieces / reel (07)...Gold plated(only 40pos.),2,000 pieces / reel (98)...Gold plated,500 pieces / reel
② Series No. : 28	
③ Blank,D : Standard H : Space saving type	
④ Number of positions : 10 to 80	
⑤ Contact pitch : 0.5mm	

## ■ Connector Dimensions

Standard type

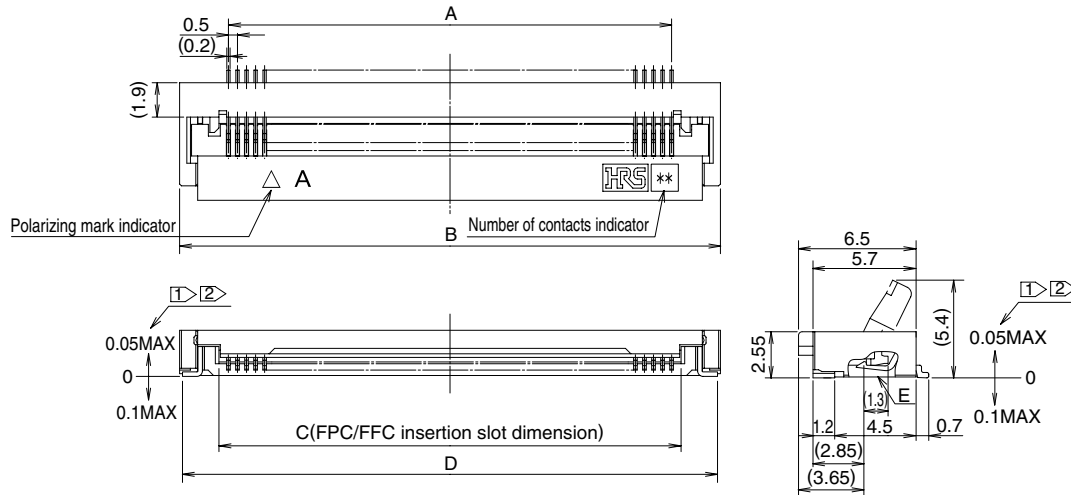

### Notes

- ① The coplanarity of each terminal lead is within 0.1.
- ② The contact terminal lead position indicates the dimension from the E surface, the bottom surface of the insulator body.
- 3 Packaged on tape and reel only. Check packaging specification.
- 4 Sight variations in color of the plastic compounds do not affect form, fit or function.
- 5 After reflow, the terminal plating may change color, however this does not represent a quality issue.

Unit: mm

Part Number	CL No.	Number of contacts	A	B	C	D
FH28-10S-0.5SH(**)	CL586-1861-4-***	10	4.5	9.9	5.57	9.58
FH28-15S-0.5SH(**)	CL586-1868-3-***	15	7	12.4	8.07	12.08
FH28D-20S-0.5SH(**)	CL586-1823-5-***	20	9.5	14.9	10.57	14.58
FH28D-28S-0.5SH(**)	CL586-1835-4-***	28	13.5	18.9	14.57	18.58
FH28D-30S-0.5SH(**)	CL586-1827-6-***	30	14.5	19.9	15.57	19.58
FH28-40S-0.5SH(**)	CL586-1803-8-***	40	19.5	24.9	20.57	24.58
FH28-45S-0.5SH(**)	CL586-1848-6-***	45	22	27.4	23.07	27.08
FH28D-50S-0.5SH(**)	CL586-1808-1-***	50	24.5	29.9	25.57	29.58
FH28D-55S-0.5SH(**)	CL586-1821-0-***	55	27.0	32.4	28.07	32.08
FH28-60S-0.5SH(**)	CL586-1811-6-***	60	29.5	34.9	30.57	34.58
FH28D-64S-0.5SH(**)	CL586-1813-1-***	64	31.5	36.9	32.57	36.58
FH28D-68S-0.5SH(**)	CL586-1819-8-***	68	33.5	38.9	34.57	38.58
FH28D-74S-0.5SH(**)	CL586-1828-9-***	74	36.5	41.9	37.57	41.58

Note 1: Tape and reel packaging.  
Order by number of reels.

Note 2: Metal fittings protruded type (FH28E) is available.  
Contact Hirose for details.

Note 3: \*\*Indicates the specification. For details, please refer to ordering information.

### Space saving type

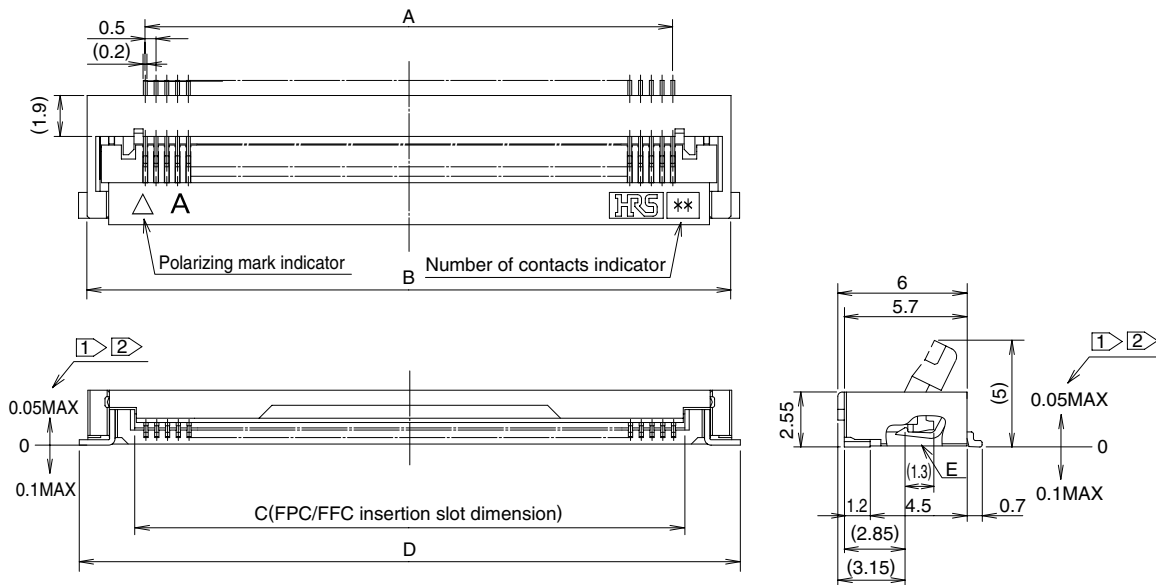

#### Notes

- ① The coplanarity of each terminal lead is within 0.1.
- ② The contact terminal lead position indicates the dimension from the E surface, the bottom surface of the insulator body.
- 3 Packaged on tape and reel only. Check packaging specification.
- 4 Sight variations in color of the plastic compounds do not affect form, fit or function.
- 5 After reflow, the terminal plating may change color, however this does not represent a quality issue.

Unit: mm

Part Number	CL No.	Number of contacts	A	B	C	D
FH28H-80S-0.5SH(**)	586-1805-3-***	80	39.5	44.9	40.57	45.7

Note1: Tape and reel packaging.

Order by number of reels.

Note2: \*\*Indicates the specification. For details, please refer to ordering information.

## Recommended PCB mounting pattern and metal mask dimensions

Recommended metal mask thickness: 0.15 mm.

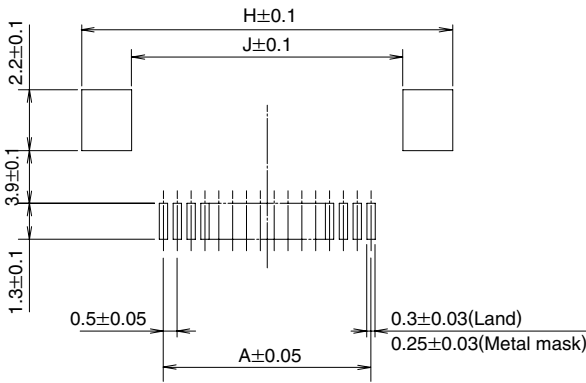

Standard type(FH28, FH28D)

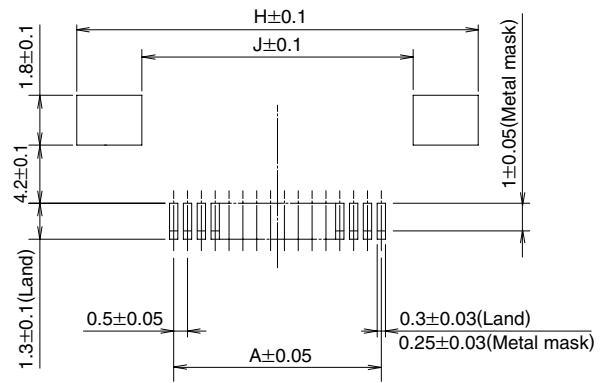

Space saving type(FH28H)

## Recommended FPC/FFC dimensions

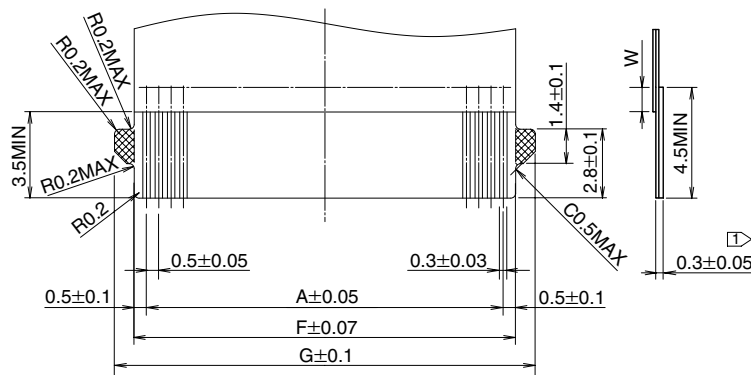

### Notes

- ① Straight type FPC / FFC does not have the side-protruding retention tabs (cross-hatched areas).
- 2 W dimension should be 3.5mm min.

Unit: mm

Part Number	CL No.	Number of contacts	F	G	H	J
FH28-10S-0.5SH(**)	CL586-1861-4-**-	10	5.5	7.1	10.6	7
FH28-15S-0.5SH(**)	CL586-1868-3-**-	15	8	9.6	13.1	9.5
FH28D-20S-0.5SH(**)	CL586-1823-5-**-	20	10.5	12.1	15.6	12.0
FH28D-28S-0.5SH(**)	CL586-1835-4-**-	28	14.5	16.1	19.6	16.0
FH28D-30S-0.5SH(**)	CL586-1827-6-**-	30	15.5	17.1	20.6	17.0
FH28-40S-0.5SH(**)	CL586-1803-8-**-	40	20.5	22.1	25.6	22.0
FH28-45S-0.5SH(**)	CL586-1848-6-**-	45	23	24.6	28.1	24.5
FH28D-50S-0.5SH(**)	CL586-1808-1-**-	50	25.5	27.1	30.6	27.0
FH28D-55S-0.5SH(**)	CL586-1821-0-**-	55	28.0	29.6	33.1	29.5
FH28-60S-0.5SH(**)	CL586-1811-6-**-	60	30.5	32.1	35.6	32.0
FH28D-64S-0.5SH(**)	CL586-1813-1-**-	64	32.5	34.1	37.6	34.0
FH28D-68S-0.5SH(**)	CL586-1819-8-**-	68	34.5	36.1	39.6	36.0
FH28D-74S-0.5SH(**)	CL586-1828-9-**-	74	37.5	39.1	42.6	39.0
FH28H-80S-0.5SH(**)	CL586-1805-3-**-	80	40.5	42.1	46.7	42.0

## ■FH28 Series FPC Construction (Recommended Specifications)

### 1. Using Single-sided FPC

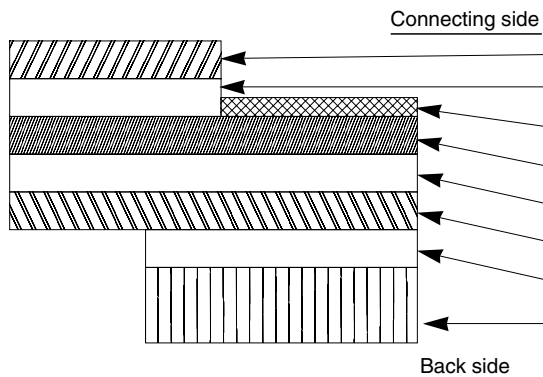

### FPC : Flexible Printed Circuit

Material Name	Material	Thickness (μm)
Covering film layer.	Polyimide 1 mil thick.	25
Cover adhesive		25
Surface treatment	0.2μm thick gold plated over 1 to 5μm thick nickel underplating	3
Copper foil	Cu 1oz	35
Base adhesive		25
Base film	Polyimide 1 mil thick	25
Reinforcement material adhesive	Thermosetting adhesive	30
Stiffener	Polyimide 3 mil thick	175
Total		293

### 2. Using Double-sided FPC

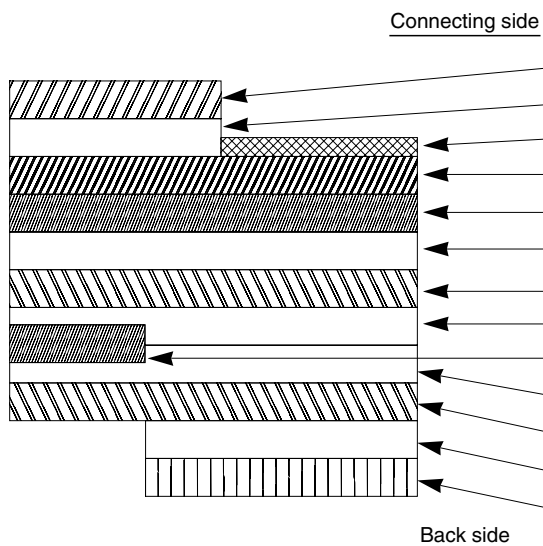

### FPC : Flexible Printed Circuit

Material Name	Material	Thickness (μm)
Covering layer film	Polyimide 1 mil thick	
Cover adhesive		
Surface treatment	0.2μm thick gold plated over 1 to 5μm thick nickel underplating	3
Through-hole copper	Cu	15
Copper foil	Cu 1/2oz	18
Base adhesive		18
Base film	Polyimide 1 mil thick	25
Base adhesive		18
Copper foil	Cu 1/2oz	18
Cover adhesive		25
Covering layer film	Polyimide 1 mil thick	25
Reinforcement material adhesive	Thermosetting adhesive	50
Stiffener	Polyimide 1 mil thick	100
Total		297

\* To prevent release of the lock due to FPC bending, use of the FPC with copper foil on the back side is NOT RECOMMENDED.

### 3. Using FFC

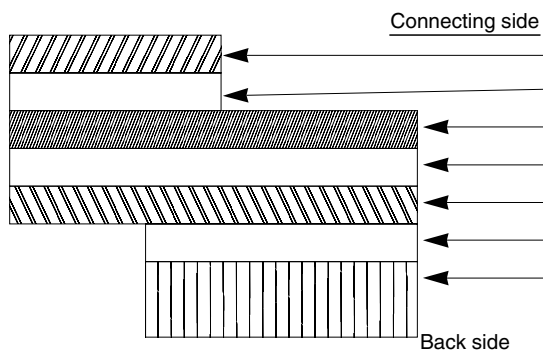

### FFC : Flexible Flat Cable

Material Name	Material	Thickness (μm)
Polyester film		12
Adhesive	Thermoplastic polyester	30
Gold plated annealed copper foil		35
Adhesive	Polyester	30
Polyester		12
Adhesive	Polyester	30
Stiffener	Polyester	188
Total		295

### 4. Precautions

1. This specification is a recommendation for the construction of the FH28 Series FPC and FFC (t=0.3 ± 0.05).
2. For details about the construction, please contact the FPC/FFC manufacturers.

## ■ Packaging specification

### ● Embossed carrier tape dimensions

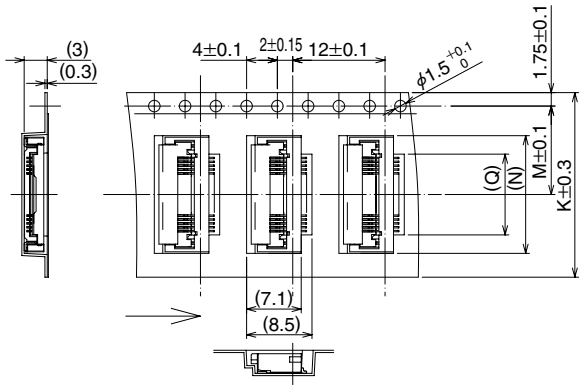

Standard (FH28, FH28D)

### ● Embossed carrier tape dimensions

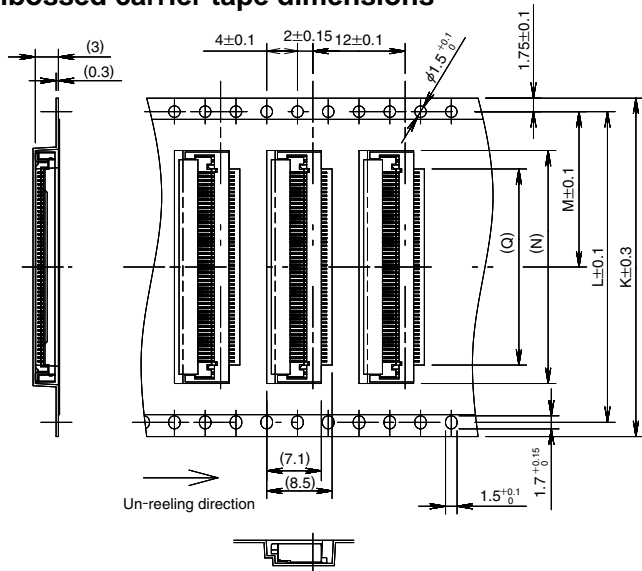

Standard (FH28, FH28D)

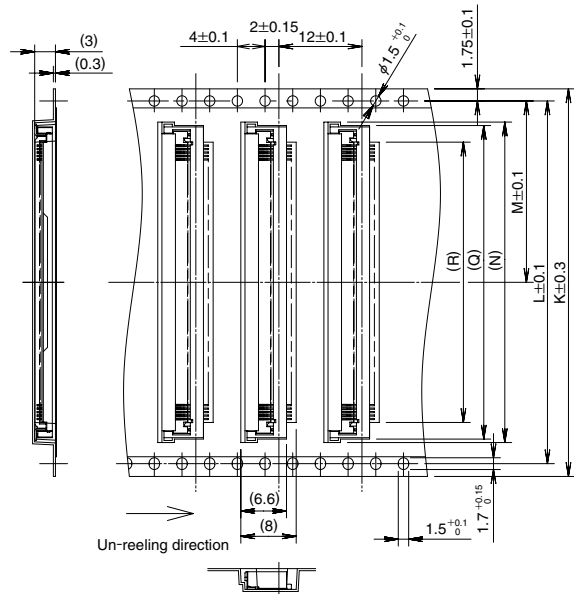

Space saving type (FH28H)

### ● Reel Dimensions

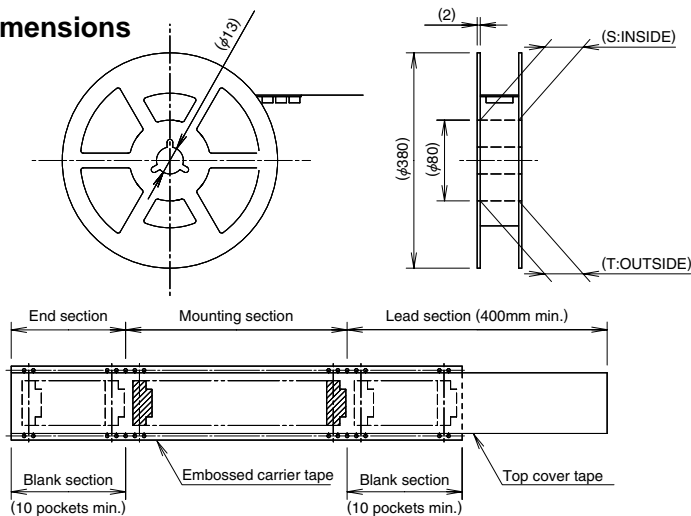

**Standard (FH28,FH28D)**

Unit: mm

Part Number	CL No.	Number of contacts	K	L	M	N	Q	S	T
FH28-10S-0.5SH(**)	CL586-1861-4-***	10	24	—	11.5	10.3	5.5	25.4	29.4
FH28-15S-0.5SH(**)	CL586-1868-3-***	15	24	—	11.5	8.8	8	25.4	29.4
FH28D-20S-0.5SH(**)	CL586-1823-5-***	20	24	—	11.5	15.3	10.5	25.4	29.4
FH28D-28S-0.5SH(**)	CL586-1835-4-***	28	32	28.4	14.2	19.3	14.5	33.4	37.4
FH28D-30S-0.5SH(**)	CL586-1827-6-***	30	32	28.4	14.2	20.3	15.5	33.4	37.4
FH28-40S-0.5SH(**)	CL586-1803-8-***	40	44	40.4	20.2	25.3	20.5	33.4	37.4
FH28-45S-0.5SH(**)	CL586-1848-6-***	45	44	40.4	20.2	27.8	23	45.4	49.4
FH28D-50S-0.5SH(**)	CL586-1808-1-***	50	44	40.4	20.2	30.3	25.5	45.4	49.4
FH28D-55S-0.5SH(**)	CL586-1821-0-***	55	44	40.4	20.2	32.8	28.0	45.4	49.4
FH28-60S-0.5SH(**)	CL586-1811-6-***	60	56	52.4	26.2	35.3	30.5	57.4	61.4
FH28D-64S-0.5SH(**)	CL586-1813-1-***	64	56	52.4	26.2	37.3	32.5	57.4	61.4
FH28D-68S-0.5SH(**)	CL586-1819-8-***	68	56	52.4	26.2	39.3	34.5	57.4	61.4
FH28D-74S-0.5SH(**)	CL586-1828-9-***	74	56	52.4	26.2	43.3	42.3	57.4	61.4

**Space saving type (FH28H)**

Unit: mm

Part Number	CL No.	Number of contacts	K	L	M	N	Q	R	S	T
FH28H-80S-0.5SH(**)	CL586-1805-3-***	80	56	52.4	26.2	46.3	45.3	40.5	57.4	61.4



## ■ Recommended Temperature Profile

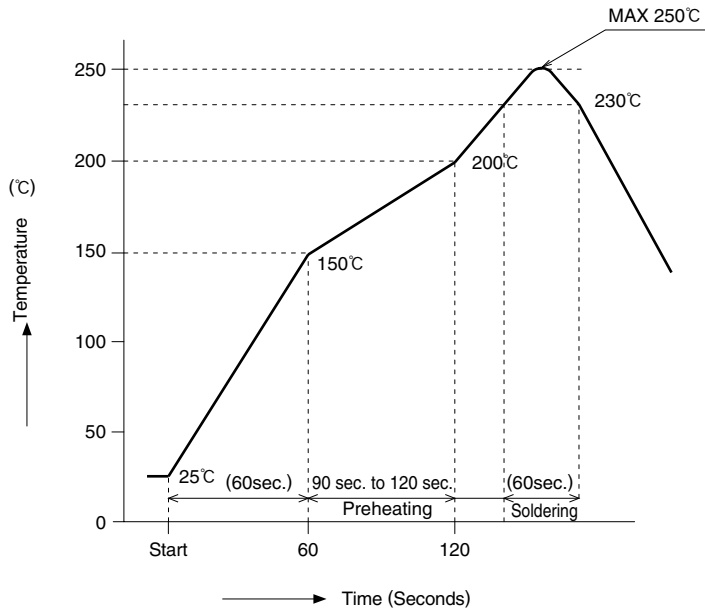

### HRS test condition

Solder method :Reflow, IR

Solder composition :Paste, 96.5%Sn/3.0%Ag/0.5%Cu  
(Senju Metal Industry, Co., Ltd.'s Part  
Number:M705-221CM5-32-10.5)

Test board :Glass epoxy

55mm×150mm×1.6mm thick

Land,Metal mask dimensions : Our recommendations

The temperature profiles are based on the above conditions.

In individual applications the actual temperature may vary, depending on solder paste type, volume/thickness and board size/thickness. Consult your solder paste and equipment manufacturer for specific recommendations.

## ■ Operation and Precautions

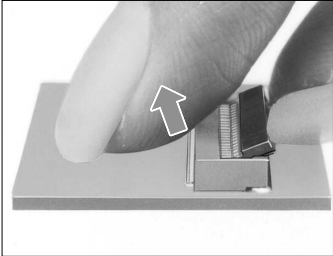
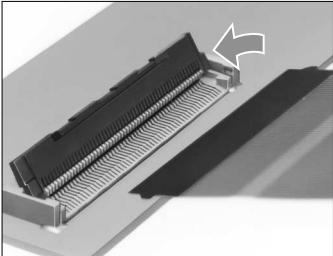
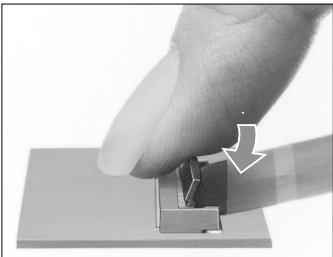
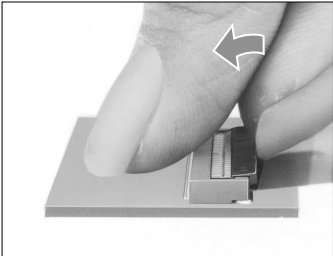
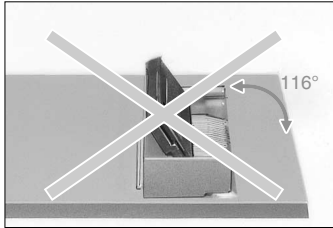
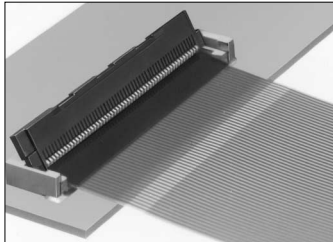
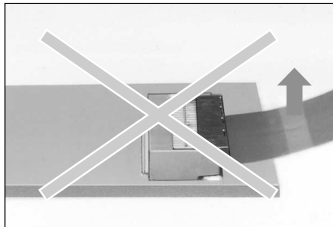
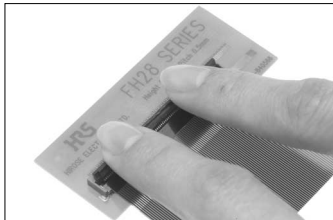
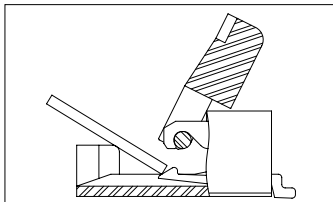
Operation	Precautions
<p><b>1.FPC/FFC insertion procedure.</b>  <b>Connector installed on the board.</b></p> <p>① Lift up the actuator. Use thumb or index finger</p>  <p>② Fully insert the FPC in the connector parallel to mounting surface, with the exposed conductive traces facing down.</p>  <p>③ Rotate down the actuator until firmly closed. It is critical that the inserted FPC/FFC is not moved and remains fully inserted.</p>  <p><b>2.FPC/FFC removal</b>  Fully open the actuator.  Carefully withdraw the FPC/FFC exercising caution not to deform or damage it.</p> 	<p>① Do not force the actuator to open beyond its fully open position. Do not use any type of tool to open the actuator.</p>  <p>② Properly insert the FPC at the positioning part of the connector. Locking the FPC while it is partially inserted, may cause lock damage, disconnection of the FPC, or continuity fault.</p>  <p>③ Do not forcefully bend the FFC/FPC upward. Consult FFC/FPC manufacturer for the recommended bend radiuses.</p>  <p>④ For connectors with multiple contacts, such as 80 pos. rotate down the actuator pushing at both ends.</p>  <p>⑤ Application of excessive force to the inserted FPC/FFC may cause damage to connector and may affect the reliability of electrical connection. If specific application requires continuous or repeated pull or bend of the inserted FPC/FFC, assure that the forces are NOT transmitted directly to the connector.</p> 

## ■ Precautions (mating/un-mating FPC with the retention tabs)

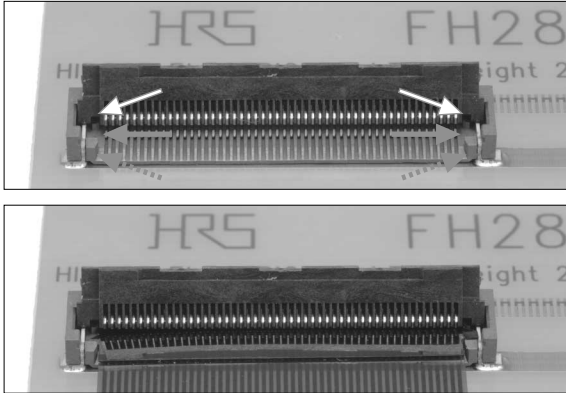
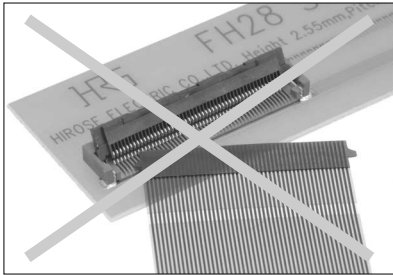
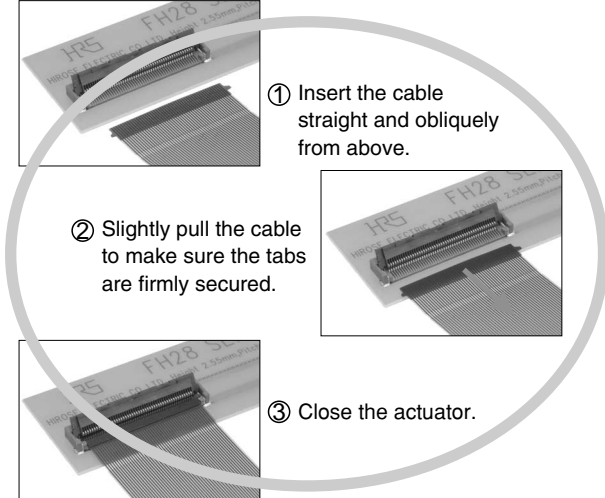
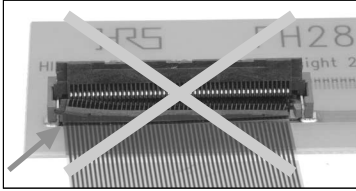
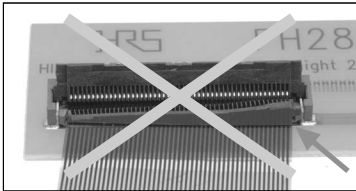
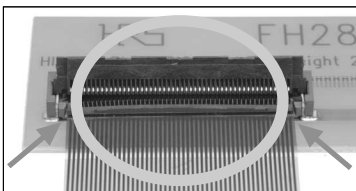
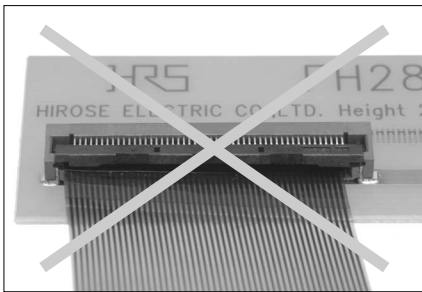
Operation	Precautions
<p><b>1. How to insert</b></p> <p>Insert the cable into the interspace between the mold walls (.....&gt;) at both ends of entrance where the connector is inserted and the guide walls (=&gt;) at both ends of interior connector so the cable tabs are properly located.</p>  <p><b>2. Precautions when mating /un-mating</b></p> <p><b>① Avoid insertion in diagonal direction.</b> Do not insert the cable in diagonal direction. A part of the connector may touch the contacts resulting in deformation of the contacts.</p>  <p>Insert the cable straight into the connector and hook the cable tabs with the guide. After insertion, slightly pull the cables to make sure the cable tabs are firmly secured. No removal of the cable means correct insertion.</p>  <p><b>② Avoid "ride on"</b> Avoid insertion so the cables ride on any guide. Be sure NOT to close the actuator as the cables ride on any guide. It may cause conduction failure.</p> <p>Ride on a left guide</p>  <p>Ride on a right guide</p>  <p>Correct insertion</p>  <p>Do not close the actuator as the cables ride on.</p>  <p>In the event it is locked as the cables ride on a guide, absolutely avoid moving the cable. In this case, open the actuator and re-insert the cable as instructed in "1. How to insert".</p> <p>Do not move the cables back and forth and around as the cables ride on the guide when the actuator is closed.</p> 