

REV	DATE	DESCRIPTION	BY	CHK	APP
DF	DO				
M		REV PER EC 0414-0277-02			

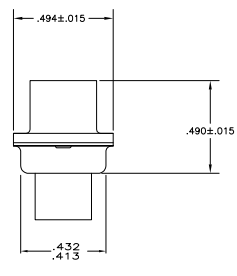
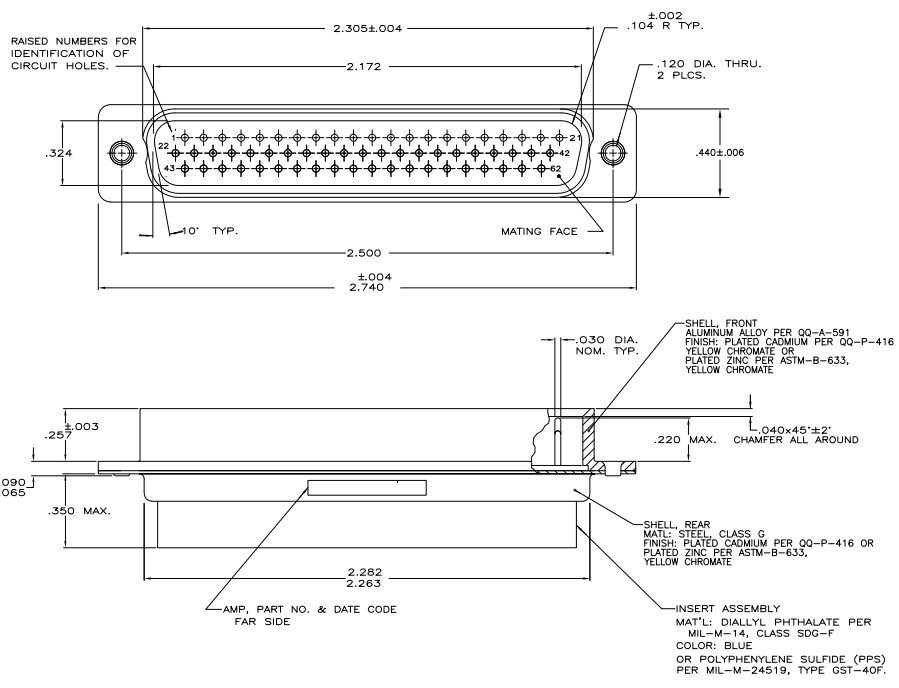

1. THIS PLUG WILL MATE WITH ANY 62 POSN. SIZE 4 RECEPTACLE IN AMPLIMITE SERIES.
2. MAXIMUM WIRE INSULATION TO BE USED WITH THIS PLUG IS .054 DIA.
3. SST RETENTION CLIPS ARE INCLUDED IN INSERTS.
4. THIS PLUG IS DESIGNED TO CONFORM TO THE LATEST ISSUE OF MIL-C-24308.
5. CONNECTOR SUPPLIED WITHOUT CONTACTS SHOWN FOR ILLUSTRATION ONLY.
6. THIS PLUG WILL ACCEPT SIZE 22 DM PIN CONTACT M39029/58-22-22D OR ANY AMP SIZE 22 DF PIN CONTACT.

▲ UL/CSA DESIGNATION STAMPED IN THIS AREA

PRELIMINARY NOT RELEASED FOR PRODUCTION	ZINC	AS SHOWN	213118-2
	CADMIUM	AS SHOWN	213118-1
	SHELL FINISH	DESCRIPTION	PART NUMBER

THIS DRAWING IS A CONTROLLED DOCUMENT.		DATE: 10-17-83	BY: [Signature]	FOR: [Signature]
DESIGNER: [Signature]	ENGINEER: [Signature]	DATE: 10-28-83	BY: [Signature]	FOR: [Signature]
PROJECT: [Signature]	OPERATION SPEC: [Signature]	DATE: [Signature]	BY: [Signature]	FOR: [Signature]
SEE CALLOUT	SEE CALLOUT	DATE: [Signature]	BY: [Signature]	FOR: [Signature]
CUSTOMER DRAWING		DATE: 10-28-83	BY: [Signature]	FOR: [Signature]