

REVISONS		DATE	BY
4899	DF	DO	PK
1	L	REV PER ECD 08-020669	30/09/08

- THIS PLUG WILL MATE WITH ANY SIZE 4, 62 POSN. RECEPTACLE IN AMPLIMITE SERIES.
 - OVERALL DIMENSIONS DO NOT INCLUDE RAISED CAVITY IDENTIFICATION.
 - BE-CU RETENTION CLIPS ARE INCLUDED AND INSTALLED WITH TINES POINTING TOWARDS MATING FACE.
 - CONNECTOR SUPPLIED WITHOUT CONTACTS. SHOWN FOR ILLUSTRATION ONLY.
 - MARKING ON FAR SIDE REFERS TO WIDE SIDE OF KEYSTONE. NEAR SIDE REFERS TO NARROW SIDE OF KEYSTONE.
- 100% INSPECTION REQUIRED PER BOEING 1B01:
- A. VISUAL
 - B. DWV
 - C. IR
- CUSTOMER REQUIRES SINGLE LOT DATE CODE.
- SPECIAL REQUIREMENTS:
- A. TEST TWO CONNECTORS PER LOT FOR COMPLIANCE TO GROMMET PEEL STRENGTH REQUIREMENTS.
 - B. TEST ALL CIRCUIT CAVITIES FOR MISALIGNMENT OR EXCESSIVE ADHESIVE.

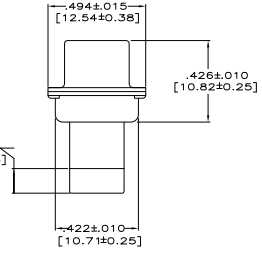
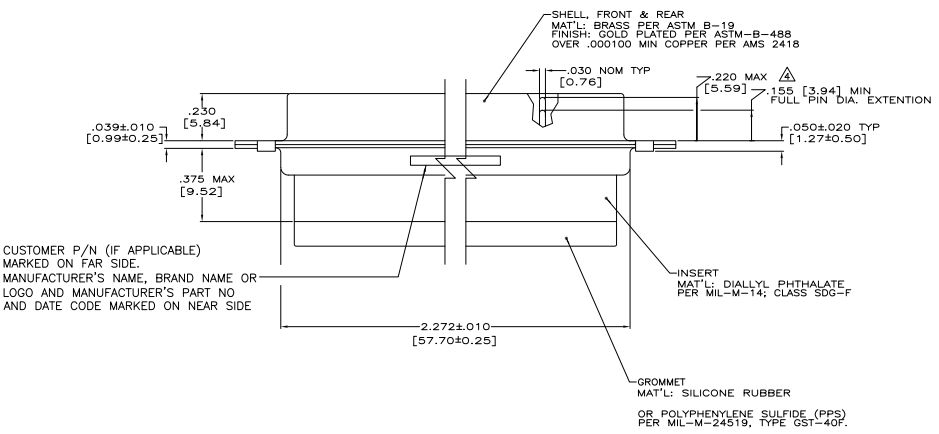
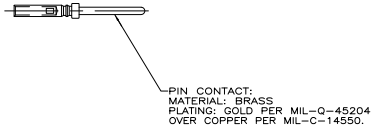
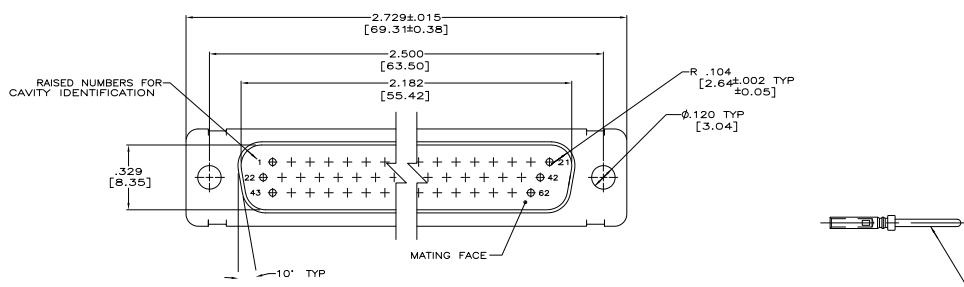

PIN CONTACTS INCLUDED IN KIT	REMARKS	CUSTOMER PART NO.	PART NO.
△	1B01-034PHW	1-211676-1	
△	B010648-0007	211676-7	
△	2A065-016V-001	211676-4	
△	1B01-034	211676-2	
△		211676-1	

THIS DRAWING IS A CONTROLLED DOCUMENT. CONTROLLED BY: J. THOMAS DATE: 11-20-07

DESIGNED BY: J. FENNEY DATE: 11-20-07

CHECKED BY: J. FENNEY DATE: 11-20-07

APPROVED BY: J. FENNEY DATE: 11-20-07

DATE OF ISSUE: 11-20-07

ISSUE NO: 1

REVISED TO: 100779 (G)=211676

CUSTOMER DRAWING

YTSO Electronics Corporation
 Harrisburg, PA 17105-2608

PLUG ASSY, AMPLIMITE, 62 POSN.,
 SIZE 4, SERIES 90, NON-MAGNETIC
 WITH GROMMET

REVISED TO: 100779 (G)=211676

DATE OF ISSUE: 11-20-07

ISSUE NO: 1

REVISED TO: 100779 (G)=211676