

REVISIONS			
REV	DATE	BY	APP
DF	DO	J	PK

1. THIS RECEPTACLE WILL MATE WITH ANY SIZE 4, 62 POSN. PLUG IN AMPLIMITE SERIES.
 2. CONNECTOR SUPPLIED WITHOUT CONTACTS; SHOWN FOR ILLUSTRATION ONLY.
 3. BE-CU RETENTION CLIPS ARE INCLUDED IN INSERT AND INSTALLED WITH TINES POINTING TOWARDS MATING FACE.
 4. OVERALL DIMENSIONS DO NOT INCLUDE RAISED CAVITY IDENTIFICATION.
- △ MARKING FAR SIDE REFERS TO WIDE SIDE OF KEYSTONE. NEAR SIDE REFERS TO NARROW SIDE OF KEYSTONE
 △ 100% INSPECTION REQUIRED PER BOEING 1801:
 A. VISUAL
 B. DWV
 C. IR
 △ CUSTOMER REQUIRES SINGLE LOT DATE CODE.
 △ SPECIAL REQUIREMENTS:
 A. TEST TWO CONNECTORS PER LOT FOR COMPLIANCE TO GROMMET PEEL STRENGTH REQUIREMENTS.
 B. TEST ALL CIRCUIT CAVITIES FOR MISALIGNMENT OR EXCESSIVE ADHESIVE.

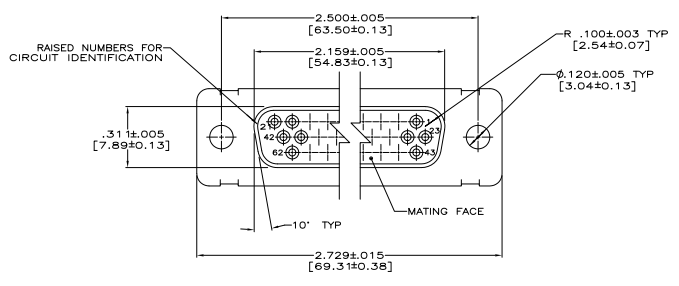

△ FOR (-2, -4 & -7) MARK MFG'S NAME, BRAND OR LOGO AND DATE CODE FAR SIDE. CUSTOMER P/N MARKED NEAR SIDE

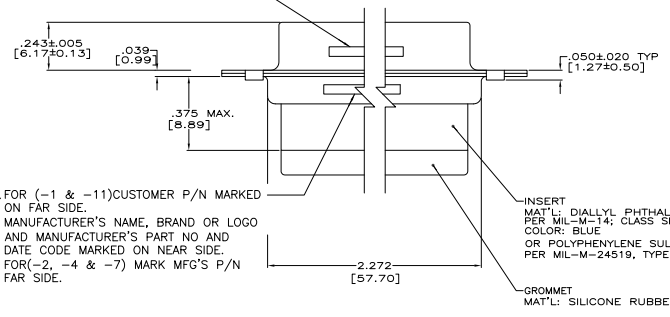

△ FOR (-1 & -11) CUSTOMER P/N MARKED ON FAR SIDE. MANUFACTURER'S NAME, BRAND OR LOGO AND MANUFACTURER'S PART NO AND DATE CODE MARKED ON NEAR SIDE. FOR (-2, -4 & -7) MARK MFG'S P/N FAR SIDE.

INSERT MAT'L: DIALLYL PHTHALATE PER MIL-M-14; CLASS 50G-F COLOR: BLUE OR POLYPHENYLENE SULFIDE (PPS) PER MIL-M-24519, TYPE GST-40F
 GROMMET MAT'L: SILICONE RUBBER

SHELL, FRONT & REAR MAT'L: BRASS PER ASTM B-19 FINISH: GOLD PLATED PER ASTM-B-488 OVER 0.000100 MIN COPPER PER AMS 2418

ALTERNATE CLINCH VIEW -4 ONLY

REV	DATE	BY	APP	DESCRIPTION
1				1B01-02BRHW 1-211670-1
2				B010648-0008 211670-7
3				2A065-022V-001 211670-4
4				1B01-02B 211670-2
5				1B01-02B 211670-1

REMARKS CUSTOMER PART NO. PART NO.

THIS DRAWING IS A CONTROLLED DOCUMENT

DESIGNED BY: J. THOMAS
 CHECKED BY: GILMAN
 DRAWN BY: J. ENDEY
 DATE: 10/10/00
 REV: 1
 SEE CALLOUTS
 SEE CALLOUTS

TYSO Electronics Corporation
 Harrisburg, PA 17105-2608
 RCPT. ASSY., AMPLIMITE, 62 POSN., SIZE 4, SERIES 90, NON-MAGNETIC WITH GROMMET
 SIZE: ONE ONLY DRAWING NO: A100779G=211670
 CUSTOMER DRAWING
 SHEET 4:1 OF 1