

REVISONS	
REV	DATE
1	17OCT08
2	
3	
4	
5	
6	
7	
8	

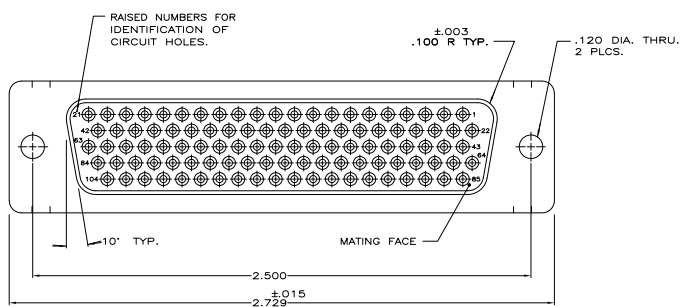

1. THIS RECEPTACLE WILL MATE WITH ANY SIZE 6,104 POSN. PLUG IN AMPLUMITE SERIES.
 2. CONNECTOR SUPPLIED WITHOUT CONTACTS; SHOWN FOR ILLUSTRATION ONLY.
 3. BE-CU RETENTION CLIPS ARE INCLUDED IN INSERTS AND INSTALLED WITH TINES POINTING TOWARDS MATING FACE.
 4. OVERALL DIMENSIONS DO NOT INCLUDE RAISED CAVITY IDENTIFICATION
 5. MARKING FAR SIDE REFERS TO WIDE SIDE OF KEYSTONE. NEAR SIDE REFERS TO NARROW SIDE OF KEYSTONE.
- △ 100% INSPECTION REQUIRED PER BOEING 1801:
- A. VISUAL
 - B. DWV
 - C. IR
7. CUSTOMER REQUIRES SINGLE LOT DATE CODE.

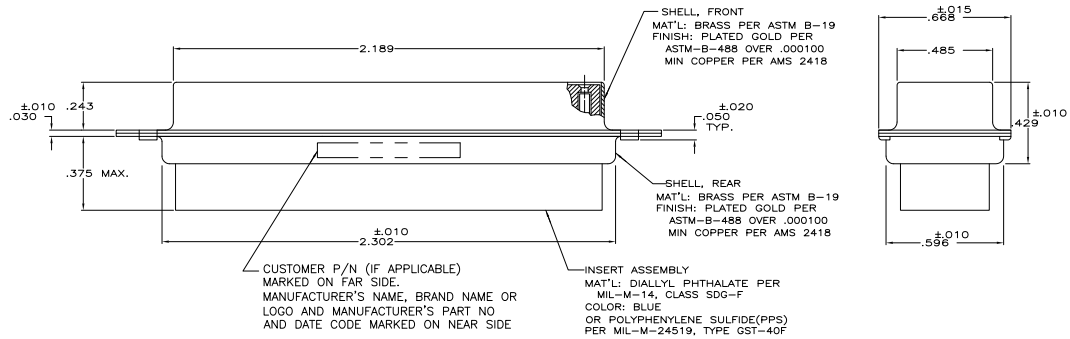

△	1801-006RHW	1-211648-1
△	1801-006	211648-1
REMARKS	CUSTOMER PART NUMBER	PART NO.

THIS DRAWING IS A CONTROLLED DOCUMENT.		DESIGNED BY	DATE
DRAWN BY		DATE	
CHECKED BY		DATE	
APPROVED BY		DATE	
MATERIAL		DATE	
SPECIFICATIONS		DATE	
REVISIONS		DATE	
CUSTOMER DRAWING		DATE	

RECEPTACLE ASSY, AMPLUMITE
 104 POSN, SIZE 4, SERIES 90
 NON-MAGNETIC

SIZE: ONE ONLY DRAWING NO: A100779G=211648

REWORKED TO: —

DATE: NTS