

REV	DATE	DESCRIPTION	BY	CHK	APP
DF					
F		REVISED PER ECO-09-012541			

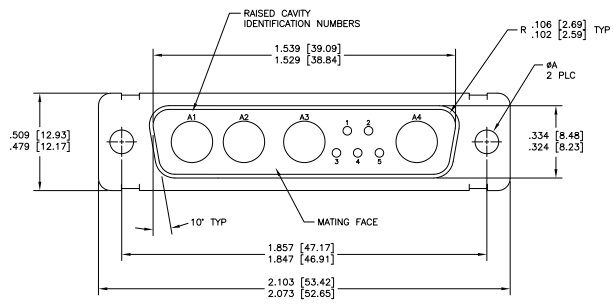

- THIS CONNECTOR ASSEMBLY IS SUPPLIED WITH SIZE 20 METAL CONTACT RETENTION CLIPS INSTALLED IN THE INSERT ASSEMBLY.
- THIS CONNECTOR ASSEMBLY MATES WITH ANY 9CA, SIZE 3 RECEPTACLE CONNECTOR IN THE AMPLIMITE SERIES.
- MARK WITH .047 [1.19]-.062 [1.57] HIGH CHARACTERS. FAR SIDE REFERS TO THE WIDE SIDE OF THE KEYSTONE. FAR SIDE MARKINGS MAY BE SPLIT BETWEEN FRONT AND REAR SHELLS.
- PART NUMBER FOR ORDERING.
- THIS CONNECTOR ASSEMBLY IS DESIGNED TO ACCEPT SIZE 20 CRIMP TYPE PIN CONTACTS IN POSITIONS 1 THRU 5 (NOT SUPPLIED) AND SIZE 8 PIN CONTACTS IN POSITIONS A1 THRU A4 (NOT SUPPLIED).
- MATERIAL: STEEL PER ASTM-A-109 OR EQUIVALENT.
- MATERIAL: BRASS ALLOY PER ASTM-B-36.
- FINISH: GOLD PER MIL-G-45204 TYPE II, GRADE C, CLASS 1 OVER COPPER PER MIL-C-14550, CLASS IV.
- FINISH: CADMIUM PER QQ-P-416, TYPE II, CLASS 2 OVER COPPER PER MIL-C-14550, CLASS IV.
- FINISH: TIN PER ASTM-B-545 .000200 [0.0051] MIN THK OVER COPPER PER AMS2418 .000100 [0.0025]-.000200 [0.0051] THK.
- GROUNDING INDENTS FOR 212498-4 & 5-212498-4 ONLY.
- DIMENSIONS AND TOLERANCES PER ANSI Y14.5M-1982.
- THIS DRAWING SHALL BE INTERPRETED IN ACCORDANCE WITH APPLICABLE STANDARDS LISTED IN MIL-STD-100.
- FINISH: TIN PER ASTM-B-545 .000200 [0.0051] MIN THK OVER COPPER PER AMS2418 .000100 [0.0025]-.000200 [0.0051] THK.
- FINISH: ZINC PLATE PER ASTM-B-633 .000200-.000400 THK WITH SUPPLEMENTARY CHROMATE (Cr3+).

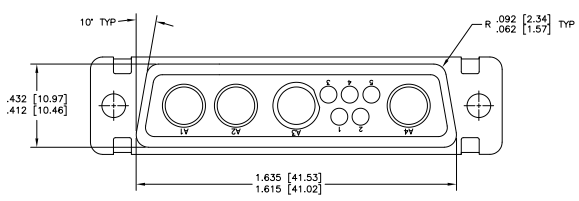
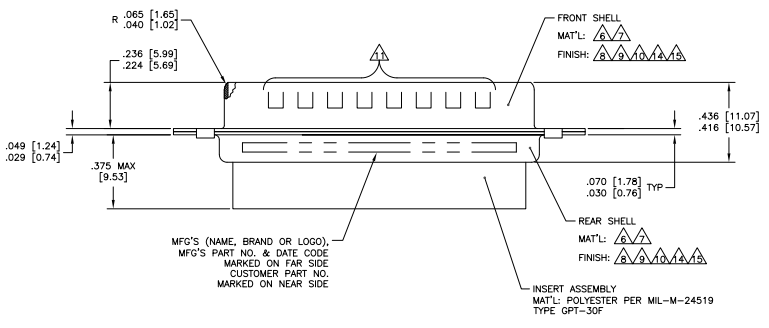

[Symbol]	.120 [3.05]	T5935-0103-007	212498-6	212498-6
[Symbol]	.120 [3.05]	-	5-212498-4	5-212498-4
[Symbol]	.120 [3.05]	-	5-212498-1	5-212498-1
[Symbol]	.120 [3.05]	-	212498-4	212498-4
[Symbol]	.154 [3.92]	311P405-115-B-15	212498-3	212498-3
[Symbol]	.120 [3.05]	311P405-115-B-12	212498-2	212498-2
[Symbol]	.120 [3.05]	-	212498-1	212498-1
REMARKS	#A	CUSTOMER P/N ON CONNECTOR	MFG'S P/N ON CONNECTOR	PART NO.

THIS DRAWING IS A CONTROLLED DOCUMENT.

DESIGNED BY	REVISED BY	DATE	REVISION
APPROVED BY	DATE	REVISION	

AMPLIMITE PLUG ASSEMBLY, CRIMP
 SNAP, DDMX MILY 9CA
 SERIES 100, SHELL SIZE 3

SIZE: 4-1
 SHEET: 1 of 1
 DATE: 00779
 CUSTOMER DRAWING: 212498