

4

3

2

1

THIS DRAWING IS UNPUBLISHED.		RELEASED FOR PUBLICATION		REV. 1	
(C) COPYRIGHT IS BY AMP INCORPORATED. ALL RIGHTS RESERVED.		DF	DO	DATE	BY
		A		ADD -2 PER 0630-0476-00	11-00 CT DM

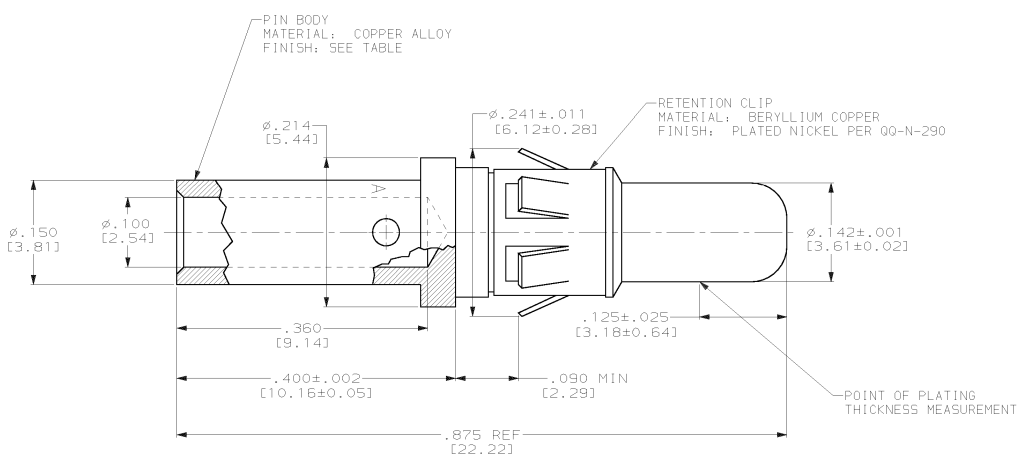

1. THIS PART CONFORMS TO REQUIREMENTS FOR DANIELS CRIMP TOOL NO. M300-B7, WITH DANIELS POSITIONER PART NO. SP689, STRIP LENGTH .375, SETTING 1.
 2. WIRE BARREL WILL ACCEPT #12-#14 AWG WIRE.
 3. MATES WITH 212008-1.
- FINISH: PLATED GOLD .000050 [0.00127] MIN THK PER MIL-G-45204 OVER NICKEL .000050 [0.00127] MIN THK PER 00-N-290.
 FINISH: PLATED GOLD .000030 [0.00076] MIN THK PER MIL-G-45204 OVER NICKEL .000050 [0.00127] MIN THK PER 00-N-290.

PRELIMINARY NOT RELEASED FOR PRODUCTION			1218483-2
			1218483-1
		FINISH	PART NUMBER
THIS DRAWING IS A CONTROLLED DOCUMENT.		AMP	AMP Incorporated Harrisburg, PA 17105-3608
DIMENSIONS: INCHES (mm) DIMENSIONS: DECIMALS (mm) DIMENSIONS: ANGLES	DWG: C. C. THOMAS 11/17/99 DES: J. MILLER 11-18-99 DATE: J. MILLER 11-18-99 PROJECT SPEC: - APPLICATION SPEC: - MATERIAL: - FINISH: - WEIGHT: - SEE CALLOUTS: SEE CALLOUTS	ASSEMBLY, PIN CONTACT, POWER VIII1, #12-14 AWG, BLINDMATE SIZE: A2 CASE CODE: 00779 DRAWING NO: 1218483 RESTRICTED TO: - CUSTOMER DRAWING	SCALE: 10:1 SHEET: 1 OF 1 REV: A