

4

3

2

1

THIS DRAWING IS UNPUBLISHED. RELEASED FOR PUBLICATION. ALL RIGHTS RESERVED.

LOC	DIST	REVISIONS				
DF	DO	P	LR	DATE	BY	APP'D
		J1		REVISED PER ECO-11-005030	11MAR11	RK HMR

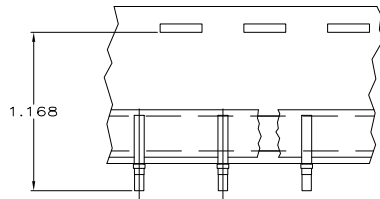
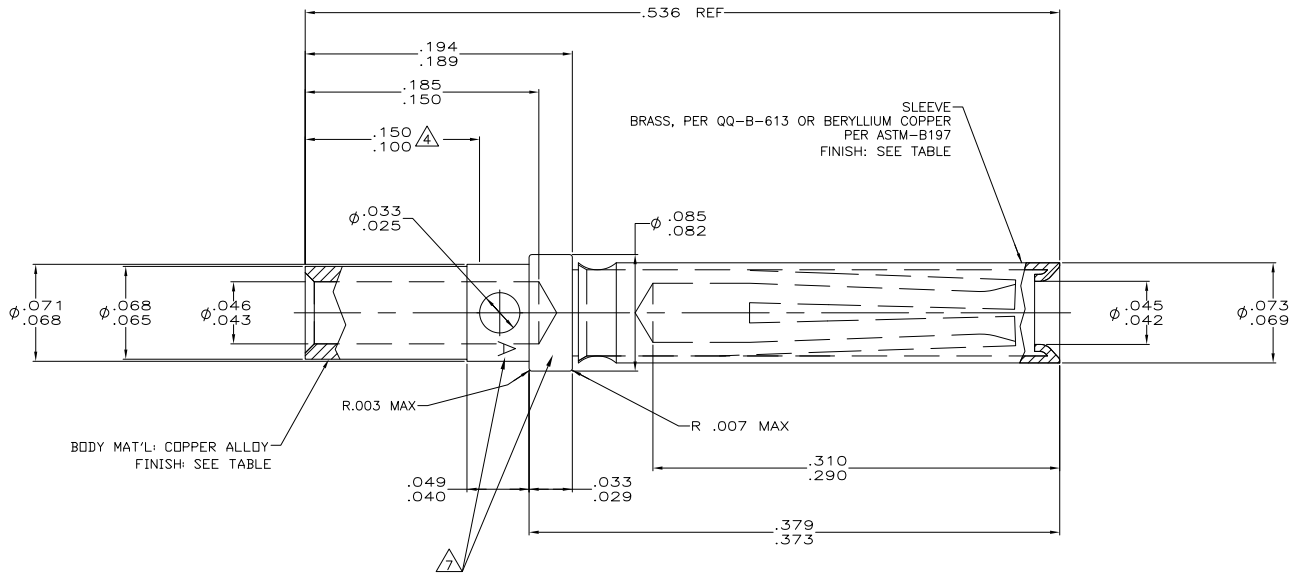

- CONTACTS MUST MEET ALL REQUIREMENTS OF GSFC-S-311-P-4/08 AND AS39029.
- ALL DIAMETERS ARE CONCENTRIC WITH EACH OTHER WITHIN .004 T.I.R.
- ALL SURFACES HAVE  $\sqrt{63}$  OR BETTER FINISH. POINT OF PLATING THICKNESS MEASUREMENT.
- SLEEVE MAY BE CRIMPED OR DIMPLED TO BODY.
- MINIMUM SEPERATION FORCE OF 7 OZ USING A .039 PIN AND 4 OZ MAX ENGAGEMENT FORCE USING A .041 PIN.
- OPTIONAL LOCATION FOR STAMPED LETTER 'A'
- PLATING: GOLD PER ASTM-B-488 (TYPEII) OVER COPPER PER MIL-C-14550, CLASS 4.
- PLATING: GOLD PER ASTM-B-488 (TYPEII) OVER NICKEL PER QQ-N-290.

OBSOLETE	9	AS SHOWN	206793-4
	8	SAME AS -1 EXCEPT 6	206793-3
	8	SAME AS -1 EXCEPT TAPE MOUNTED 5,000 CONTACTS PER REEL	206793-2
	8	AS SHOWN	206793-1
	FINISH	DESCRIPTION	PART NO

DIMENSIONS:		DRAWN:		DATE:		TE Connectivity	
INCHES		C.C. THOMAS		11-20-02		TE Connectivity	
OTHER DIMENSIONS:		D. MILLER		11-20-02		SOCKET CONTACT ASSY, SIZE 20, AMPLIMITE	
MATERIAL:		D. MILLER		11-20-02		APPLICATION SPEC:	
SEE CALLOUT		FINISH:		WEIGHT:		SIZE: CAGE CODE: DRAWING NO:	
						A2 00779 C-206793	
						CUSTOMER DRAWING	
						SCALE: 20:1 SHEET: 1 of 1 REV: J1	

1471-9 (3/11)

206793

B

A