

This document is the property of Amphenol Corporation and is delivered on the express condition that it is not to be disclosed, reproduced or used, in whole or in part, for manufacture or sale by anyone other than Amphenol Corporation without its prior consent, and that no right is granted to disclose or to use any information in this document.

Customer drawing

REVISIONS				
SYM	ECH	DESCRIPTION	DATE	APPROVED
E			02/03/08	

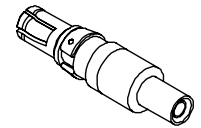
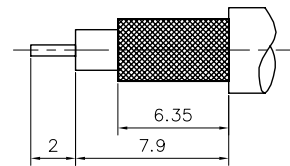
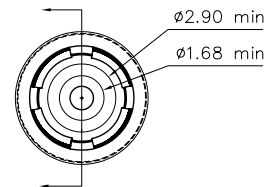
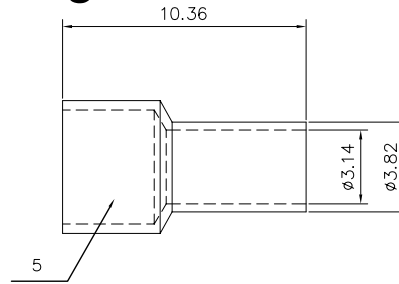
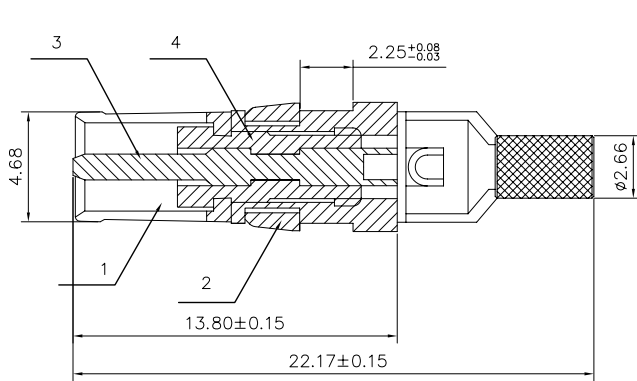

Trim cable

Notes:

- Commercial number is L17DM537421
- ELECTRICAL: Voltage rating 250 V Rms to 50 Hz
Current rating 3A
Withstanding Voltage >1000 V Rms
Insulation resistance >1000 M Ohms
Contact resistance: center contact 5.0 mOhms
outer contact 3.0 mOhms.
- Cable RG: 179 B/U
- Ferrule crimp: 3.25/plats
- CLIMATIC: Temperature range -55 °C up to 125°C
- MARKING: Amphenol...(Series No.)
Manufacturing date
Commercial reference

Sequence	Material	Remark
5	brass	gold over 1.25 min nickel
4	ferrule	Color white
3	Phosphor bronze	0.75um min gold over 1.25 min nickel
2	thermoplastic	Color black
1	brass	gold over 1.25 min nickel



UNLESS OTHERWISE SPECIFIED	APPROVAL	DATE	Amphenol®
TOLERANCES U.S. METRIC .X +/- .20 .XX +/- .10 .XXX +/- .05 FRACTIONS +/- ANGLES +/- 2° FOR MATERIALS AND FINISHES SEE NOTES REMOVE SHARP EDGES DIMENSIONS U.S. INCHES METRIC MM	DRAWN Shuang LA 02/03/08 CHECKED tk.wang 02/03/08	DRAWING FILE : ANGLE OF PROJECTION	
SIZE A4 SCALE NONE	DRAWING NO. C L17DM53742-1	SHEET 1 OF 1	REV. E