

used for: D-SUB

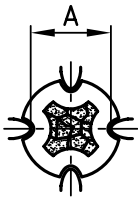

(c)

Selector settings	Crimp height A
7 for AWG 20	0.87 - 0.98
6 for AWG 22	0.77 - 0.88
5 for AWG 24	0.67 - 0.78

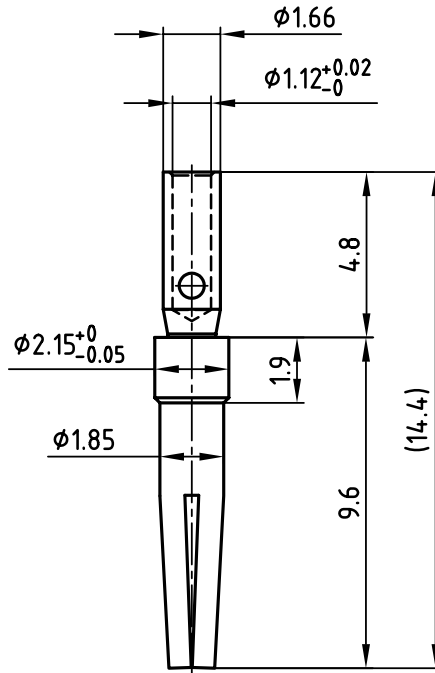

(b) STRIPPING DIMENSIONS

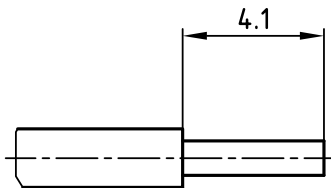

Notes:

- Material: brass
- Finish: hard-gold-plated in the contact area
- Temperature range: -55°C to +125°C
- Rated current: 7.5A
- Contact resistance: <math>\leq 10\text{m}\Omega</math>
- (b) Crimping: use crimp tool 360X10329X with tool insert 360X20069X selector settings: 7 for AWG 20, 6 for AWG 22, 5 for AWG 24

APPROVAL # FREIGABE # DEBLOCAGE # AUTORIZACION # APPROVAL

CUSTOMER APPROVAL DATE:

NAME: TITLE:

COMPANY NAME:

APPROVAL # FREIGABE # DEBLOCAGE # AUTORIZACION # APPROVAL



THIS DRAWING MAY NOT BE COPIED OR REPRODUCED IN ANY WAY, AND MAY NOT BE PASSED ON TO A THIRD PARTY WITHOUT WRITTEN PERMISSION. OWNERSHIP AND COPYRIGHT OF CONEC GmbH DO NOT ALTER CAD DRAWING BY HAND

tolerance		dim. in mm	
2004	date	name	
drawn	21.05.	Lehmenkühler	
appd.	21.05.	Kühle	
norm			
d-old			
1 x c	Ä 2197	01.04.2005	Lehmen.
2 x b	Ä 2177	11.03.2005	Lehmen.
rev.	description	date	name



scale:	5:1	
material:	SEE NOTES	
title:	CRIMP SOCKET CONTACT screw machined version accepts cable AWG 24-20	
dwg no:	AutoCAD 2004	DIN-A
	16K2A929	4
part no:	162A18709X	
		sh: 1/1

4

3

2

1