

used for: D-SUB HD

(b) STRIPPING DIMENSIONS

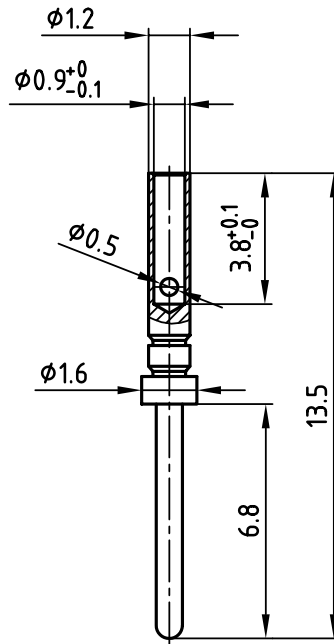
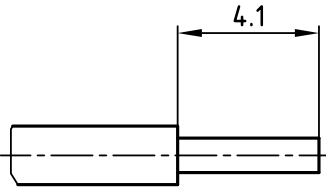

(b) NOTES:

1. CONTACTS: BRASS
2. PLATING: 8µin HARD GOLD OVER min. 50µin NICKEL
3. CRIMPING: USE CRIMP TOOL 360X10329X WITH TOOL INSERT 360X10629X
SELECTOR SETTINGS: 4 for AWG 22
3 for AWG 24
2 for AWG 26
1 for AWG 28

Directive 2002/95/EC
"RoHS"
Compliant

THIS DRAWING MAY NOT BE COPIED OR REPRODUCED IN ANY WAY, AND MAY NOT BE PASSED ON TO A THIRD PARTY WITHOUT WRITTEN PERMISSION.
OWNERSHIP AND COPYRIGHT OF CONEC GmbH
DO NOT ALTER CAD DRAWING BY HAND

tolerance ISO 2768-m					
2001	date	name			
drawn	12.03.	Parei			
appd.	12.03.	E. Mickenbecker			
norm					
d-old					
2 x b	Ä 2647	11.01.2007	Lehmen		
a	Origin				
rev.	description	date	name		

scale: 5:1
material: SEE NOTES

title:
HD CRIMP PLUG CONTACT

dwg no: AutoCAD 2000 DIN-A
16K1A152A 4
sh: 1/1
part no: 161A18009X

4

3

2

1