

DRAWING MADE IN AMERICAN PROJECTION

1913 BY AMP INCORPORATED. ALL RIGHTS RESERVED. AMP PRODUCTS COVERED BY PATENTS AND/OR PATENTS PENDING.

Unpublished copy not to be reproduced without written permission of AMP Inc.

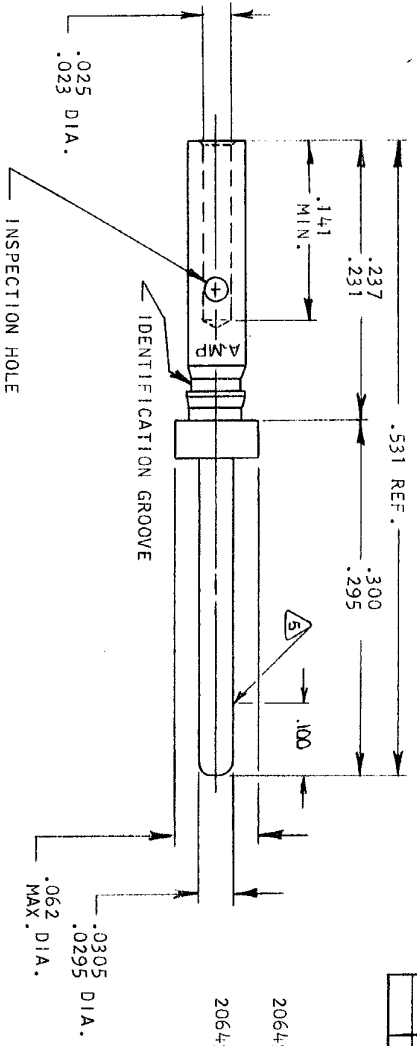

1. WIRE BARREL WILL ACCEPT # 26-28 AWG WIRE.
  2. CRIMPING TOOL - USE MS 3198-1 WITH APPLICABLE POSITIONER.
  3. CONTACT CONFORMS TO MIL-C-24308, SIZE 22 EXCEPT WIRE BARREL.
  4. INSERTION / EXTRACTION TOOL - AMP P/N 91054-1
- POINT OF PLATING THICKNESS MEASUREMENT.

WHEN ORDERING CONTACT ON TAPE, ORDER BY THE TAPENUMBER PLUS THE PACKAGING CODE AS FOLLOWS:

1. FOR USE WITH AMP TAPETRONIC, PNEUMATIC TOOL -
  - A. 1000 PARTS TO A BOX ADD PACKAGING CODE: 1MBOX
2. FOR USE WITH 4/8 INDENT STRIPPER CRIMPER -
  - A. 1000 PARTS TO A REEL ADD PACKAGING CODE: 1MREEL
  - B. 5000 PARTS TO A REEL ADD PACKAGING CODE: 5MREEL

REVISIONS				
ZONE	LTR	DESCRIPTION	DATE	APPROVED
0		RELEASED WAS 5064-45 NO.	10/5/73	gms
A		REV PER ECN C-669	11-29-73	gms
B		CHANGED MAT'L ECN E-779	12/20/76	gms
C		REV PER ECN J-985	1-28-83	gms

- 206495 - 3 1. AS SHOWN.  
2. PLATING : GOLD PER MIL-G-45204 OVER COPPER
- 206495 - 4 1. SAME AS -3 EXCEPT:  
2. CONTACTS ON TAPE.

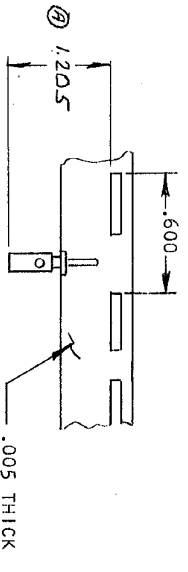

UNLESS OTHERWISE SPECIFIED DIMENSIONS ARE IN INCHES. TOLERANCES ON: ANGLES ± #		CONTRACT NO.	
MATERIAL: COPPER ALLOY PER QQ-C-530		DR. 10/5/73	
DESIGN APPD: [Signature]		DATE: 10/11/73	
OTHER APPD:		SCALE: 10:1	
NAME: AMP CONTACT, PIN SIZE 22D		AMP INCORPORATED HARRISBURG, PENNSYLVANIA	
SIZE: B	CODE IDENT NO.: 00779	NUMBER: 206495	SHEET: 1 OF 1

AMP 1470-1 REV (7/68) 4 3 2

CUSTOMER DRAWING