

VS-09-SET-EMV

Order No.: 1689158



<http://eshop.phoenixcontact.de/phoenix/treeViewClick.do?UID=1689158>

D-SUB connector set, shell size 1, IP67 protection, with shrouds



Commercial data	
EAN	4017918890568
Pack	1 pcs.
Customs tariff	85366990
Weight/Piece	0.0781 KG
Catalog page information	Page 264 (PC-2009)

Product notes

WEEE/RoHS-compliant since:
06/02/2006



<http://www.download.phoenixcontact.com>
Please note that the data given here has been taken from the online catalog. For comprehensive information and data, please refer to the user documentation. The General Terms and Conditions of Use apply to Internet downloads.

Technical data

Mechanical characteristics	
Shielded	Yes
Insertion/withdrawal cycles	≥ 1000
External cable diameter	3 mm ... 9 mm
Cable exit	Angled

Color	gray
Ambient temperature (operation)	-40 °C ... 80 °C

Material data

Inflammability class acc. to UL 94	V0
Housing material	PA
Sealing material	Flat gasket: NBR; profile gasket: EPDM
Seal material	Flat gasket: NBR; profile gasket: EPDM
Cable seal material	CR/NBR
Degree of protection	IP67

Diagrams/Drawings

Dimensioned drawing

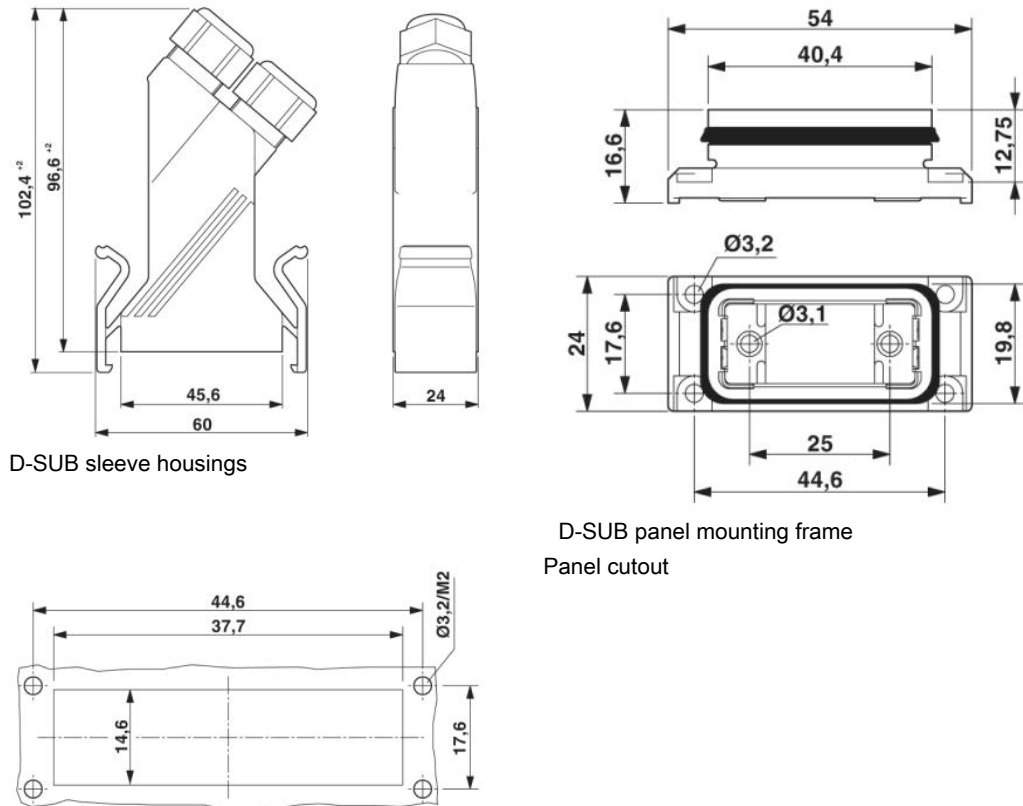

Address

PHOENIX CONTACT Inc., USA
586 Fulling Mill Road
Middletown, PA 17057, USA
Phone (800) 888-7388
Fax (717) 944-1625
<http://www.phoenixcon.com>



© 2010 Phoenix Contact
Technical modifications reserved;