

THIS DRAWING IS UNCLASSIFIED
 RELEASED FOR PUBLICATION
 BY AMP INCORPORATED. ALL RIGHTS RESERVED.

GEGENSTECKER/KONTAKT:
 MATED WITH: 745 493-2 745 494-5

REVISONS					
LOC	REV	DATE	DESCRIPTION	BY	APPD
A1	-				
	0	16.10.1995	ZEICHNUNG FREIGEgeben	FILLE	-
	01	15.11.1996	LÖTÖSE UND BLECHSCHRAUBE GEÄNDERT	FILLE	-
	A	30.01.1997	AUSFÜHRUNG 966 825-2 HINZU	FILLE	-

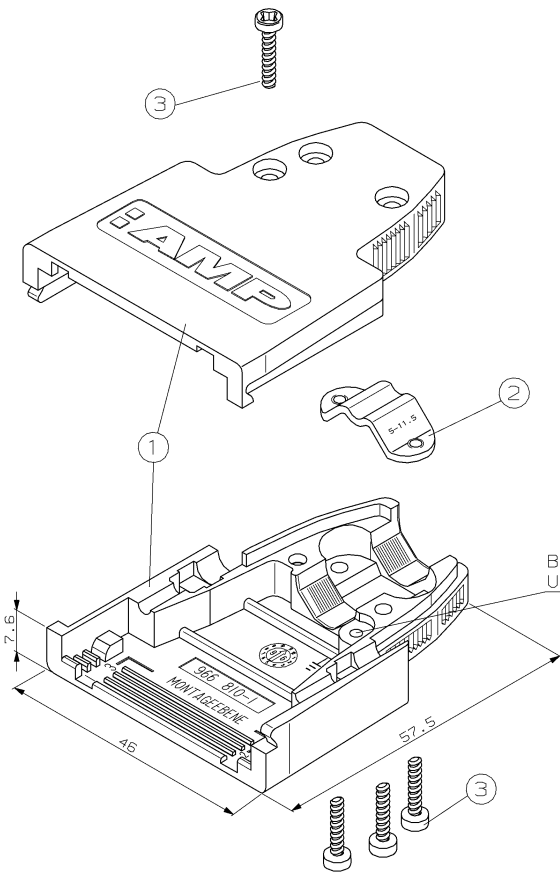

MÖGLICHE KABELDURCHMESSER:

\varnothing 3-5mm
 \varnothing 5-11.5mm } SIEHE PRÄGUNG AUF KABELSCHELLE

VERPACKUNGSEINHEIT:

TEILE IN PLASTIKBEUTEL VERPACKT
 10 PLASTIKBEUTEL IN FALTSCHACHEL

BOHRUNG FÜR BLECHSCHRAUBE DIN 7981 B2.2x4.5-Z1 (POZIDRIV)
 UND LÖTÖSE DIN41496 2x12 A1 (NICHT IM LIEFERUMFANG ENTHALTEN)

AMP ORDER NO. BESTELL-NR.	POS.	QTY. STK.	DESCRIPTION BENENNUNG	SURFACE OBERFLÄCHE COLOUR/FARBE	MATERIAL
966 825-2	3	4	TAPTITE-SCREW M2.5	ZINC PLATED	STEEL
	2	1	TAPTITE-SCHRAUBE M2.5	VERZINKT	STAHL
966 825-1	1	2	CABLE CLAMP KABELSCHELLE	TIN OVER COPPER VERZINNT A. KUPFER	STEEL STAHL
	2	1	COVER HALF SCHIRMKAPPENHALFTE	NICKEL PLATED -VERNICKELT	ALUMINIUM
966 825-1	3	4	TAPTITE-SCREW M2.5	ZINC PLATED	STEEL
	2	1	TAPTITE-SCHRAUBE M2.5	VERZINKT	STAHL
966 825-1	1	2	CABLE CLAMP KABELSCHELLE	TIN OVER COPPER VERZINNT A. KUPFER	STEEL STAHL
	2	1	COVER HALF SCHIRMKAPPENHALFTE	PLAIN BLANK	ALUMINIUM

DIMENSIONS:		DATE: 24-FEB-95 DRAWN BY: K. TILLE CHECKED BY: S. KRÄMER APPROVED BY: R. FELDMAYER PRODUCT SPEC: - APPLICATION SPEC: 114-18 120 WEIGHT: - MATERIAL: -	AMP AMP Deutschland GmbH D - 63225 Langen AMPLIMITE - SHIELDED COVER KIT (SIZE 2) AMPLIMITE - ABSCHIRMKAPPEN KIT (BAUGROSSE 2) SIZE: 144-18 120 CUSTOMER DRAWING: A2 00779 C-966825 RESTRICTED TO: -
-------------	--	--	--