

BOOT
SEE TABLE

AMP LOGO
SEE TABLE

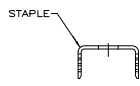

STAPLE

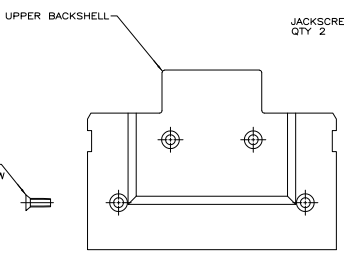

UPPER BACKSHELL

JACKSCREW
QTY 2

LOWER BACKSHELL

2-56
SELF-TAPPING SCREW
QTY = 4

68L

THREAD, SEE TABLE

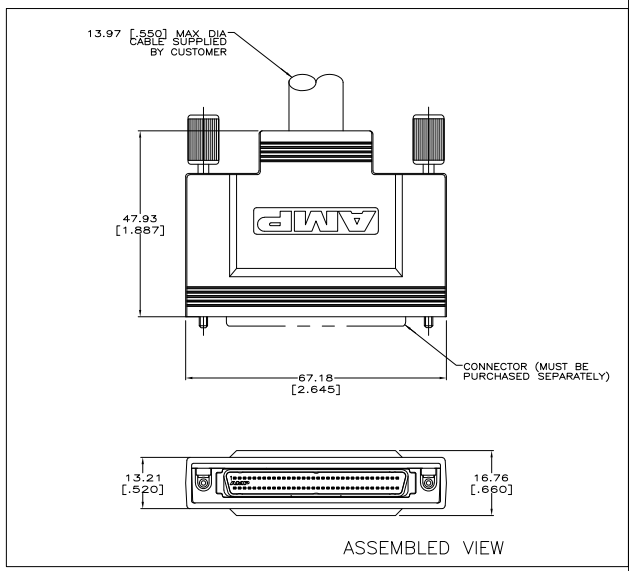

13.97 [550] MAX DIA
CABLE SUPPLIED
BY CUSTOMER

47.93
[1.887]

67.18
[2.645]

CONNECTOR (MUST BE
PURCHASED SEPARATELY)

13.21
[.520]

16.76
[.660]

ASSEMBLED VIEW

- ▲ BOOT MATERIAL: PVC, BLACK.
- ▲ BACKSHELL MATERIAL: ZINC PER ASTM B86.
- ▲ JACKSCREW MATERIAL: STAINLESS STEEL & PVC, BLACK.
- ▲ STAPLE MATERIAL: CARBON STEEL PER ASTM A109.
- ▲ SCREW MATERIAL: STAINLESS STEEL.
- ▲ STAPLE: 1.27µm [.000050] MIN BRIGHT TIN-LEAD OVER 1.27µm [.000050] MIN NICKEL.
- ▲ BULK PACKAGE.
- ▲ INDIVIDUAL PACKAGE.
- ▲ 1.27µm [.000050] MIN BRIGHT TIN OVER 1.27µm [.000050] MIN NICKEL.

SUPERSEDED BY 5750752-1	▲	YES	YES	2-56	▲	750752-6
SUPERSEDED BY 750752-1	▲	NO	YES	2-56	▲	750752-5
	▲	YES	YES	2-56	▲	750752-4
OBSOLETE	▲	NO	NO	2-56	▲	750752-3
OBSOLETE	▲	YES	YES	4-40	▲	750752-2
	▲	YES	YES	2-56	▲	750752-1

STAPLE FINISH	AMP LOGO	BOOT	JACKSCREW THREAD	PART NUMBER
▲	▲	▲	▲	▲

THIS DRAWING IS A CONTROLLED DOCUMENT		DATE: 4-17-81	BY: [Signature]	YTD Electronics Corporation Harrisburg, PA 17105-3008
DESIGNER: [Signature]	APPROVER: [Signature]	DATE: 4-17-81	BY: [Signature]	BACKSHELL KIT, UNASSEMBLED, 68 POSITION, .050 SERIES AMP/LIMIT
SIZE: A1	DATE CODE: 00779	DRAWING NO: G=750752	REVISED TO: [Signature]	
CUSTOMER DRAWING		SCALE: 2:1	SHEET: 1	TOTAL SHEETS: 1