

DESCRIPTION: QUICK RELEASE - DIE CAST

SPECIFICATION:

MATERIAL: ZINC ALLOY, ZAMAK Z0410

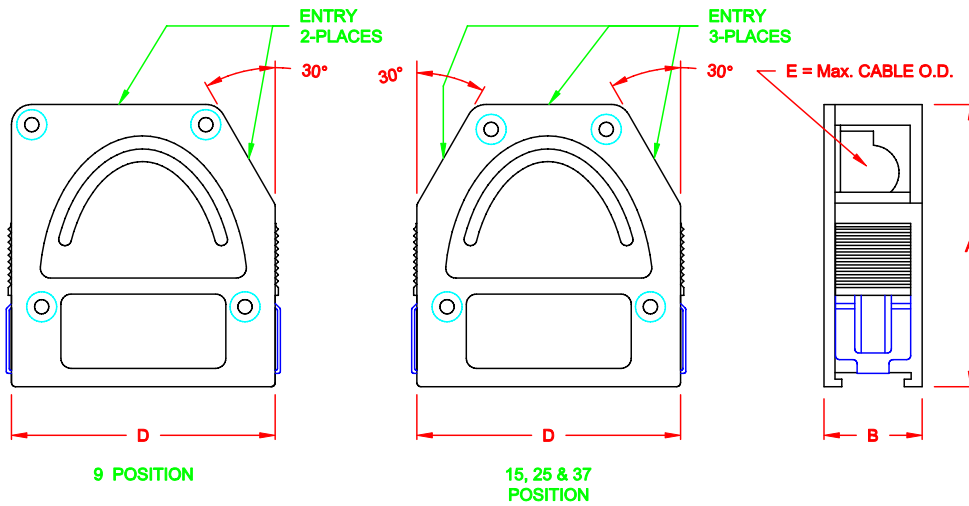

BACKSHELL KIT INCLUDES:

- (2) BACKSHELL HALVES
- (4) MOUNTING SCREWS
- (1) GROUNDING SCREW

 *** CABLE CLAMP ORDERED SEPARATELY ***
 *** SEE SHEET 2 ***

955-YYY-030R121

SERIES _____
 POSITIONS _____
 009 _____
 015 _____
 025 _____
 037 _____
 MATERIAL _____
 030 = DIE CAST _____
 RoHS COMPLIANT _____
 R = HIGH TEMP. PROCESS _____
 COLOR _____
 12 = METAL(IZED) _____
 PUT-UP _____
 1 = KIT _____

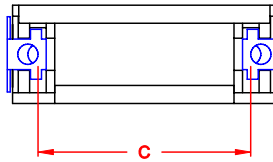

DIMENSIONS (IN.)					
No. OF PINS	A	B	C	D	E
09	1.740	0.606	0.984	1.299	0.354
15	1.740	0.606	1.312	1.626	0.394
25	1.740	0.606	1.852	2.165	0.433
37	1.740	0.606	2.500	2.815	0.433

DO NOT SCALE FROM DRAWING

RoHS COMPLIANT

	THESE DRAWINGS AND SPECIFICATIONS ARE THE PROPERTY OF NorComp AND SHALL NOT BE REPRODUCED, COPIED OR USED AS THE BASIS FOR THE MANUFACTURE OF SALE OF APPARATUS WITHOUT WRITTEN PERMISSION.		DRAWN: C. SMITH	DATE: 04-10-07
			CHECKED:	DATE:
NorComp		SCALE: 1:1	SHEET 1 OF 2	REV 1
		DWG NO. 955-YYY-030R121		

DESCRIPTION: QUICK RELEASE - CABLE CLAMPS OPTIONS

CABLE CLAMPS ORDERED SEPARATELY

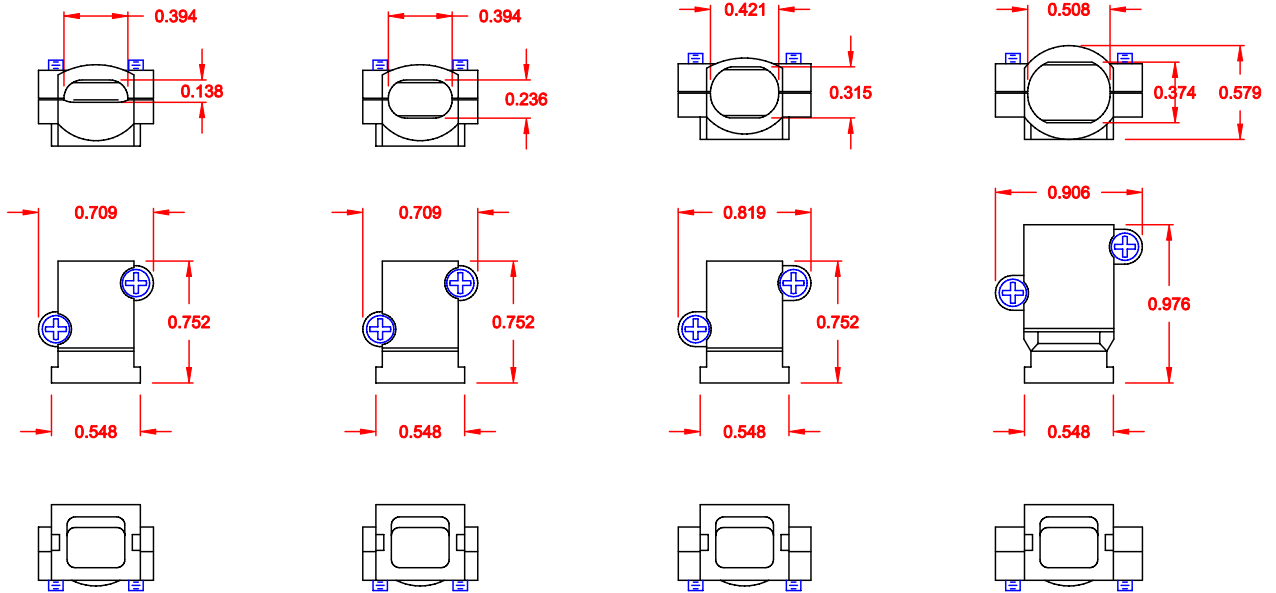

P/N 955-09-SR-4-7
CABLE RANGE = 0.157 - 0.276

P/N 955-15-SR-7-10
CABLE RANGE = 0.276 - 0.394

P/N 955-25-SR-9-12
CABLE RANGE = 0.354 - 0.472

P/N 955-37-SR-11-14
CABLE RANGE = 0.433 - 0.551

DO NOT SCALE FROM DRAWING

RoHS COMPLIANT

	THESE DRAWINGS AND SPECIFICATIONS ARE THE PROPERTY OF NorComp AND SHALL NOT BE REPRODUCED, COPIED OR USED AS THE BASIS FOR THE MANUFACTURE OF SALE OF APPARATUS WITHOUT WRITTEN PERMISSION.		DRAWN: C. SMITH	DATE: 04-10-07
			CHECKED:	DATE:
<h1 style="margin: 0;">NorComp</h1>		SCALE: 1:1	SHEET 2 OF 2	REV 1
		DWG NO. 955-YYY-030R121		