

DESCRIPTION: INTERNAL DIMENSIONS - DIE CAST

DIMENSIONS (IN.)

	9	15	25	37
A	0.738	1.076	1.623	2.250
B*	0.702	0.784	0.791	0.770
C			1.306	1.940
D			0.350	0.310
PCB	0.435	0.435	0.435	0.435

SEE NOTE 1. →

SEE NOTE 2. →

- NOTE:**
- "B" DIMENSION MEASURED FROM BACK SIDE OF CONNECTOR FLANGE
  - MIN. SAFE SPACING BETWEEN BACK SHELLS FOR PCB AND MOUNTED COMPONENTS
  - THESE DIMENSIONS ARE GOOD FOR THE NICKEL PLATED DIE CAST BACK SHELLS

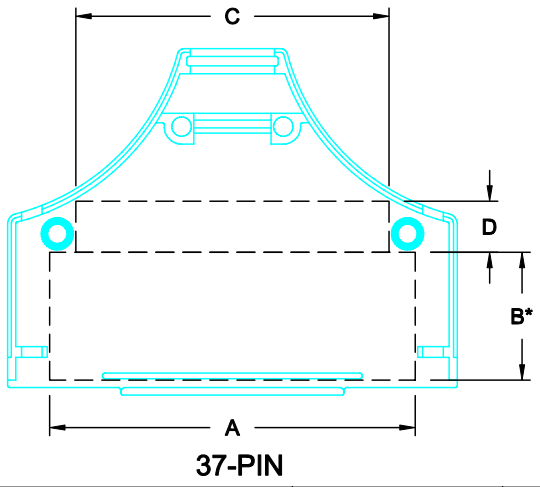
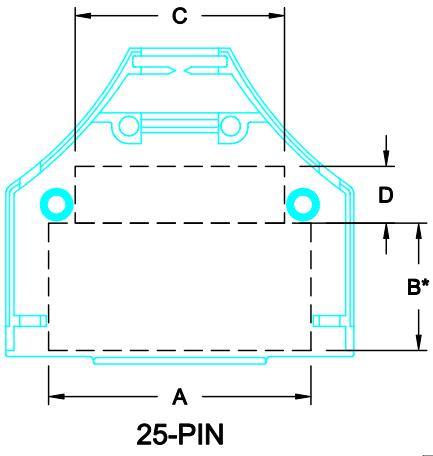
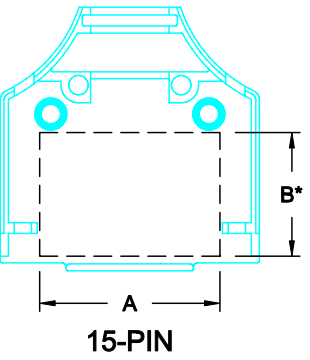
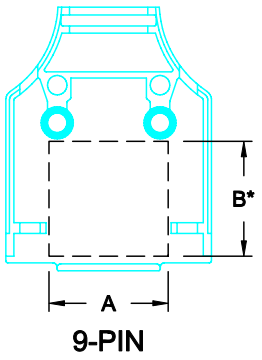

DIE CAST

DO NOT SCALE FROM DRAWING

RoHS COMPLIANT

	THESE DRAWINGS AND SPECIFICATIONS ARE THE PROPERTY OF NorComp AND SHALL NOT BE REPRODUCED, COPIED OR USED AS THE BASIS FOR THE MANUFACTURE OF SALE OF APPARATUS WITHOUT WRITTEN PERMISSION.		DRAWN: <b>C. SMITH</b>	DATE: <b>03-28-07</b>
			CHECKED:	DATE:
<h1>NorComp</h1>		SCALE: N.T.S.	SHEET 1 OF 1	REV 0
		DWG NO. <b>ID - 952 SERIES</b>		